

97055495
Rev. 03
2025-09



OPERATOR'S MANUAL C-17 PLUS / C-22 PLUS / C-28 PLUS



INDICE

1. FOREWORD	4
1.1. SYMBOLS USED	4
1.2. SYMBOLS ON THE DEVICE	4
1.3. STANDARDS AND REGULATIONS	5
1.4. CLASSIFICATION	5
1.5. INTENDED USE	5
1.5.1. IMPORTANT NOTES	5
1.6. GENERAL WARNINGS	6
1.7. RESIDUAL RISKS	6
1.8. INFORMATION ON MITIGATION OF RESIDUAL RISKS	7
1.9. ELECTROMAGNETIC SAFETY	8
1.10. NETWORK AND DATA SECURITY	9
2. CONTENTS OF THE PACKAGE	10
2.1. DIMENSIONS AND WEIGHT	10
2.2. DESCRIPTION OF THE CONTENT	11
2.3. PRODUCT HANDLING	12
2.4. CONDITIONS FOR STORAGE AND TRANSPORT	12
3. GENERAL DESCRIPTION - PRODUCT PRESENTATION	13
3.1. GENERAL CHARACTERISTICS	13
3.2. TECHNICAL CHARACTERISTICS	14
3.2.1. SUMMARY TABLE	14
3.3. SAFETY DEVICES	16
3.4. WATER SUPPLY CHARACTERISTICS	17
3.5. FRONT SIDE	18
3.6. REAR SIDE	19
3.7. DISPLAY ICONS	20
3.8. DESCRIPTION OF A STERILIZATION CYCLE	21
4. INSTALLATION	22
4.1. OVERALL DIMENSIONS	23
4.2. DIMENSIONS OF THE RECESSED INSTALLATION COMPARTMENT	24
4.3. GENERAL PRECAUTIONS FOR INSTALLATION	25
4.4. POWER SUPPLY	25
4.5. ELECTRICAL CONNECTIONS	25
4.6. DIRECT CONNECTION TO CENTRALIZED DRAINING POINT	26
5. FIRST START-UP	27
5.1. POWER ON	27
5.2. MAIN MENU	29
5.3. INTEGRATED DEMINERALISATION FILTER	30
5.3.1. SAFETY PRECAUTIONS	30
5.3.2. FIRST INSTALLATION OF THE DEMINERALISATION FILTER INSIDE THE TANK	31
5.3.3. PRECAUTIONS TO AVOID WATER STAGNATION	31
5.3.4. TECHNICAL SPECIFICATIONS OF THE DEMINERALISATION FILTER	32
5.4. MAINTENANCE OF THE INTEGRATED DEMINERALISATION FILTER	33
5.5. DISTILLED WATER FILLING	33
5.5.1. MANUAL FILLING	34
5.5.2. AUTOMATIC FILLING	34
6. CONFIGURATION	35
6.1. SETTINGS	35
6.1.1. LANGUAGE	36
6.1.2. DATE AND TIME	37
6.1.3. USB	38
6.1.4. VIDEO TUTORIAL	40
6.1.5. PRINTERS	41
6.1.6. WI-FI	43
6.1.7. ETHERNET	48
6.1.8. USERS	50
6.1.8.1. CREATING THE FIRST USER	51
6.1.8.2. CREATING THE USER (OPERATION AVAILABLE ONLY FOR ADMINISTRATOR USER)	53
6.1.8.3. USER MANAGEMENT (OPERATION AVAILABLE ONLY FOR ADMINISTRATOR USER)	55
6.1.8.4. ENABLING THE USER IDENTIFICATION AT THE START AND END OF THE CYCLE (FUNCTION ONLY AVAILABLE TO ADMINISTRATOR USER)	58
6.1.8.5. USER MANAGEMENT (NON-ADMINISTRATORS)	59
6.1.9. PREHEATING	60
6.1.10. UNITS OF MEASUREMENT	62
6.1.11. REMINDER	63
6.1.12. (AUTOMATIC) H2O FILLING	64
6.1.13. SCREEN	66
6.1.14. SERVICE	67
7. PREPARING THE MATERIAL	68
7.1. TREATING THE MATERIAL BEFORE STERILIZATION	68
7.2. LOAD ARRANGEMENT	69
7.3. POSITIONING AND USING THE TRAY HOLDER SUPPORT	71
8. STERILIZATION CYCLES	72

8.1.	DRYING MANAGEMENT	74
8.2.	DELAY START	76
8.3.	EXECUTION OF THE CYCLE	77
8.4.	CYCLE OUTCOME	77
8.5.	DOOR OPENING AT CYCLE END	78
8.6.	USER-DEFINED CYCLE	79
9.	MATERIAL STORAGE	81
10.	TEST PROGRAMS	82
10.1.	HELIX/B&D TEST CYCLE	83
10.2.	VACUUM TEST CYCLE	84
10.3.	VACUUM + H/B&D CYCLE	85
10.4.	H ₂ O TEST	86
10.5.	MANUAL INTERRUPTION	87
11.	DRAINING THE USED WATER	89
12.	APPENDIX - PROGRAMS	90
12.1.	SUMMARY TABLE OF 17 220 V - 240 V CYCLES	91
12.2.	SUMMARY TABLE OF 17 120 V CYCLES	93
12.3.	SUMMARY TABLE OF 22 220 V - 240 V CYCLES	95
12.4.	SUMMARY TABLE OF 22 120 V CYCLES	97
12.5.	SUMMARY TABLE OF 28 220 V - 240 V CYCLES	99
12.6.	SUMMARY TABLE OF 28 120 V CYCLES	101
12.7.	STERILIZATION PROGRAM DIAGRAM	105
12.8.	TEST PROGRAM DIAGRAM	107
12.9.	EXAMPLES OF PRINTED REPORTS	108
13.	APPENDIX - MAINTENANCE	109
13.1.	ORDINARY MAINTENANCE PROGRAM	109
13.2.	SCHEDULED MAINTENANCE MESSAGES	110
13.3.	DESCRIPTION OF MAINTENANCE OPERATIONS	111
13.3.1.	GASKET AND PORTHOLE CLEANING	111
13.3.2.	CLEANING THE STERILIZATION CHAMBER AND ITS ADDITIONAL COMPONENTS	111
13.3.3.	CLEANING AND DISINFECTING EXTERNAL SURFACES	111
13.3.4.	BOILER FILTER CLEANING	111
13.3.5.	DOOR LOCK LUBRICATION	112
13.3.6.	DUST FILTER CLEANING	112
13.3.7.	BACTERIOLOGICAL FILTER REPLACEMENT	112
13.3.8.	CLEANING AND DISINFECTION OF FILTER, INTEGRATED DEMINERALISATION FILTER AND WATER TANKS	113
13.3.9.	REPLACEMENT OF THE INTEGRATED DEMINERALISATION FILTER	113
13.3.10.	BOILER GASKET REPLACEMENT	113
13.4.	PERIODIC STERILIZER VALIDATION	114
13.5.	DEVICE SERVICE LIFE	114
13.6.	END-OF-LIFE DISPOSAL	114
14.	APPENDIX - GENERAL PROBLEMS	115
14.1.	TROUBLESHOOTING	115
15.	APPENDIX - ALARM INDICATION	117
15.1.	ALARM INTERVENTION	119
15.2.	ALARM DURING CYCLE	119
15.3.	SYSTEM RESET	119
16.	ALARM CODES	121
16.1.	ERRORS (CATEGORY E)	121
16.2.	WARNING (CATEGORY W)	125
16.3.	INFO (CATEGORY I)	128
16.4.	TROUBLESHOOTING	129
16.4.1.	ERRORS (CATEGORY E)	129
16.4.2.	WARNING (CATEGORY W)	134
16.4.3.	INFO (CATEGORY I)	136
17.	USER PIN RESET	137
18.	APPENDIX – ADDITIONAL COMPONENTS	138
19.	PRINTER CONNECTION	140
20.	APPENDIX - SPARE PARTS AND ADDITIONAL COMPONENTS	141
21.	APPENDIX - TECHNICAL SERVICE	142
22.	APPENDIX - WARNINGS AND LOCAL REGULATIONS	143

1. FOREWORD



The instructions inform the user on how to properly operate the device. It is extremely important to read this manual carefully and thoroughly before using the device.

This publication must not be reproduced, copied or transferred in any manner (electronically, mechanically, via photocopies, translations or other means) without the prior written consent of the manufacturer.

















The manufacturer has a company policy of continual development. Therefore, some of the instructions, specifications and figures given in this manual may slightly differ from the purchased product. The manufacturer reserves the right to make changes to this manual without giving prior notice.

The original text is in Italian; this is a translation from the original in Italian.

1.1. SYMBOLS USED

 <p>NOTE: Pay particular attention to the paragraphs marked with the symbol shown.</p>	 <p>CAUTION: Potential danger for people, environment and property. Follow the procedures indicated in the manual to prevent potential damage to materials, devices and/or property.</p>
---	--

1.2. SYMBOLS ON THE DEVICE

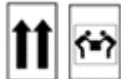
 <p>Potential danger due to high temperature.</p>	 <p>Disposal symbol in accordance with Directive 2012/19/EU.</p>
 <p>Device in compliance with the essential requirements of (EU) Regulation 2017/745 on Medical devices. Notified body: IMQ spa</p>	 <p>Caution!</p>
 <p>Device compliant with the requirements set out in the Directive 2014/68/EU (PED) - category I for 17 I sterilizers; category II for 22 and 28 I sterilizers. Notified body: Rina Services S.p.A.</p>	 <p>Ukrainian national symbol of conformity. UA.TR.101</p>
 <p>ON/OFF switch.</p>	 <p>Fuses 2xT15A 250V.</p>
 <p>The operator's manual is provided in electronic format.</p>	 <p>Medical device.</p>
 <p>Refer to the user manual.</p>	 <p>Manufacturer.</p>
 <p>Serial number of the equipment.</p>	 <p>Manufacturing date of the equipment.</p>
 <p>Product/equipment identification code.</p>	 <p>Model number.</p>
 <p>Unique identifier of the device.</p>	 <p>Product handling instructions.</p>

1.3. STANDARDS AND REGULATIONS

The product described in this manual is manufactured in accordance with the highest safety standards and doesn't represent any danger for the operator if used according to the following instructions. The product is **compliant** with the following **European Directives and Regulations as applicable**:

Regulation (EU) 2017/745,	(EU) Regulation 2017/745 on Medical devices.
2011/65/EU,	(Rohs II) on restriction of hazardous substances in electrical and electronic devices.
2014/68/EU	Pressure Equipment Directive (PED)

Technical standards:

- **EN 13060:2014 + A1:2018** – Small steam sterilizers
- **IEC 61326-1:2020** – Electrical equipment for measurement, control and laboratory use - EMC requirements - Part 1: General requirements
- **CISPR 11:2015 + AMD1:2016 + AMD2:2019** – Industrial scientific and medical equipment - Radio-frequency disturbance characteristics - Limits and methods of measurement
- **IEC 61000-4-2:2008** – Electromagnetic compatibility (EMC) - Part 4-2: Testing and measurement techniques - Electrostatic discharge immunity test
- **IEC 61000-4-3:2006 + AMD1:2007 + AMD2:2010** – Electromagnetic compatibility (EMC) - Part 4-3: Testing and measurement techniques - Radiated, radio-frequency, electromagnetic field immunity test
- **IEC 61000-4-4:2012** – Electromagnetic compatibility (EMC) - Part 4-4: Testing and measurement techniques - Electrical fast transient/burst immunity test
- **IEC 61000-4-5:2014 + AMD1:2017** – Electromagnetic compatibility (EMC) - Part 4-5: Testing and measurement techniques - Surge immunity test
- **IEC 61000-4-6:2013** – Electromagnetic compatibility (EMC) - Part 4-6: Testing and measurement techniques - Immunity to conducted disturbances, induced by radio-frequency fields
- **IEC 61000-4-8:2009** – Electromagnetic compatibility (EMC) - Part 4-8: Testing and measurement techniques - Power frequency magnetic field immunity test
- **IEC 61000-4-11:2020** – Electromagnetic compatibility (EMC) - Part 4-11: Testing and measurement techniques - Voltage dips, short interruptions and voltage variations immunity tests for equipment with input current up to 16 A per phase

1.4. CLASSIFICATION

Medical devices classification

Classification of the device according to the rules laid down in Annex VIII to Regulation (EU) 2017/745: **CLASS IIB**.

EMC classification

The device complies with **CISPR 11 Group 1, Class B** emission limits and meets the applicable immunity requirements of IEC 61326-1:2020 standard for **basic electromagnetic environments**.

1.5. INTENDED USE

The devices covered by this manual are **small sterilizers intended for steam sterilization of invasive and non-invasive medical devices, such as reusable surgical instruments and materials**.

DEVICE INTENDED FOR PROFESSIONAL USE

 The use of the device is strictly reserved to qualified personnel. It must never be used or handled by untrained and/or unauthorised persons.
The device must not be used for the sterilization of fluids, liquids or pharmaceutical products.

 The sterilizer is not a mobile or portable device

1.5.1. IMPORTANT NOTES

 Information contained in this manual are subject to change without notice.
The manufacturer is not responsible for direct, indirect or accidental damage resulting from or relating to the provision or use of this information.
This document may not be reproduced, adapted or translated, in part or in full, without the prior written permission of the manufacturer.

1.6. GENERAL WARNINGS

When using this product, **always** follow the instructions in the manual and never use it for anything other than its intended purpose.

 **The user is responsible for any legal requirements relating to the installation and use of the product. The manufacturer will not be held responsible for any breakage, malfunction, property damage or injury to people in the event that the product is not installed or used correctly, or proper maintenance is not carried out.**

 *For operators in Europe: any serious accident occurred in relation to the device must be reported to Cefla s.c. and to the competent authority of the Member State where the user and/or patient lives.*

Please observe the following precautions in order to avoid injury or property damage:

- Use **ONLY** demineralised and/or distilled water of high quality (IF THE DEMINERALISATION FILTER IS NOT PRESENT IN THE FILLING TANK).

 **The use of water of inadequate quality can severely damage the device. See technical characteristics appendix in this regard.**

- **Do not** pour water or other fluids on the device;
- **Do not** pour flammable substances on the device;
- **Do not** use the system in the presence of flammable or explosive gases or vapours;
- Before performing any maintenance or cleaning intervention, **ALWAYS DISCONNECT** power supply;

 **Whenever it is not possible to disconnect the power supply from the device, or if the external mains switch is distant or not visible to the maintenance technician, place a “work in progress” sign on the external mains switch after having turned it off.**

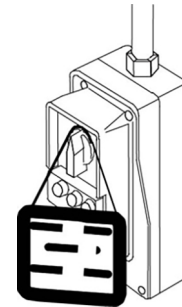

- Make sure the electrical system is grounded according to current laws and/or standards;
- **Do not** remove any label or nameplate from the device; request new ones, if necessary;
- Use **only original spare parts**.

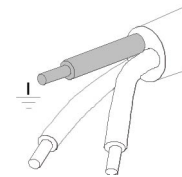

 **Failure to comply with the above exempts the manufacturer from all liability.**

1.7. RESIDUAL RISKS

FOR THE USER

- Contamination due to improper handling of the load;
- Burn by contact with hot surfaces or fluids.

FOR THE PATIENT

- Contamination due to unsterilized material caused by wrong cleaning treatment before sterilization;
- Contamination due to implementation of a wrong reuse process;
- Contamination due to material unsuitable to sterilization or not compliant with instructions for use;
- Contamination due to unsterilized material caused by wrong final assessment of sterilization process;
- Contamination due to missing or wrong scheduled maintenance;
- Contamination due to missing periodic validation.

1.8. INFORMATION ON MITIGATION OF RESIDUAL RISKS

FOR THE USER

Contamination due to improper handling of the load.

See chapter PREPARING THE MATERIAL.

Burn by contact with hot surfaces or fluids.

To extract the sterile material, once the sterilization process has been completed with saturated steam at 121° or 134°, proceed as follows:

- Always wear PPE suitable for the handling of hot material and gloves of appropriate material and thickness;
- Clean your gloved hands with a germicide detergent;
- Always use the special tool, supplied as standard, to extract the trays from the sterilization chamber;
- Avoid any contact of trays and material with contaminated and/or non-heat-resistant surfaces;
- Handle the sterile material making sure not to damage any packages, bags and containers serving as a barrier.

FOR THE PATIENT

Contamination due to unsterilized material caused by wrong cleaning treatment before sterilization.

See chapter TREATING THE MATERIAL BEFORE STERILIZATION.

Contamination due to implementation of a wrong reuse process.

Make sure to use sterile material.

Contamination due to material unsuitable to sterilization or not compliant with instructions for use.

- Check that the contaminated material is compatible with the selected sterilization process;
- Immediately separate the materials to be sterilized from those that must not be subjected to such process or are not able to withstand it.

Contamination due to unsterilized material caused by wrong final assessment of sterilization process.

The sterilization process electronic control system monitors the various phases, at the same time checking that the various parameters are respected; if any type of anomaly is encountered during the cycle, the program is immediately interrupted, generating an alarm identified by a code, with a relative message explaining the nature of the problem.

Furthermore, the sterilization process can be checked by means of:

CHEMICAL INDICATORS

that monitor the sterilization process by providing information, together with the control of physical and biological parameters, on the conditions occurred in the sterilization chamber during the process.

The final toning of the process indicator does not certify that the product is sterile but only that the device has been subjected to a sterilization process. If the toning does not occur, the operator in charge of releasing the sterile material, that must not be used, must find out why.

PHYSICAL INDICATORS

They include the reading of machine data and the execution of specific tests indicated during the validation phase for that specific cycle/load/autoclave. This control system can include:

- Direct reading of the synoptic system (thermometer, pressure gauge, recorder, etc.);
- Reading of prints/labels/files on which the data detected by the synoptic system are stored (parameters);
- Execution of specific tests (Vacuum Test, Bowie & Dick Test, Helix Test).

The operator in charge of the process certifies the validity of the load at the end of every cycle by means of the parametric release.

Contamination due to missing or wrong scheduled maintenance.

The sterilizer, based on a preset programming, displays a warning message relating to the scheduled maintenance necessary to ensure the good operation of the device.

Contamination due to missing periodic validation.

See chapter PERIODIC STERILIZER VALIDATION.

1.9. ELECTROMAGNETIC SAFETY

Applied standard and expected electromagnetic environment

This device complies with the EMC requirements specified in **IEC 61326-1:2020**.

This is intended to be used in a **basic electromagnetic environment**. This environment typically includes residential, commercial and light industrial locations, characterised by being directly supplied from the public low-voltage power supply network.

The equipment is classified as **Group 1** and **Class B** according to **CISPR 11**. This classification indicates that the equipment is suitable to be used in domestic environments and can be used in any location, including residential environments, even when connected directly to the public low-voltage power supply network.

Warning on emissions when connected to a test object: when the device is connected to a test object, emissions exceeding the threshold required by IEC 61326-1 may occur.

In order to keep compliance with EMC standards and avoid electromagnetic interference with other equipment, operators must ensure that the device is installed and used in accordance with the instructions provided.

Information on electromagnetic emissions		
The product meets the emission requirements for Class B equipment according to CISPR 11. For Group 1 and Class B equipment, the thresholds, measurement methods and provisions specified in sub-clause 6.2 of CISPR 11:2015/AMD1:2016/AMD2:2019 apply.		
Emission test	Compliance	Electromagnetic environment
RF emissions	Group 1	Equipment in which radio frequency energy is intentionally generated and/or used in a conductively coupled manner, necessary for the internal operation of the equipment itself.
CISPR 11	Class B	Equipment suitable to be used in residential environments and in structures directly connected to a low-voltage power supply network that supplies buildings used for domestic purposes.
Requirement	Applicable standard	Result
Disturbance voltage (Conducted emissions)	CISPR 11 (clause 7.2 of IEC 61326-1:2020 standard)	P
Disturbance due to electromagnetic radiation (Radiated emissions)	CISPR 11 (clause 7.2 of IEC 61326-1:2020 standard)	P

Performance levels under electromagnetic immunity conditions

Immunity tests were conducted in accordance with **performance criteria A and B** of IEC 61326-1:

- **Performance criterion A:** The equipment shall continue to operate as intended during and after the test. No performance degradation or loss of functionality below a performance level specified in the user documentation is allowed. In the case of continuous electromagnetic phenomena, an allowable performance loss can be tolerated if the equipment recovers without user intervention and this is clearly documented. No changes in operating status or loss of data are allowed.
- **Performance criterion B:** The equipment shall continue to operate as intended after the test. No performance degradation or loss of functionality below a performance level is allowed. During testing, an acceptable loss of performance is permitted if detailed in the EMC test plan. An unintentional change in operating status is allowed if it can be self-recovered. No loss of stored data is allowed.

The sterilizer is suitable to be used in the specified electromagnetic environment. The immunity test results have demonstrated that there were no unintended interruptions of the sterilization cycle without having been clearly notified, that no loss of cycle data occurred and that the machine remained responsive.

Requirement (immunity test)	Applicable standard	Result
Electrostatic discharges (ESD)	IEC 61000-4-2	P
Radiated electromagnetic fields, RF	IEC 61000-4-3	P
Power frequency magnetic fields	IEC 61000-4-8	P
Fast transient/burst	IEC 61000-4-4	P
Injected currents (RF common mode)	IEC 61000-4-6	P
Overvoltage (Surge Test)	IEC 61000-4-5	P
Voltage drops, short interruptions and voltage variations	IEC 61000-4-11	P

1.10. NETWORK AND DATA SECURITY

The sterilizer includes an Ethernet connection and a Wi-Fi module that allows connection to the local network and useful services, including device troubleshooting and firmware updates.

The Wi-Fi module supports IEEE 802.11 b, g, n with WEP, WPA2-PSK encryption standards in the 2.4 GHz range.

Since the connection security depends on the wireless infrastructure configuration (router or access point), Wi-Fi connection protection is an important element for data protection.

For maximum safety, make sure your network is configured for WPA2 protection.

Avoid placing devices connected to your network in places that are accessible to the public without surveillance.

When using USB pendrives to download cycle data, check that data are copied to a supervised disk and that back-ups are performed regularly.

Tips for protecting a new network

- Change the default network name (SSID) when installing new access points, routers and gateways.
- Change the administrative credentials (user name and password) that control the settings of your Access point/Router/Gateway.
- Enable Personal WPA2 (also known as WPA2-PSK) with AES encryption on all client devices.
- Create a network passphrase that meets the recommended guidelines.
- Verify that a firewall is enabled and configured correctly.

Checking that an existing network is secure

- If your network is configured for a very old security system (WEP or WPA), it is recommended to switch to WPA2 as soon as possible.
- Select an effective network passphrase. In general, increasing the length, complexity and randomness improves the quality of a passphrase. A passphrase must not contain a word found in a dictionary and must not include personal information (identification number, name, address, etc.).
- Periodically changing the passphrase on the network also increases security.
- Ensure that user access and logs recorded on your infrastructure (PCs, devices, etc.) are managed correctly.
- Verify that a firewall is enabled and configured correctly.

2. CONTENTS OF THE PACKAGE



Check the integrity of the product package upon receipt.

2.1. DIMENSIONS AND WEIGHT

Once the package is opened, check that:

- The supply matches the specifications of the order (see the delivery note);
- There is no visible damage to the product.

Dimensions and weight

A Height	600 mm
B Width	600 mm
C Depth	700 mm
Total weight	61 kg

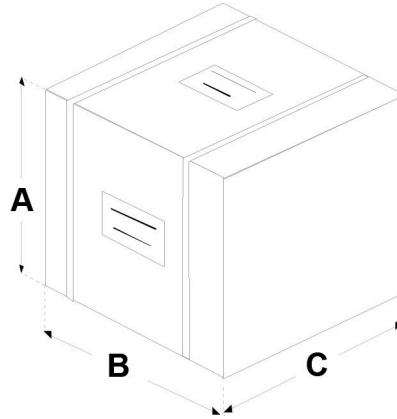

In case of wrong delivery, missing parts or any type of damage, inform immediately and in detail the reseller and the carrier that made the delivery.

2.2. DESCRIPTION OF THE CONTENT

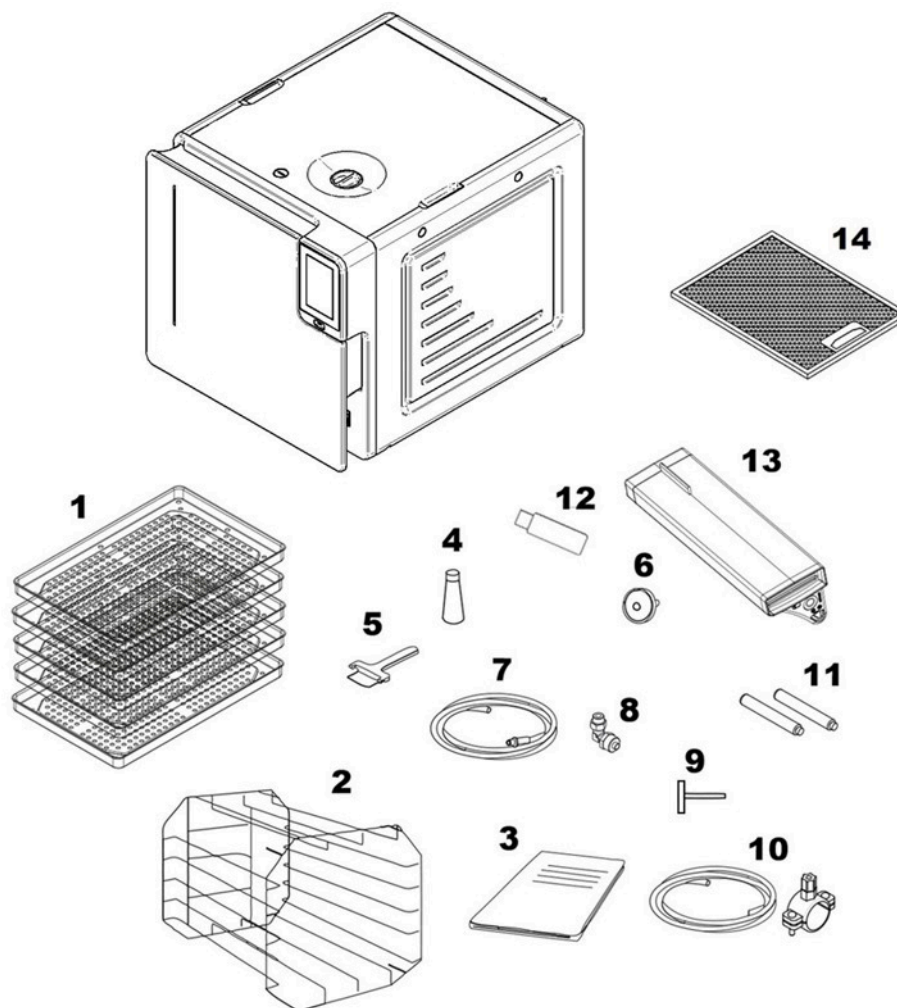

In addition to the sterilizer, the package contains:

- | | |
|---|---|
| <p>1 Instrument trays:
• 5 pcs for 17 and 22;
• 6 pcs for 28.</p> <p>2 Tray holder support;</p> <p>3 Operator's documentation and safety valve's EC Declaration of Conformity;</p> <p>4 Lubricant for door locking mechanism;</p> <p>5 Tray extractor;</p> <p>6 Additional bacteriological filter;</p> <p>7 Rubber hose with quick coupling for manual water drainage;</p> | <p>8 Angled union + straight union;</p> <p>9 T-shape tubular wrench (for door manual unlocking);</p> <p>10 Plastic tube for direct water drainage, with fastening clamp;</p> <p>11 Rear spacers;</p> <p>12 USB key containing:
User manual and DataSter Software;</p> <p>13 Integrated demineralisation filter;</p> <p>14 Dust filter.</p> |
|---|---|

2.3. PRODUCT HANDLING

The packed product must be handled using, where possible, suitable mechanical means (lift truck, pallet truck, etc.) and following the indications on the package.

In case of manual handling, the product must be lifted by two persons using the suitable available means.

Once the sterilizer has been removed from the package, it must be lifted by two persons using the suitable available means and handled, if possible, using a truck or similar means.



We recommend to transport and store the device at a temperature not below 5°C. Extended exposure to low temperatures may damage the product.



Store the original package and use it for any transport of the device. Using a different package may damage the product during shipping.



Before transport, leave the device turned off for about 30 minutes after the last program finishes and drain the filling and discharge tanks so that all the internal parts will have time to cool down.

2.4. CONDITIONS FOR STORAGE AND TRANSPORT

TEMPERATURE: between +5° C and +70° C

HUMIDITY: between 20% and 80%

PRESSURE: between 0.5 and 1.1 bar (50 and 110 kPa)

3. GENERAL DESCRIPTION - PRODUCT PRESENTATION

3.1. GENERAL CHARACTERISTICS

The device is an electronic water steam sterilizer, entirely operated by a micro-processor, with a large, printed stainless steel sterilization chamber. It is characterized by an advanced fractionated vacuum system for the complete removal of air, even from hollow, porous materials, and an effective final vacuum drying phase capable of eliminating all traces of humidity from any load.

The exclusive steam generation system, the effective hydraulic circuit and the electronic management (integrated by high-precision sensors) ensure a high execution speed of the process and an excellent stability of thermodynamic parameters. Moreover, its Process Evaluation System constantly monitors all the machine "vital" parameters in real-time, guaranteeing absolute safety and a perfect result.

The device offers users 6 sterilization programs (one of which completely programmable), all equipped with customisable, optimised drying for the fast, effective sterilization of the various types of load (instruments and materials) used in a medical environment. All the cycles can immediately be selected on the clear TOUCH screen, which also allows extensive configuration of the device according to the user's needs.

A lighting system is also activated when the door of the working area in front of the sterilization chamber is opened, allowing performing daily operations with increasing ease and comfort. There is also a remote light signalling device integrated into the front panel of the device.

Like in the best tradition, also the new range of autoclaves features the most complete and advanced safety systems available today, to ensure the user maximum safety and minimise any potential electrical, mechanical, thermal or functional faults.



For the description of safety devices, refer to technical characteristics appendix.

3.2. TECHNICAL CHARACTERISTICS

3.2.1. SUMMARY TABLE

Device	WATER STEAM STERILIZER		
	17	22	28
Class according to Reg. (EU) 2017/745	IIb		
Manufacturer	Cefla s.c. Headquarters Via Selice Provinciale 23/A – 40026 Imola (BO) IT		
Input voltage	220 V - 240 V~ 50 Hz 220 V - 240 V~ 60 Hz 120V~ 60 Hz		
Network fuses (6.3 x 32 mm)	2x T15A 250V		
Electronic board fuse (5 x 20 mm)	F1: T4A 250V (24V DC board input)		
Nominal power	2,300 W 1,440 W (120V~ / 60 Hz)		
Insulation class	Class I		
Installation category (according to EN 61010)	Cat. II		
Operational environment	Indoor use HUMID LOCATION (EN 61010 extended environmental conditions)		
A-weighted sound power level (ISO 3746)	< 67 dB (A)		
Degree of protection (IP code) (EN 60529:1991+A1:2000+A2:2013)	IP21		
Environmental operating conditions	Temperature: +15°C + +35°C Relative humidity: between 20% and 80% max non-condensing Altitude: min -100 m / max. 3,000 m (a.s.l.)		
External dimensions (HxWxD) (rear connections excluded)	490 x 500 x 610 mm		
Net weight: unladen unladen, with tray holder support and trays unladen, with tray holder support, trays and water at MAX level	approx. 44 kg approx. 47 kg approx. 53 kg	approx. 47 kg approx. 50 kg approx. 56 kg	approx. 48 kg approx. 51 kg approx. 57 kg
Sterilization chamber dimensions (D x D)	250 x 350 mm	250 x 450 mm	280 x 450 mm
Sterilization chamber total volume	approx. 17 l (0.017 cu. m)	approx. 22 l (0.022 cu. m)	approx. 28 l (0.028 cu. m)
Sterilization chamber usable volume (with tray holder support inserted)	approx. 10 l (0.010 cu. m)	approx. 13 l (0.013 cu. m)	approx. 19 l (0.019 cu. m)
Sterilization chamber usable dimensions	17 l (1.38x1.55x2.97) dm / 6.4 cu. dm	22 l (1.38x1.55x3.97) dm / 8.5 cu. dm	28 l (1.72x1.66x3.96) dm / 11.3 cu. dm
Distilled water tank capacity (filling)	approx. 6 l (water at MAX level) approx. 1.5 l (water at MIN level)		
Sterilization programs	5 standard programs + 1 program defined by the user		
Test programs	Helix/B&D Test Vacuum Test Vacuum + Helix/B&D Test		
USB connection	USB 2.0 CONNECTION FAT 16/ FAT 32		
Printer connection	Serial RS232 (printer cable max length 2.5 m)		
Printer insulation class:	Class I or Class II		
Printer power supply standard:	Compliant with Standard EN 60950. (The safety of the sterilizer may be compromised in case of uncertified printer power supply unit)		
120 V 60 Hz Main power cord	NEMA 5-15 plug 125 V-15A Cable length 2.5 m C19 connector according to IEC 60320		
220-240 V 50 Hz Main power cord	Plug CEE 7 / VII IEC 250V-16A 50 Hz Cable length 2.5 m C19 connector according to IEC 60320 UL 498, CSA C22.2		

Device	WATER STEAM STERILIZER		
	17	22	28
220 V 60 Hz Main power cord:	NEMA 6-15P plug 250V-15A Cable length 2.5 m C19 connector according to IEC 60320		
Ethernet connection	RJ45 (max. cable length 29 m)		
Wi-Fi	802.11 b/g/n (2.4 GHz); WEP / WPA / WPA2-PSK encryption		
Bacteriological filter (filter element in PTFE)	Porosity: 0.027 microns Connection: male connector 1/8" NPT		
Maximum flow of drained water	1 l/min.		
Temperature of drained water	50° C		
Maximum temperature of drained water	90° C		
Total heat in Joule sent by the sterilizer to the surrounding air in 1 hour of continue operation	17 l = 3.6 MJ	22 l = 4 MJ	28 l = 5.4 MJ
Manoeuvre/handling space	1 m x 1 m		

Device	17	22	28
Class (according to PED Directive 2014/68/EU)	Category I	Category II	Category II
Working pressure	-0.8 ÷ 2.4 barg	-0.8 ÷ 2.4 barg	-0.8 ÷ 2.4 barg
Safety device set	2.4 barg	2.4 barg	2.4 barg
PT	500 kPa (abs)	500 kPa (abs)	500 kPa (abs)
PS	2.4 barg	2.4 barg	2.4 barg
TS	10 ÷ 140 °C	10 ÷ 140 °C	10 ÷ 140 °C
Fluid Group	2	2	2

3.3. SAFETY DEVICES

The sterilizer is equipped with the following safety devices for which we provide a brief description of their function:

- **Network fuses (see data in summary table)**
Protection of the whole device against possible failures of heating elements.
Action: power supply interruption.
- **Electronic circuit protection fuses (see data in summary table)**
Protection against possible failures of the primary circuit of the transformer and of low voltage users.
Action: interruption of one or more low voltage circuits.
- **Thermal circuit-breakers on mains voltage windings**
Protection against possible overheating of pump motors.
Action: temporary cut-off (until cooling) of the winding.
- **Safety valve**
Protection against overpressure in the sterilization chamber.
Action: release of the steam and restoration of the safety pressure.
- **Safety thermostat with steam generator manual reset**
Protection against steam generator overheating.
Action: cut-off of the electricity to the steam generator.
- **Safety thermostat with chamber heating element manual reset**
Protection against overheating of the heating elements of the container under pressure.
Action: cut-off of the electricity to the chamber heating element.
- **Door position safety microswitch**
Confirmation of the correct closing position of the door of the container under pressure.
Action: signalling of wrong door position.
- **Motor-driven door lock mechanism with electromechanical protection (pressure switch)**
Protection against accidental opening of the door (even in a blackout).
Action: prevents accidental opening of the door during a program.
- **Door locking mechanism safety microswitch**
Striker for the correct closing position of door locking system.
Action: signalling of failed or wrong operation of door locking mechanism.
- **Self-levelling hydraulic system**
Plumbing system structure for the spontaneous levelling of the pressure in the case of a manual interruption of the cycle, alarm or blackout.
Action: automatic restoration of atmospheric pressure in the sterilization chamber.
- **Integrated system for evaluating the sterilization process**
Continuous verification of the sterilization process parameters entirely managed by microprocessor.
Action: immediate interruption of the program (in case of malfunction) and generation of alarms.
- **Sterilizer operation monitoring**
Real-time oversight of all significant parameters when the machine is powered.
Action: generation of alarm messages (in the case of anomaly) with possible interruption of the cycle.

3.4. WATER SUPPLY CHARACTERISTICS

The sterilizer is equipped with a demineralisation filter fitted inside the filling tank, which allows supplying the device with standard water from the mains. The quality of the water treated by the integrated filter is checked automatically through a conductivity sensor.

If the demineralisation filter is not present, ONLY use demineralised/distilled water having the following characteristics to supply the sterilizer.

DESCRIPTION	VALUES IN THE WATER SUPPLY	VALUES INSIDE RESIDUAL
DRY CONDENSATE	< 10 mg/l	< 1 mg/l
SILICON OXIDE SiO ₂	< 1 mg/l	< 0.1 mg/l
IRON	< 0.2 mg/l	< 0.1 mg/l
CADMIUM	< 0.005 mg/l	< 0.005 mg/l
LEAD	< 0.05 mg/l	< 0.05 mg/l
HEAVY METAL RESIDUES (iron, cadmium and lead excluded)	< 0.1 mg/l	< 0.1 mg/l
CHLORIDES	< 2 mg/l	< 0.1 mg/l
PHOSPHATES	< 0.5 mg/l	< 0.1 mg/l
CONDUCTIVITY AT 20°C	< 15 µS/cm	< 3 µS/cm
pH	5 - 7	5 - 7
ASPECT	colourless, transparent, without sediment	colourless, transparent, without sediment
HARDNESS	< 0.02 mmol/l	< 0.02 mmol/l

 When buying distilled water, make always sure that the quality and characteristics declared by the manufacturer are compatible with those specified in the table.

 The use of water for steam generation with contaminant levels exceeding those indicated in the above table can greatly shorten the sterilizer lifetime. This could also result in an increase of oxidation in the most sensitive materials as well as in an increase of limescale residues on generator, boiler, internal supports, trays and instruments.

3.5. FRONT SIDE

- 1 TOUCH control panel
- 2 Door
- 3 Model
- 4 Dust filter

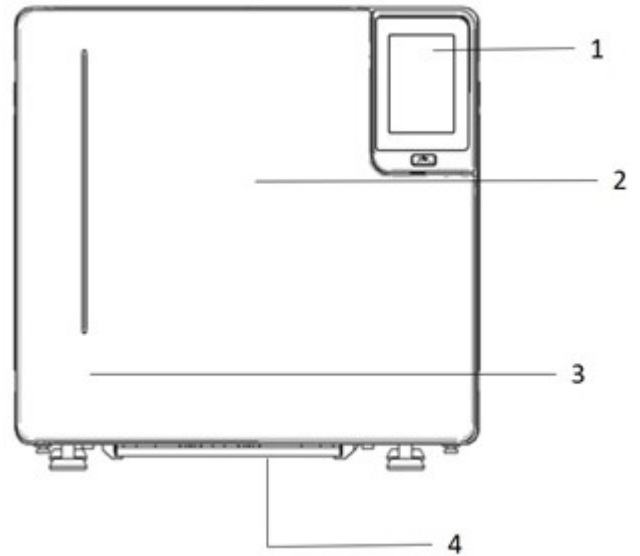

- 1 Steam diffuser
- 2 Sterilization chamber
- 3 Bacteriological filter
- 4 Door locking system
- 5 Power switch
- 6 Chamber drain filter
- 7 Distilled water top-up quick coupling
- 8 Distilled water drainage quick coupling
- 9 Waste water drainage quick connector
- 10 Door

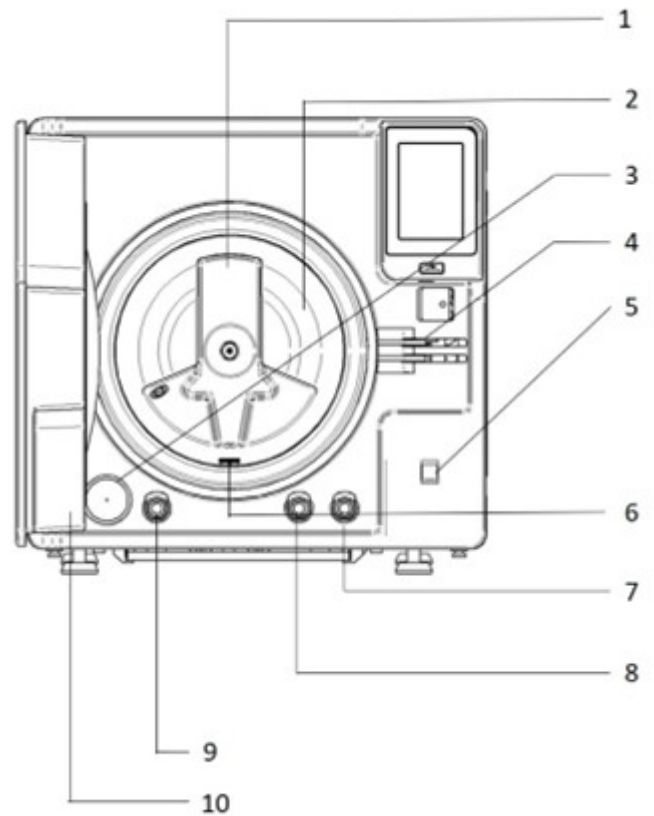

3.6. REAR SIDE

- 1 Fastening slots for rear spacers
- 2 Heat exchanger
- 3 Safety valve
- 4 Connection for direct water drainage
- 5 Connection for automatic distilled water filling (only for Ev AUX kit, PURE 100 / 500 and external pump kit)
- 6 Mains fuse holder fastening screws
- 7 Automatic filling electrical connection (only for EV AUX kit, PURE 100 / 500 and external pump kit)
- 8 Serial cable connection
- 9 Ethernet cable connection (max. length 29 m)
- 10 Data plate
- 11 SERIAL NUMBER LABEL
(See image *)

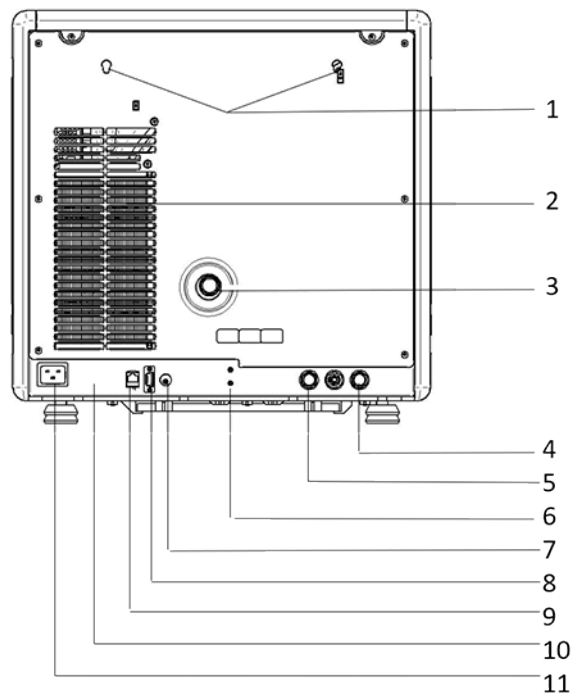

(*)

MANUFACTURER			
MODEL	REF	TYPE	CODE
MADE IN			SYMBOLS
TECHNICAL DATA			
TECHNICAL DATA			
TECHNICAL DATA			
SN	SERIAL NUMBER		MANUFACTURING DATE

3.7. DISPLAY ICONS

 | The screens in the following pictures may vary in shapes and colours, but their contents are the same as shown on the sterilizer display.

- A Sterilization cycles
 - B Wi-Fi status
 - C Date/Time
 - D Home screen
 - E Settings
 - F Sterilizer information
 - G Link to download Cycles report to USB
 - H Cloud status
- Swipe to navigate the Home screen.

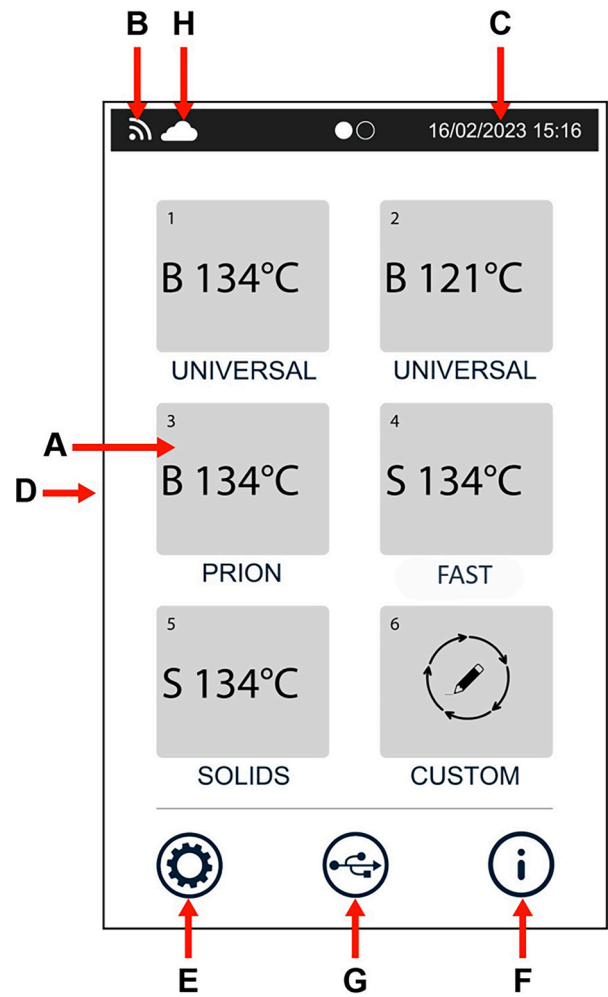

 | Other particular symbols relating to the various conditions of use will be described in the relative paragraphs.

3.8. DESCRIPTION OF A STERILIZATION CYCLE

The sterilization program of the sterilizers can be effectively described as a succession of phases, each one having a dedicated function.

For example, the universal program (cycle B, 134°C - 4'): after loading the material in the chamber, closing the door, selecting the program and starting the cycle (after locking the door opening mechanism), the following sequence will be suggested (see the graph below):

- 1 Preheating the generator and sterilization chamber;
- 2 Removing the air and penetration of steam in the material through a series of vacuum (extraction of the fluid from the sterilization chamber) and pressure (injection of steam into the chamber) phases;
- 3 Raising the pressure, with the consequent increase in the temperature of the steam, until reaching the conditions required for sterilization (in the example, 134°C);
- 4 Stabilizing the pressure and temperature;
- 5 Sterilizing for the required time (in the example, 4 minutes);
- 6 Depressurizing the sterilization chamber;
- 7 Vacuum-drying phase;
- 8 Ventilating the load with sterile air;
- 9 Bringing the pressure of the sterilization chamber back to the atmospheric level.

Having reached this last phase, you can unlock the door and remove the load from the sterilization chamber.

It should be emphasized that phases 1, 3, 4, 6 and 9 are identical in all cycles, with slight variations of duration that are solely dependent on the quantity and consistency of the load and the heating conditions of the sterilizer while phases 2, 5, 7 and 8 clearly vary their configuration and/or duration on the basis of the cycle selected (and, as a consequence, the type of load) and the choices made by the user.

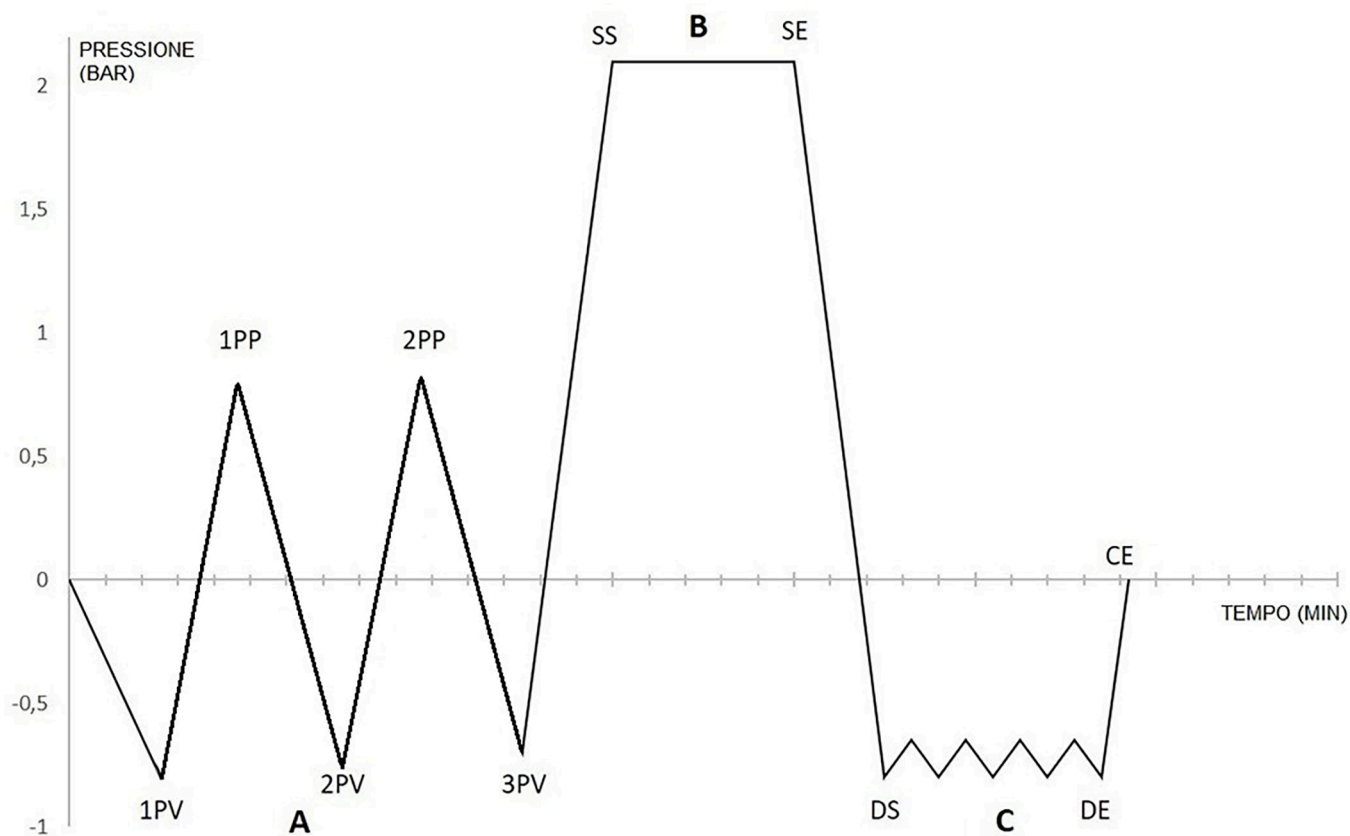

A	FRACTIONATED VACUUM	2PV	SECOND VACUUM PULSE	DS	DRYING START
B	PROCESS	2PP	SECOND PRESSURE PULSE	DE	DRYING END
C	VACUUM DRYING	3PV	THIRD VACUUM PULSE	CE	CYCLE END
1PV	FIRST VACUUM PULSE	SS	STERILIZATION START		
1PP	FIRST PRESSURE PULSE	SE	STERILIZATION END		



Please refer to the programs appendix for more details on programs.

4. INSTALLATION



The safety of every system which integrates the device is responsibility of the system assembler.

The first and essential step for a proper operation of the sterilizer, its durability over time and complete use of its features is a correct and careful commissioning. Moreover, this precaution will avoid the danger of physical injury or property damage, not to mention malfunctions and damage to the device.

Please follow **meticulously** the instructions contained hereafter in this chapter.



Technical service department (see appendix) is available for any doubt or further information. The sterilizer is placed on the marked only after having passed all the checks required. It does not require any additional calibration for commissioning.

Dimensions and weight	17	22	28
A Height (total)		490 mm	
B Width (total)		500 mm	
C Depth (excluding rear unions)*		610 mm	
Total weight	47 kg	50 kg	51 kg



*The sterilizer can be positioned on a surface only 550 mm deep

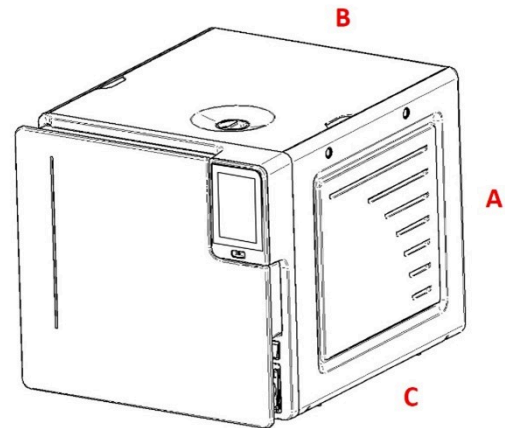

4.1. OVERALL DIMENSIONS

Centre distance and maximum overall dimensions of the sterilizer feet, with and without rear spacers.

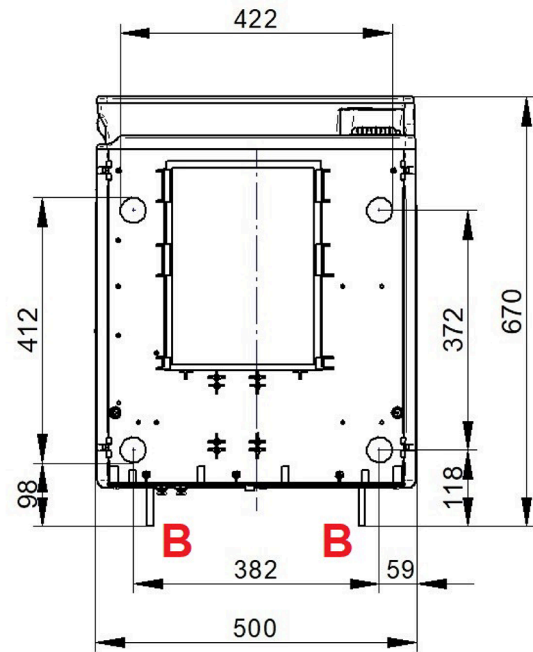
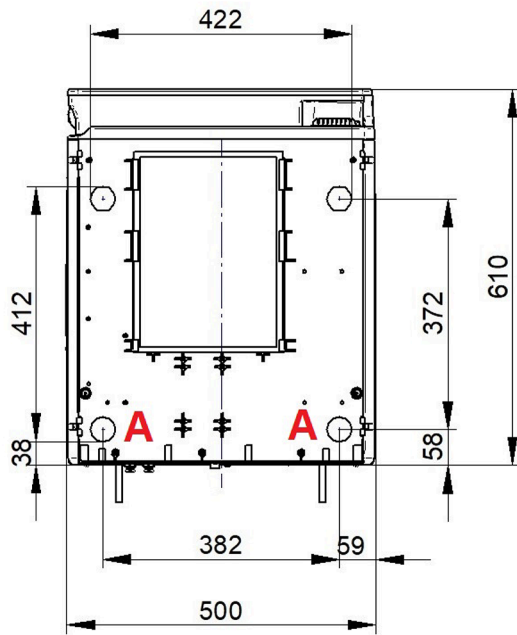

- A Feet
- B Rear spacers

4.2. DIMENSIONS OF THE RECESSED INSTALLATION COMPARTMENT

When installing the sterilizer inside a cabinet, you must provide adequate space all around the device to provide effective ventilation, as well as an opening at the top (385 sq.cm) ensuring an adequate air flow and the consequent optimum cooling of the heat exchanger.

 Mount the rear spacers supplied to ensure that the sterilizer is placed at the correct distance from the wall.

The compartment where the sterilizer will be installed must have the following minimum dimensions:

COMPARTMENT DIMENSIONS	CHAMBER VOLUME 17-22-28 L
Height	520 mm WITH FRONT FILLING OR AUTOMATIC FILLING KIT
	WITH TOP FILLING provide for a sliding surface with suitable load bearing capacity (approx. 90kg)
Width	550 mm
Depth	600 mm
Opening	385 sq.cm

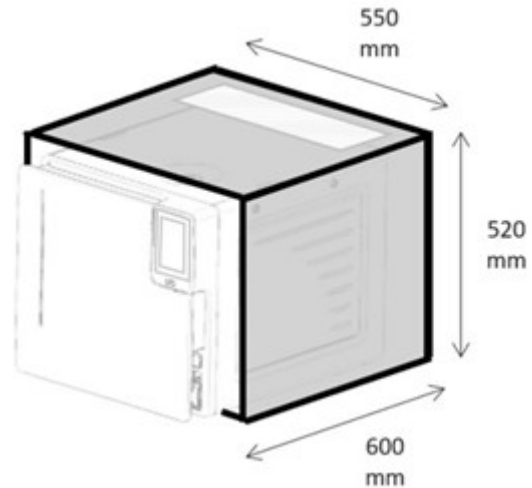

 In case of water manual filling from the top, the installation compartment must be equipped with an extractable table with suitable load bearing capacity (approx. 90Kg)

 Compartment dimensions lower than those shown may compromise the correct circulation of air around the device and may not provide adequate cooling, with the consequent deterioration of performance and/or possible damage.

 If the main switch is inaccessible when installed in the compartment, use an electric plug that incorporates an on/off switch. Do not remove the upper cover nor any other external part. The device must be completely installed in the compartment. Please refer to appendix "technical characteristics" for complete data specifications.

4.3. GENERAL PRECAUTIONS FOR INSTALLATION

To ensure a correct operation of the device and/or avoid risk situations, respect the following **warnings**:

- Install the sterilizer on a flat and perfectly horizontal surface;
- Make sure that the support surface is strong enough to support the device weight (about 90 kg, complete with water in hydrostatic test configuration) **and has the following minimum dimensions: Width 550 mm, Depth 600 mm**;
- Leave adequate space for ventilation all around the sterilizer, in particular in the rear area;
- If the device is built-in into a cabinet, be sure to respect the warnings in the previous paragraph, avoiding any obstructions of the air intakes;
- Do not install the sterilizer too close to tubs, sinks or similar places, avoiding contact with water or liquids. This could cause short circuits and/or potentially dangerous situations for the operator;
- Do not install the sterilizer in excessively humid or poorly ventilated environments;
- Do not install the machine in environments with flammable and/or explosive gasses or vapours;
- Install the device so that the supply cable is not bended or squeezed.
- The power cable must freely run all the way to the electrical outlet;
- Install the device so that any external filling/drainage pipes are not bent or squeezed.

4.4. POWER SUPPLY

The electrical system to which the sterilizer will be connected must be suitably dimensioned according to the electrical characteristics of the device. Plate data are shown in the TECHNICAL SPECIFICATIONS table and on the back of the machine.

4.5. ELECTRICAL CONNECTIONS

This information is shown on the back of the machine.

The sterilizer must be connected to a socket of the electric system having adequate capacity for the absorption of the device and properly earthed, in accordance with laws and/or regulations in force.

The socket must be properly protected through magneto-thermal and differential circuit breakers having the following characteristics:

- Rated current I_n : **16 A**
- Residual current $I_{\Delta n}$: **0.03 A**



The manufacturer is not responsible for any damage caused by the installation of the sterilizer with unsuited and/or not properly earthed electric systems.



*Always connect the power cord directly to the power outlet.
Do not use extensions, adapters or other additional components.*

4.6. DIRECT CONNECTION TO CENTRALIZED DRAINING POINT

 If an automatic filling system is connected (EV AUX, PURE 100 / 500 kit and external pump kit), the direct discharge connection must be used. In case of fault or failure, this system allows any excess water produced by the automatic filling system to flow into the centralized draining point, thus preventing flooding.

- Remove the cap holding clip and the cap on the rear of the autoclave;
- Fit the plastic tube on the elbow union (supplied);
- Fit the union and then refit the clip;
- Fasten the clamp (supplied) to the drain siphon;
- Cut the tube to the right length and insert its free end into the centralized draining point union locking it with the dedicated ring nut.

 Make sure that the tube is not bent, crushed or obstructed in any way.

The following diagram provides an indicative arrangement of the components:

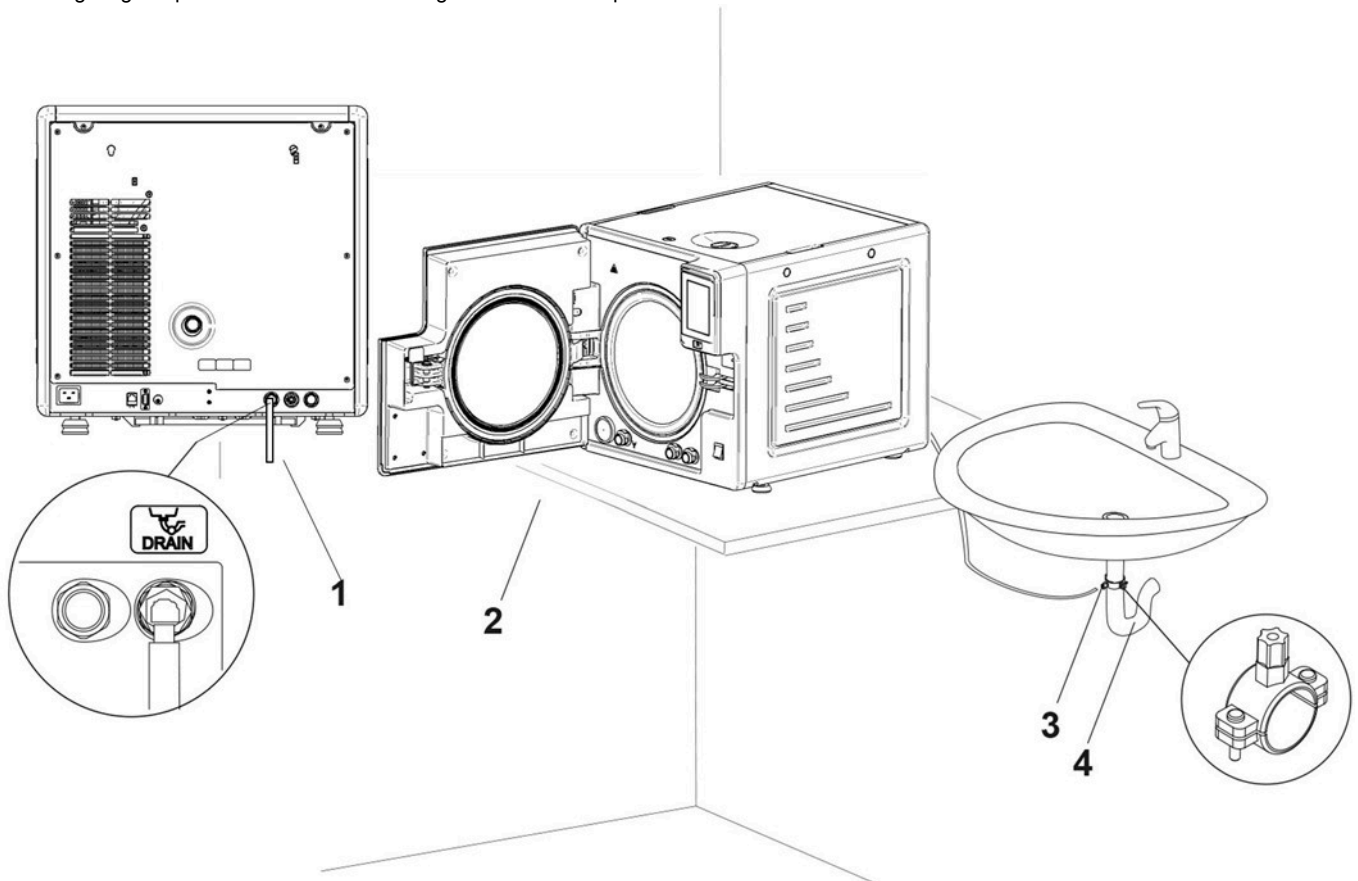

- 1 Plastic hose for direct water drainage;
- 2 Resting surface;
- 3 Clamp;
- 4 Drain siphon.

 The position of the union of the centralized draining point must be lower than the resting surface of the sterilizer. Otherwise, the tank may not be emptied correctly.

5. FIRST START-UP

 | The time required to start the sterilizer is approximately 30 seconds.

5.1. POWER ON

Once the sterilizer has been correctly installed, turn it on with the main switch on the front right-hand side of the machine.

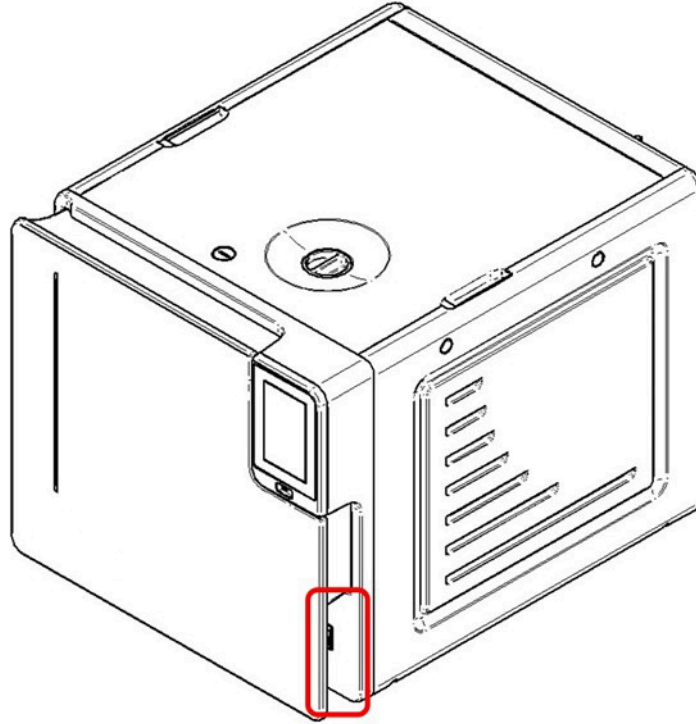

Do not turn on the sterilizer if USB key is inserted.

When the device is first turned on, the display shows the selection of LANGUAGE, DATE AND TIME settings.

Select the correct values for each item by scrolling (up or down).

Confirm your selections with the ✓ icon.

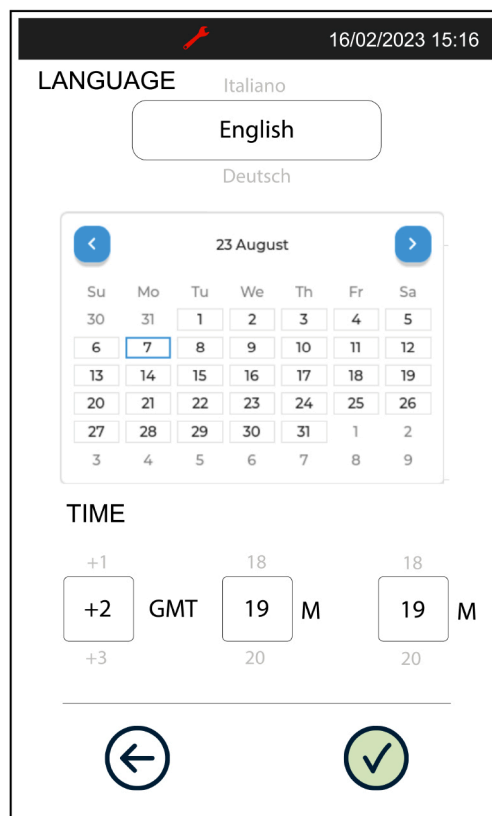

At first start-up, once LANGUAGE, DATE AND TIME have been set, the PREHEATING screen appears.

For the configuration of the preheating parameters, refer to paragraph PREHEATING.

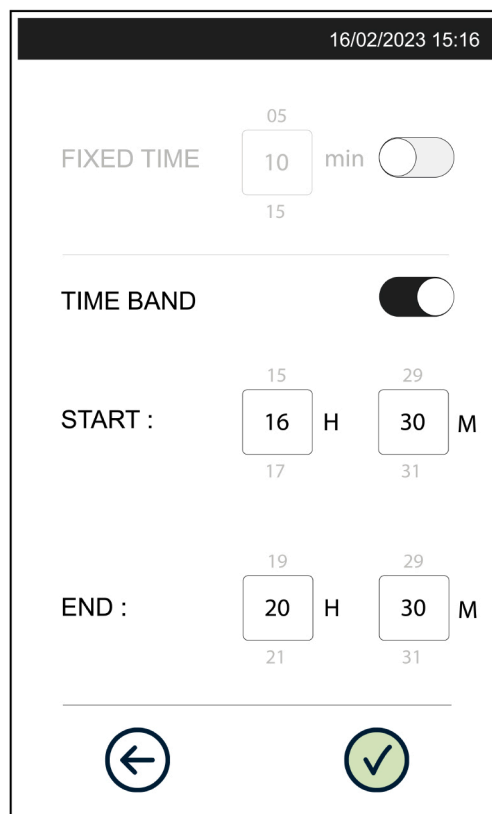

5.2. MAIN MENU

At the end of starting procedure the main menu is displayed on the side.

The sterilizer waits for the program selection (see Chapters STERILIZATION CYCLES and TEST PROGRAMS).

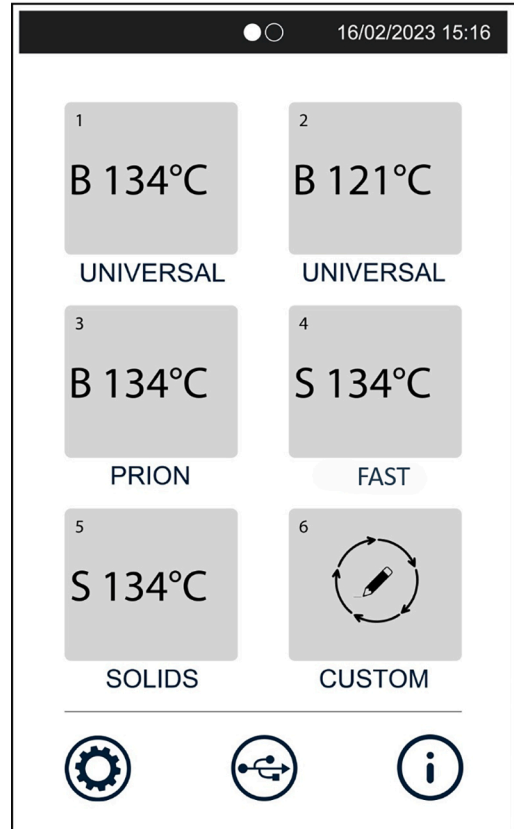

5.3. INTEGRATED DEMINERALISATION FILTER

This device has been designed to demineralise drinkable water from the water mains to make it usable for the supply of the steam sterilizer. The INTEGRATED DEMINERALISATION FILTER is an ion-exchange water treatment system integrated in the autoclave load tank. It is a cutting-edge device with an attractive design which combines high performance, user-friendliness and a small size compared to similar water treatment systems. Its robust bacteriostatic plastic case, compliant with EN 22196 standard, and its ergonomic compact shape allow maintaining a high hygiene level in a light and small-sized filter, thanks to the installation system inside the load water tank.

For a proper operation of the INTEGRATED DEMINERALISATION FILTER, the first essential condition is a correct installation, which avoids any malfunction or damage to the device. Please follow meticulously the instructions contained hereafter.

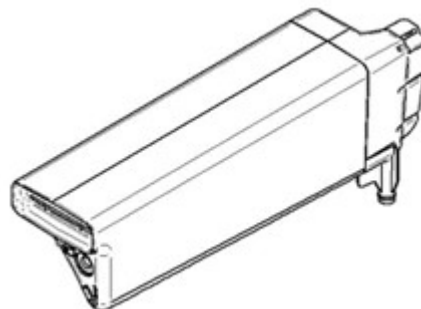

 Only install the demineraliser on compatible autoclaves. The technical assistance service is at your disposal for further information or any doubt you may have.

5.3.1. SAFETY PRECAUTIONS

In case of contact with the ion-exchange resins inside the INTEGRATED DEMINERALISATION FILTER cartridges, follow the instructions hereafter.

CONTACT HAZARD	
Contact with eyes.	Irritating to eyes (R36).
Contact with skin.	Lightly irritating to skin.
FIRST-AID MEASURES	
Contact with eyes.	Rinse immediately with plenty of water and remove all particles.
Contact with skin.	Take off contaminated clothing.
	Remove all particles and rinse affected areas with water.
ACCIDENTAL DISPERSION MEASURES	
Precautions for people.	Keep people away.
	Pay attention to avoid falling on the slippery floor.
Decontamination methods.	Collect the product and place it in suitable plastic containers for recycling or disposal, according to the indicated provisions.
NOTES FOR WASTE DISPOSAL	
The used product is a special non-hazardous waste.	
The product must be disposed of according to the local, regional or national laws in force.	
The CER number for saturated or exhausted ion-exchange resins used to prepare drinkable water or water for industrial use is: 190905	

5.3.2. FIRST INSTALLATION OF THE DEMINERALISATION FILTER INSIDE THE TANK

Extract the INTEGRATED DEMINERALISATION FILTER from its package, then proceed as follows:

1. Empty the water tank, if equipped, through the special pipe;
2. Remove the upper panel by turning the lock (A) anti-clockwise and then lifting it from the appropriate side grips;
3. Fit fitting (1) into the seat (2) at the bottom of the sterilizer's tank and exert a slight pressure;

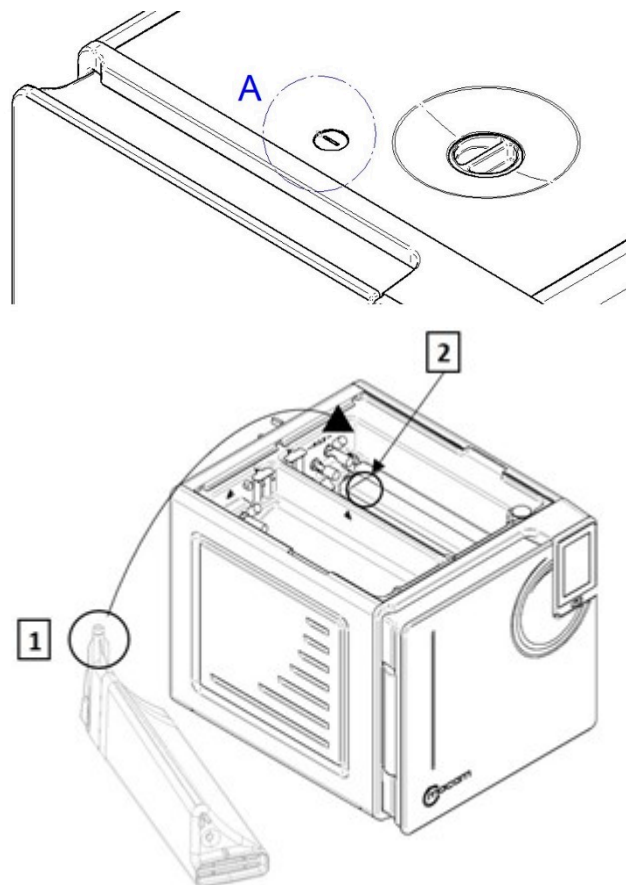

4. Push the rear part of the demineraliser downwards until it reaches the stop with the rear tab of the filter;
5. Turn the locking lever, located in the load tank, until it reaches the top of the filter;
6. Fill the tank with water from the mains;
7. Position the upper panel and turn the lock A clockwise;
8. The sterilizer is ready for use.

5.3.3. PRECAUTIONS TO AVOID WATER STAGNATION

When it is not used for long periods, the load tank must be emptied.

 **Failure to empty the integrated demineralisation filter will cause the deterioration of water quality and favour bacterial growth due to water stagnation inside demineralisation filter pipes and sterilizer tanks.**

5.3.4. TECHNICAL SPECIFICATIONS OF THE DEMINERALISATION FILTER

Operating temperature	+15°C ÷ +35°C
Storage temperature	+5°C ÷ +30°C
Cartridge weight	1.2 kg
Use	Internal
Inlet water	Mains drinkable water
Outlet water quality	Conductivity < 15µS/cm
Demineralised water production	Approx. 110 litres

Conductivity µS/cm	Sterilization cycles		
	17l	22l	28l
300	350	260	250
400	280	210	200
500	230	170	160
600	190	140	135
700	150	110	100
800	115	95	85
900	100	75	70
1000	70	50	45

- A Demineralisation filter consumption
- B Sterilization cycles*
- C Conductivity µS/cm

* the number of cycles has been calculated on an average load of unwrapped solid material for each model

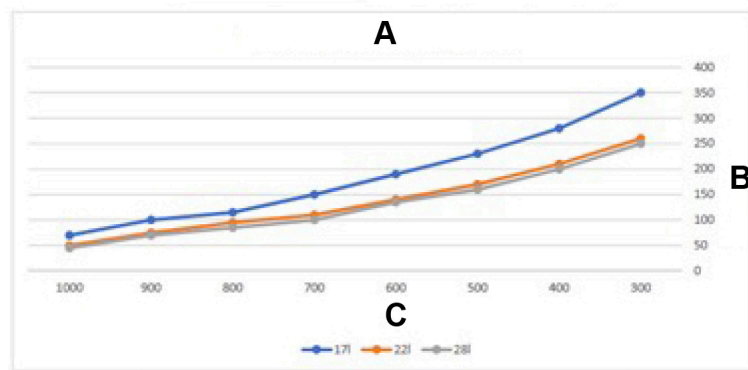

5.4. MAINTENANCE OF THE INTEGRATED DEMINERALISATION FILTER

 | The integrated demineralisation filter is a consumable part; a message is displayed when it must be replaced (see alarm code table).

For replacement, see chapter DESCRIPTION OF MAINTENANCE OPERATIONS, section CLEANING AND DISINFECTION OF WATER FILTERS AND TANKS.

 | If the autoclave is to be used with distilled water, remove the integrated demineralisation filter from the load tank.

5.5. DISTILLED WATER FILLING

The sterilizer is equipped with a demineralisation filter fitted inside the filling tank, which allows supplying the device with standard water from the mains. The quality of the water treated by the integrated filter is checked automatically through a conductivity sensor.

If the integrated demineralisation filter is not present, ONLY use demineralised/distilled water having the following characteristics to supply the sterilizer.

DESCRIPTION	VALUES IN THE WATER SUPPLY	VALUES INSIDE RESIDUAL
DRY CONDENSATE	< 10 mg/l	< 1 mg/l
SILICON OXIDE SiO ₂	< 1 mg/l	< 0.1 mg/l
IRON	< 0.2 mg/l	< 0.1 mg/l
CADMIUM	< 0.005 mg/l	< 0.005 mg/l
LEAD	< 0.05 mg/l	< 0.05 mg/l
HEAVY METAL RESIDUES (iron, cadmium and lead excluded)	< 0.1 mg/l	< 0.1 mg/l
CHLORIDES	< 2 mg/l	< 0.1 mg/l
PHOSPHATES	< 0.5 mg/l	< 0.1 mg/l
CONDUCTIVITY AT 20°C	< 15 µS/cm	< 3 µS/cm
pH	5 - 7	5 - 7
ASPECT	colourless, transparent, without sediment	colourless, transparent, without sediment
HARDNESS	< 0.02 mmol/l	< 0.02 mmol/l

5.5.1. MANUAL FILLING

Upon the first use of the sterilizer and whenever a water shortage is signalled, fill or top up the water load tank.

Open the filling plug.

Pour water through the funnel until reaching the maximum level inside the tank (MAX). When the (MAX) level is reached, the sterilizer will make a sound indicating that the correct water level has been reached. Then stop filling and close the plug.

Pay attention not to spill water on the machine; in case, promptly dry.

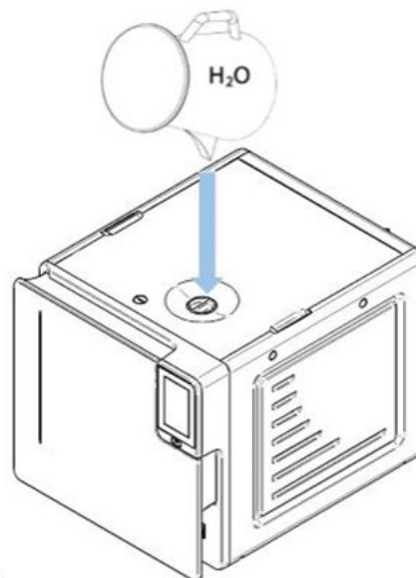

**The tank must be filled before the cycle starts or after its completion.
Do not open the tank doors during the cycle execution in order to prevent hot water leaks.**

5.5.2. AUTOMATIC FILLING

Refer to the "ADDITIONAL COMPONENTS" appendix.



*If an automatic filling system is connected (EV AUX, PURE 100 / 500 kit and external pump kit), the direct discharge connection must be used.
In case of fault or failure, this system allows any excess water produced by the automatic filling system to flow into the centralized draining point, thus preventing flooding.*

6. CONFIGURATION

The sterilizers offer a wide range of customizable options. The user can thus configure the device according to his/her own needs, adapting the performance based on, for example, the type of activity carried out, the type of material to be sterilized and the frequency of use. Using the configuration program, the user can set a series of options available in user-friendly menus.

 Use the configuration program whenever necessary.
A correct customisation of the device provides the best performance and the most satisfactory use.
The technical service department (see appendix) is available to help users by providing suggestions or advices on the best way to use the options in the configuration program.

6.1. SETTINGS

To enter the configuration program, select the icon shown on the side.

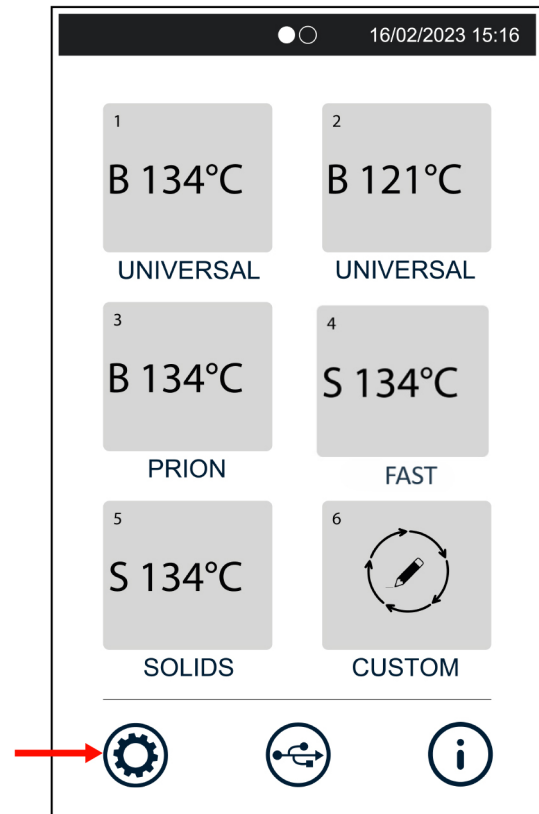

6.1.1. LANGUAGE

Select the LANGUAGE, DATE AND TIME option.

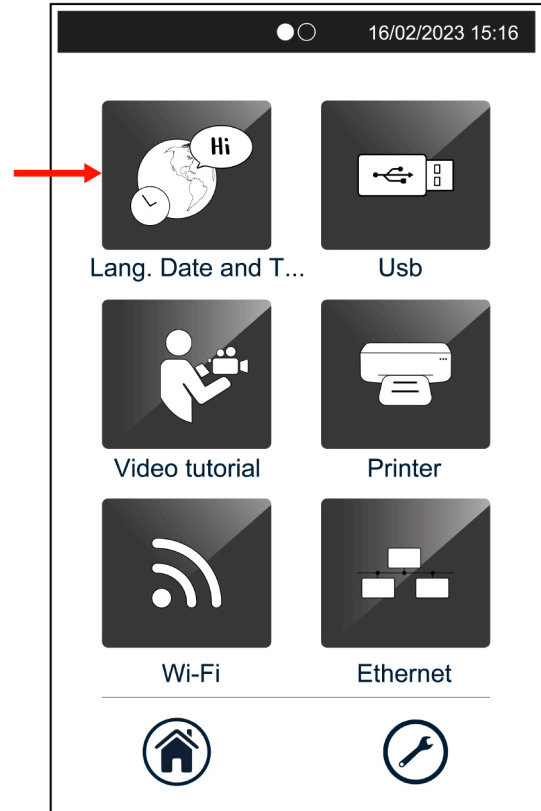

Select the desired language by scrolling the list and confirm by pressing ✓.

Pressing the button corresponding to the EXIT icon returns to the previous menu without saving the changes made.

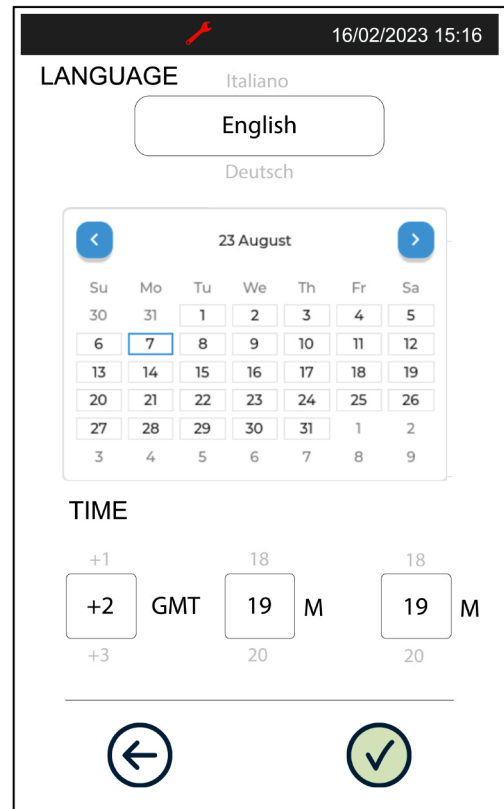

6.1.2. DATE AND TIME

Select the LANGUAGE, DATE AND TIME option.

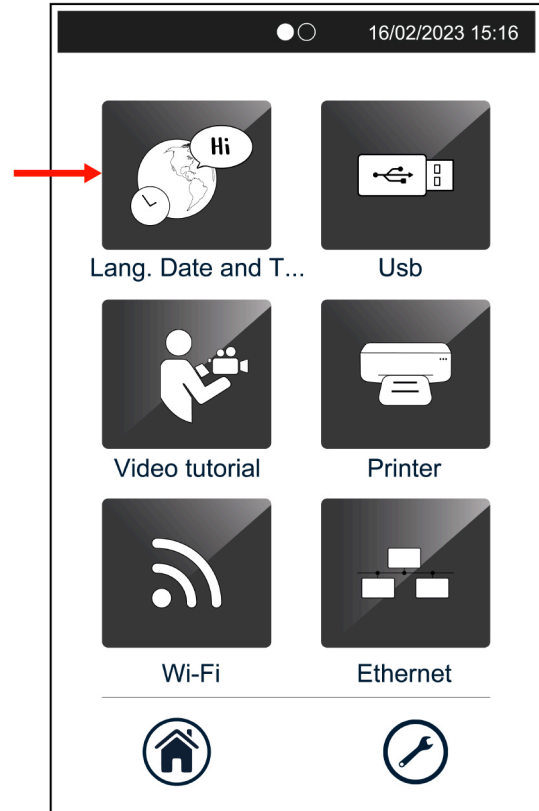

Select the date via the displayed calendar and the desired time by scrolling through the options, confirm by pressing ✓.

Pressing the button corresponding to the EXIT icon returns to the previous menu without saving the changes made.

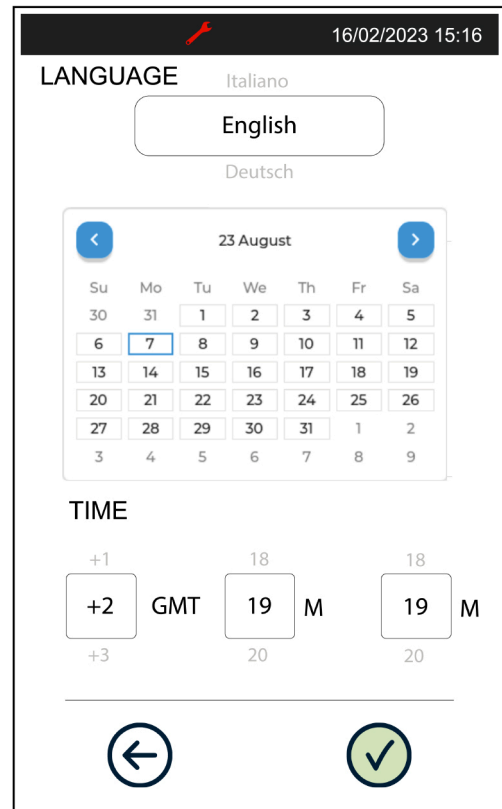

6.1.3. USB

Select the USB option.



Select, among the various options, which cycle reports to download to the USB pendrive.
The NEW item allows you to download cycle reports never downloaded before.

Within the list there is also a CUSTOM MODE item that allows you to define, by cycle intervals, the cycles for which you want to download the report.

Pressing the button corresponding to the EXIT icon returns to the previous menu without saving the changes made.

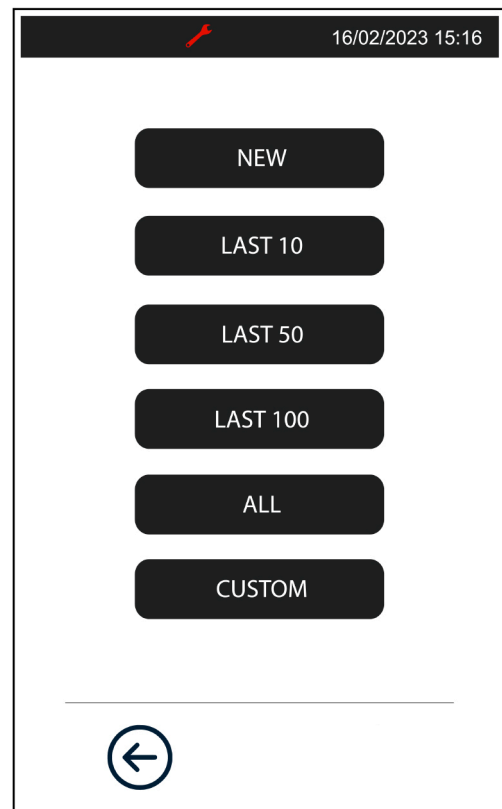

Insert USB key.

Once you confirm the selections of cycle reports, the download screen will appear with its progress.

Pressing the button corresponding to the EXIT icon returns to the previous menu stopping the download.

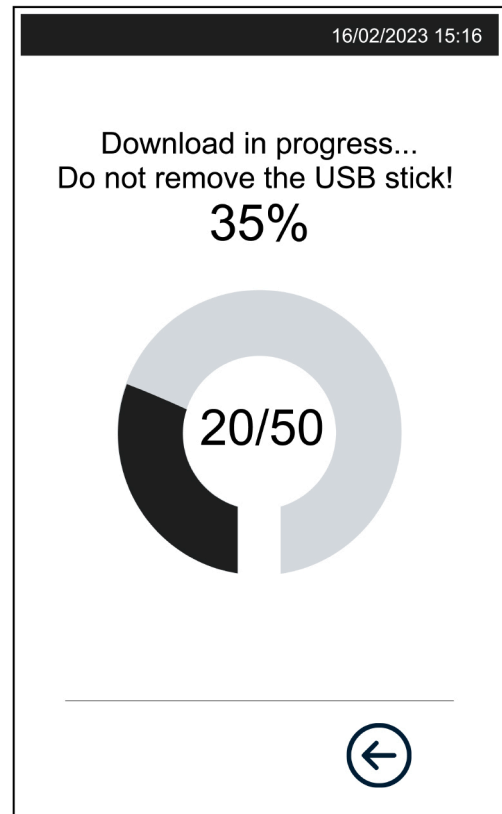

6.1.4. VIDEO TUTORIAL

Select the VIDEO TUTORIAL option.

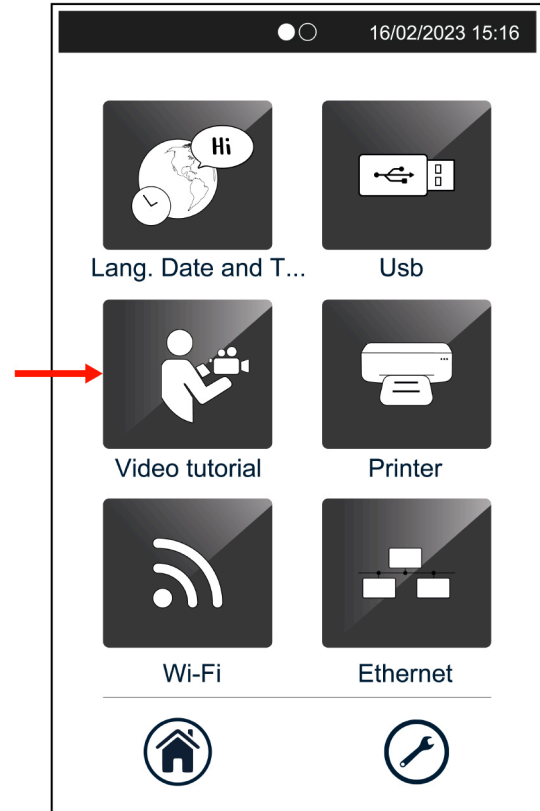

This section lists a series of instructional videos on the use of the device.

You can navigate the screen by scrolling or by using the vertical scroll bar on the right side, and play the desired video by pressing the relevant button.

Pressing the button corresponding to the EXIT icon returns to the previous menu.

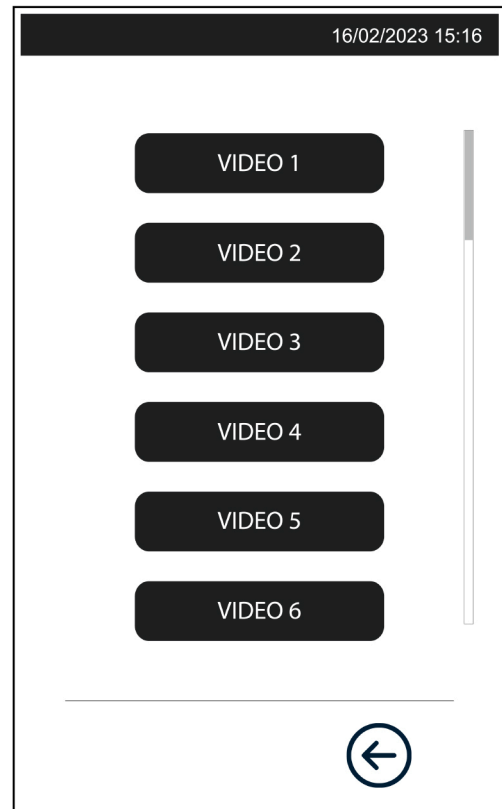

6.1.5. PRINTERS

Select the PRINTER option.

Selecting the print format

To set the desired print format, select the corresponding button on the right side of the screen (REPORT; EXTENDED REPORT, BARCODE and QR CODE). The symbol **A** defines the selection set.

Selections BARCODE and QR CODE refer to label printing, while REPORT and EXTENDED REPORT refer to cycle report printing on thermal paper.

- Pressing the ✓ icon sets automatic printing at the end of each cycle;
- Pressing the appropriate icon with the printer will print the last cycle performed.

Select the **BARCODE** or **QR CODE** icon to set such printing mode.

In this configuration, the Labels screen is accessed at the end of each sterilization cycle or during the label printing phase of the last cycle performed. On this screen, you will be asked to scroll down and select the following options:

- The number of labels to be printed;
- The days until the expiry of the sterilized bags.



Selecting and activating the printer by means of the "SHARE PRINTER" function

Use the drop-down menu, to select OFF if you do not wish to use the printing functions.

Use the same drop-down menu on the left side of the screen to select the desired printer:

- **SERIAL PRINTER:** the printer used will be the printer connected to the sterilizer via a serial cable;
- **REMOTE PRINTER:** the sterilizers enabled to share the printer (which can be recognised by their serial number) will be displayed and can be selected.

By selecting an autoclave from the list, the report(s) or label(s) can be printed using the serial printer physically connected to it.

If the autoclave on which you want to print remotely is not listed, you can select it by manually entering its IP address (which can be accessed on the info screen). By clicking **B**, you can customise the name of the selected remote printer.

In order to use the printer sharing feature, the following requirements must be met:

- The sterilizer to which the printer is connected via a serial cable must be set to ON for the SHARE PRINTER item on the screen;
- The sterilizers must be connected to the same network via Wi-Fi or Ethernet.

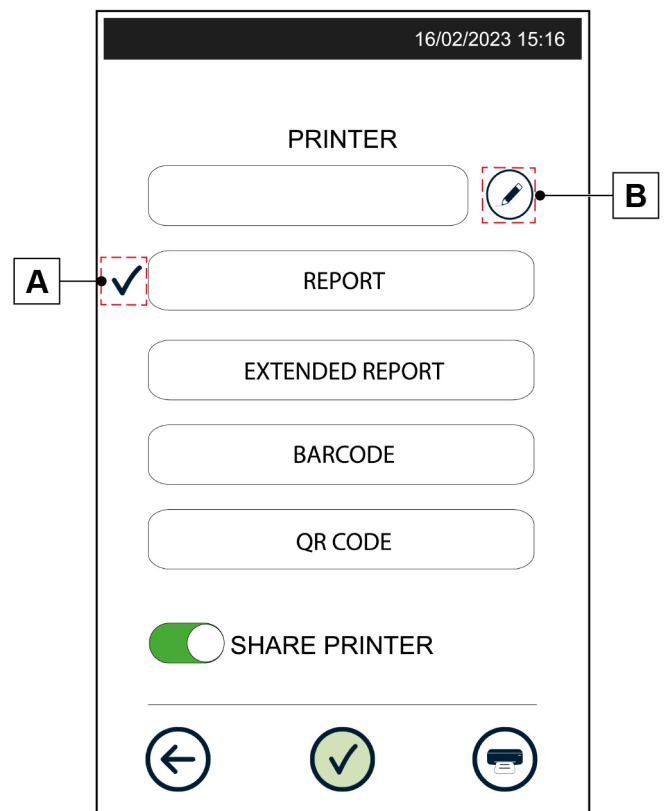

To enable/disable the "SHARE PRINTER" function:

SHARE PRINTER ON



In this condition, the sterilizer is enabled to be used as a remote printer; the sterilizer will then be available to receive prints from other autoclaves connected to the same network.

SHARE PRINTER OFF



On the other hand, in this condition, the autoclave will not be available to receive prints from other autoclaves connected to the same network. Pressing the button corresponding to the EXIT icon returns to the previous screen without saving the changes made.

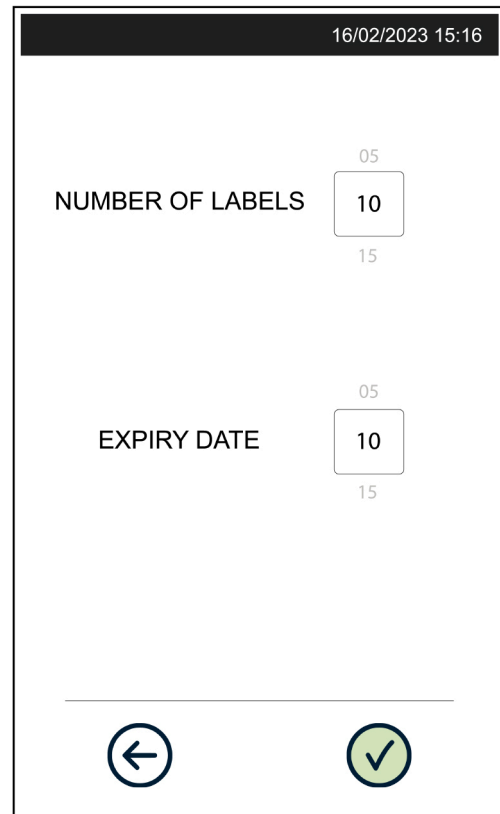

6.1.6. WI-FI

Select the WI-FI option.

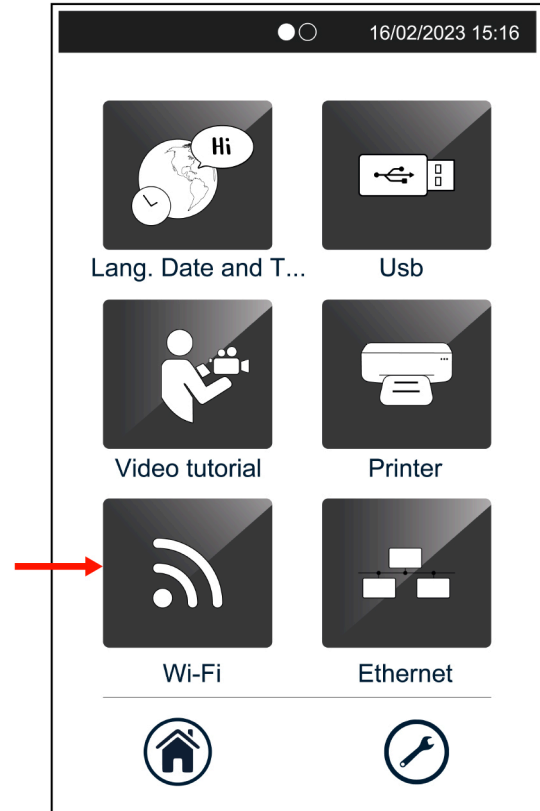

Use the relevant icon to select whether the WI-FI connection is to be enabled or not.

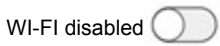
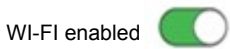

The machine will automatically detect available networks (networks marked with the padlock symbol require a password).

Select the network you want to access.

The symbol (A) defines the network to which you are connected.

Confirm your selection with the ✓ icon.

Pressing the button corresponding to the EXIT icon returns to the previous menu without saving the changes made.

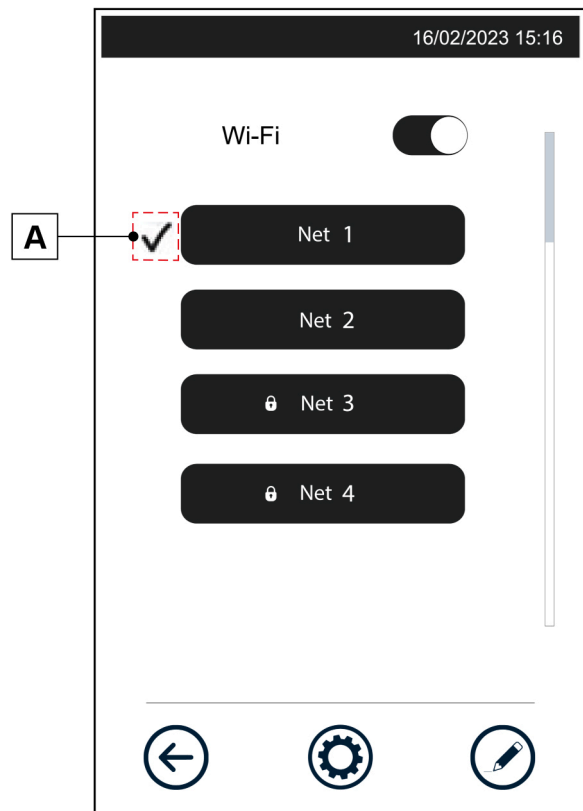

Enter the WI-FI password.

- B** for alphabetic characters
- C** for uppercase/lowercase
- D** for numeric characters and symbols
- E** to delete the last character
- F** show/hide password

Confirm the entered password with the ✓ icon.

Pressing the button corresponding to the EXIT icon returns to the previous screen without saving the changes made.

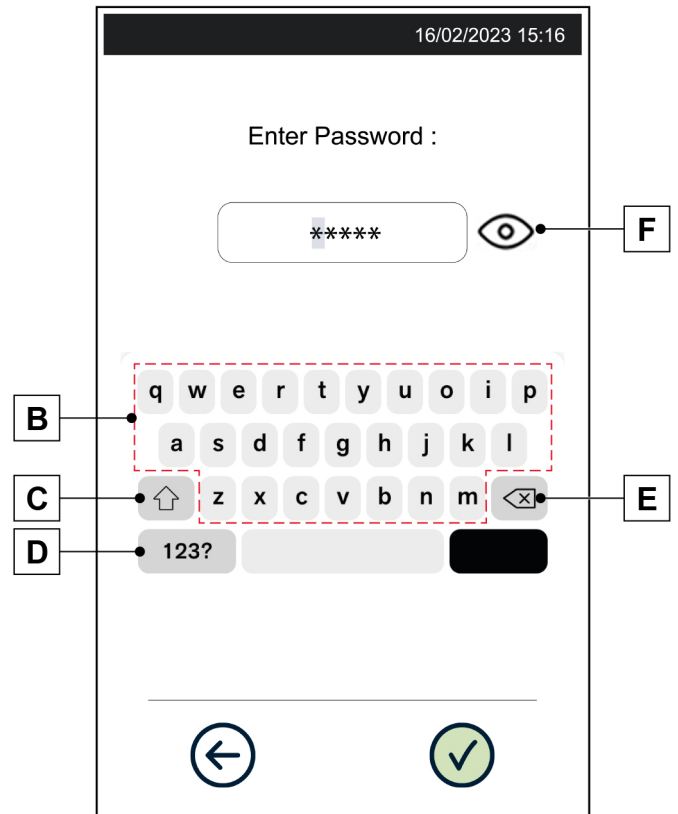

If the desired network does not appear in the list, it can be searched using the appropriate icon on the right.

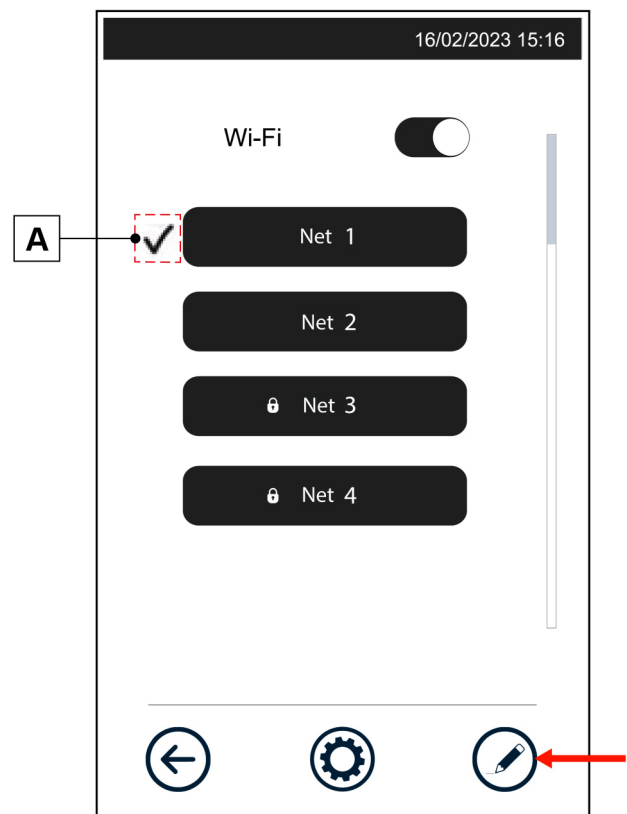

Manually enter the **SSO** and the password (**PSW**) of the network you want to access, selecting the relevant text boxes.

Confirm the entry with the ✓ icon.

The desired network will now appear in the previous screen (network list) with the symbol (A) (connected).

Pressing the button corresponding to the EXIT icon returns to the previous screen without saving the changes made.



By selecting the gears icon, you can change the parameters of the network to which you are connected.

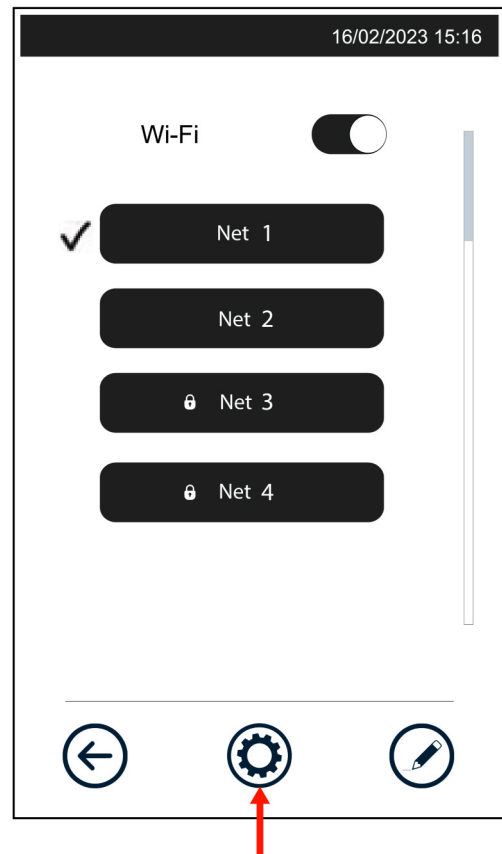

Select between the manual or automatic management of the DHCP.

In the case of manual DHCP, by pressing the blue values you can change the values of: **IP**, **MASK**, **GATE** and **DNS** (next screen).

Confirm your selections with the ✓ icon.

Pressing the button corresponding to the EXIT icon returns to the previous menu without saving the changes made.

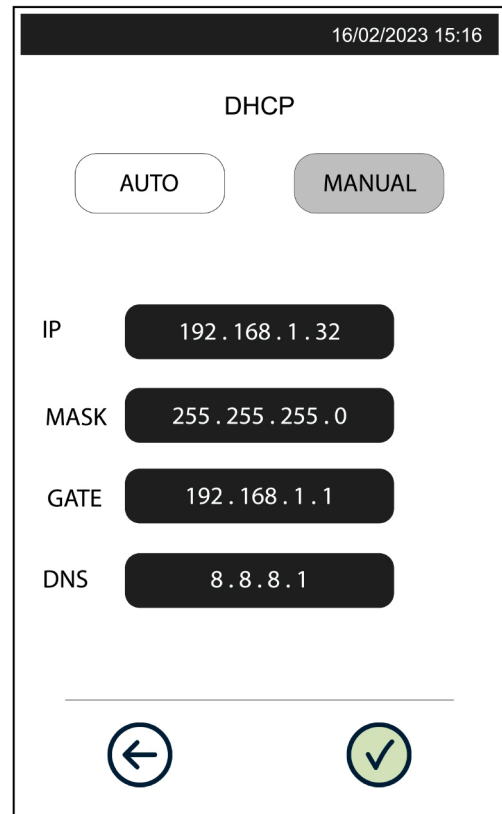





Enter the desired value:

- B** for numeric characters
- C** to delete character

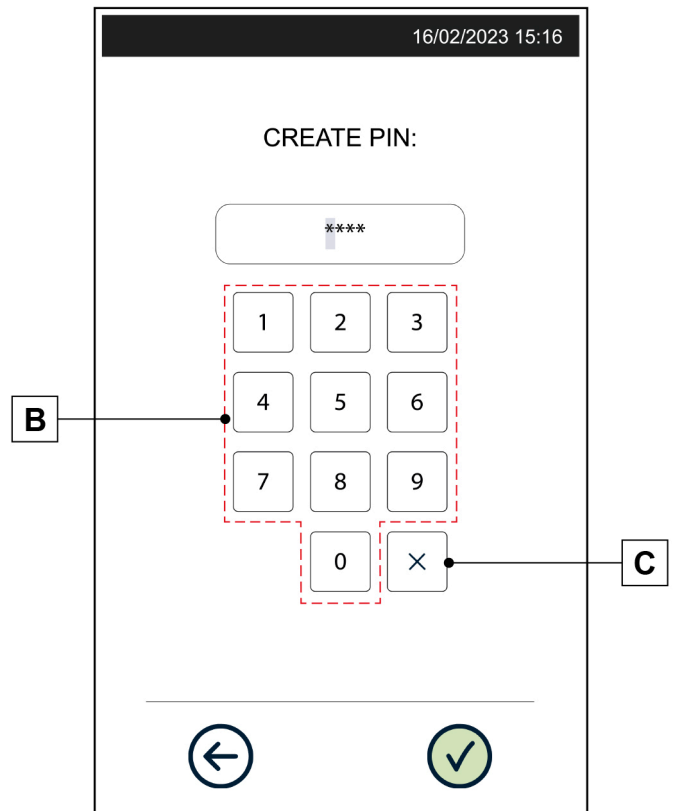
Confirm the entry with the ✓ icon.

Pressing the button corresponding to the EXIT icon returns to the previous screen without saving the changes made.



-  According to DHCP server configuration the numbering received may change at each start.
-  The TCP-IP number assigned to the sterilizer appears in the Ethernet or Wi-Fi setting screen.
-  It is usually possible to set DHCP server in order to always assign the same IP number to a given device or to assign the same number to a given device for a predetermined period of time.
For these settings refer to the instruction manuals of your DHCP server or of the local network Internet router.
These settings may require the "MAC address" of the sterilizer, for this information it is necessary to contact the technical service.

6.1.7. ETHERNET

Select the ETHERNET option.

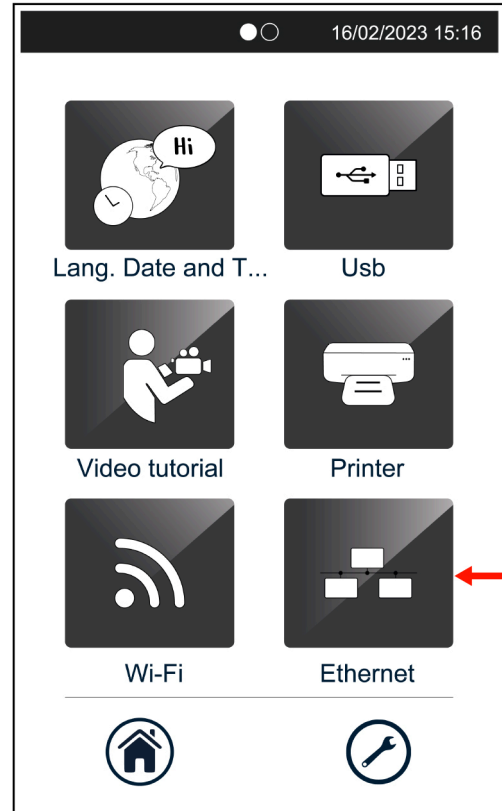

Select between the manual or automatic management of the DHCP.

In the case of manual DHCP, by pressing the blue values you can change the values of: **IP**, **MASK**, **GATE** and **DNS** (next screen).

Confirm your selections with the ✓ icon.

Pressing the button corresponding to the EXIT icon returns to the previous menu without saving the changes made.

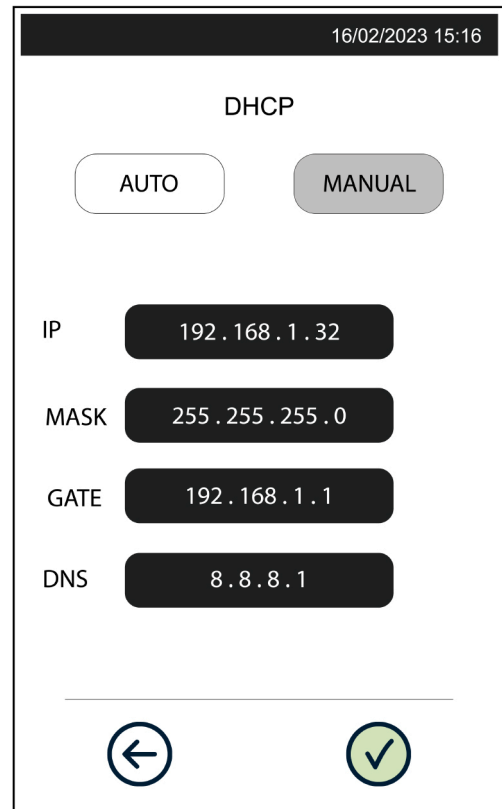





Enter the desired values using the numeric keypad:

- B** for numeric characters
- C** to delete the last character

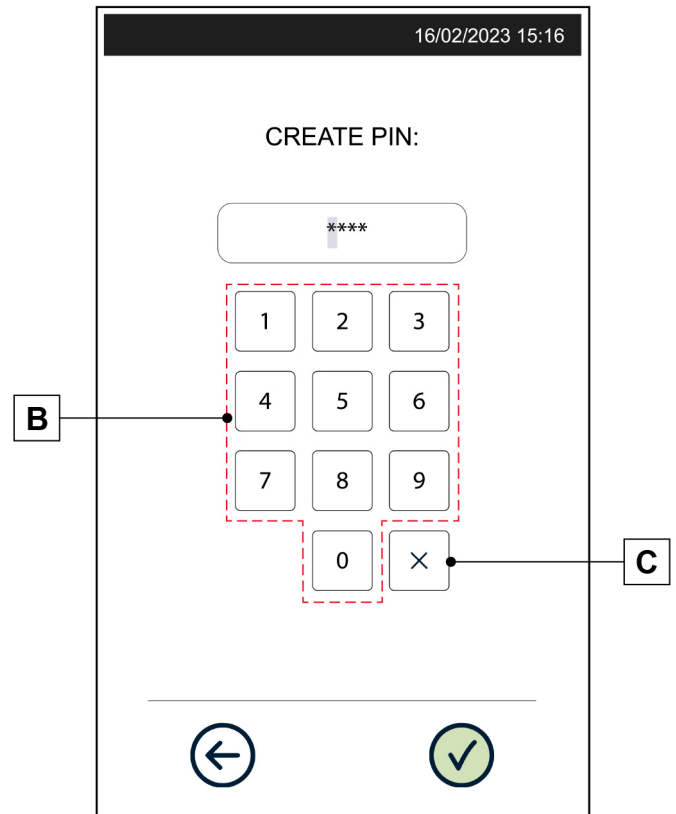
Confirm the entry with the ✓ icon.

Pressing the button corresponding to the EXIT icon returns to the previous screen without saving the changes made.



-  According to DHCP server configuration the numbering received may change at each start.
-  The TCP-IP number assigned to the sterilizer appears in the Ethernet or Wi-Fi setting screen.
-  It is usually possible to set DHCP server in order to always assign the same IP number to a given device or to assign the same number to a given device for a predetermined period of time.
For these settings refer to the instruction manuals of your DHCP server or of the local network Internet router.
These settings may require the "MAC address" of the sterilizer, for this information it is necessary to contact the technical service.

6.1.8. USERS

Select the USERS option.

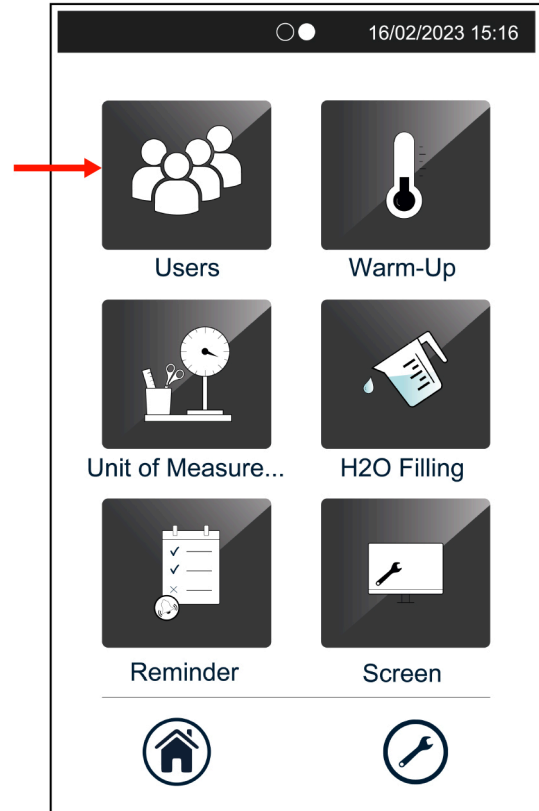

6.1.8.1. CREATING THE FIRST USER

The first selection of the USERS menu requires the entry of a new User who will also acquire administrator credentials.

Use the alphanumeric keypad to enter the user name of the new user:

- A** for alphabetic characters
- B** for uppercase/lowercase
- C** for numeric characters and symbols
- D** to delete the last character

Confirm the entered user name with the ✓ icon.

Pressing the button corresponding to the EXIT icon returns to the previous screen without saving the changes made.

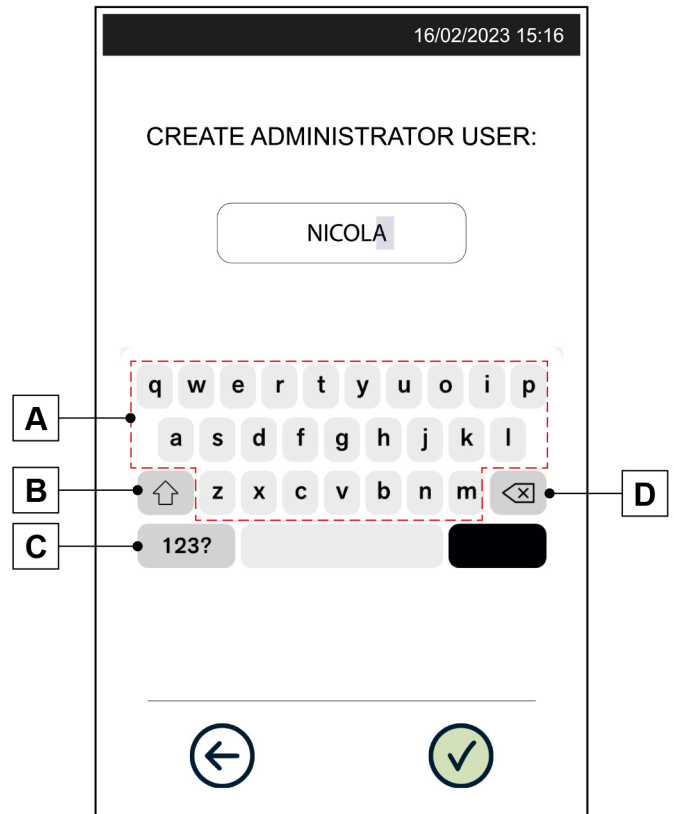

Enter the PIN of the first User (each user has his/her own PIN).

- A** for numeric characters
- B** to delete the last character

Confirm the entry with the ✓ icon.

Pressing the button corresponding to the EXIT icon returns to the previous screen without saving the changes made.

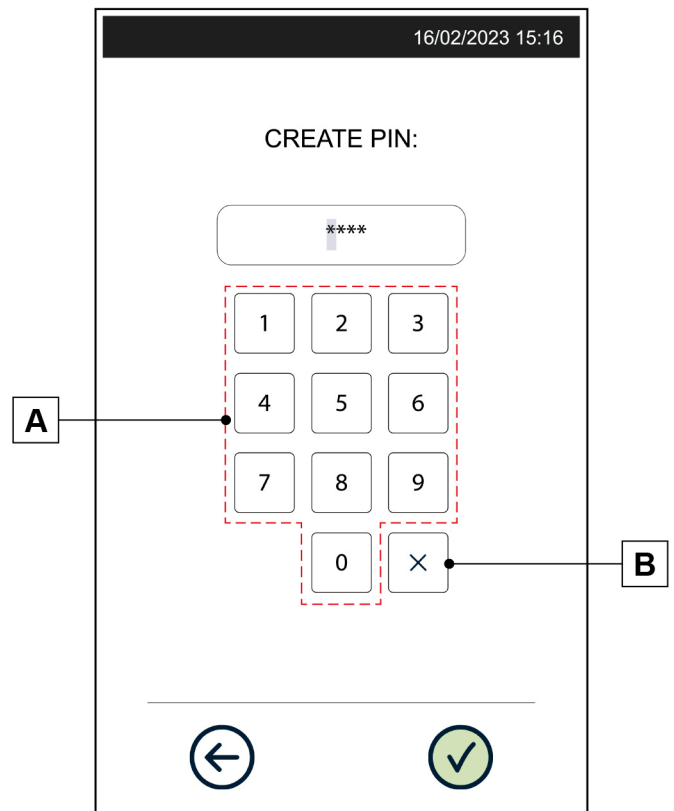

When the first user is created, he/she is shown in the section with the list of registered users.

Administrator users are identified with the * symbol.

To navigate the list, use the sidebar or scroll.

Pressing the button corresponding to the EXIT icon returns to the previous screen.

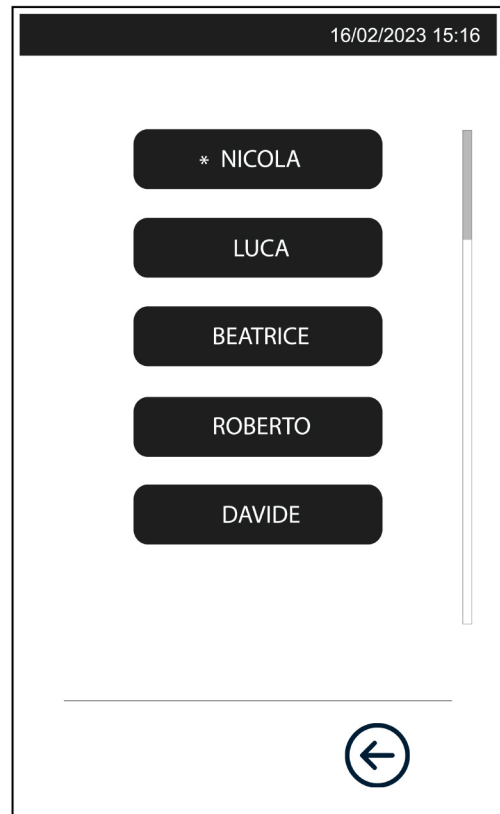

6.1.8.2. CREATING THE USER (OPERATION AVAILABLE ONLY FOR ADMINISTRATOR USER)

Select the administrator user and enter the relevant PIN.

Pressing the button corresponding to the EXIT icon returns to the previous screen.



Select USERS LIST.

Pressing the button corresponding to the EXIT icon returns to the previous screen.

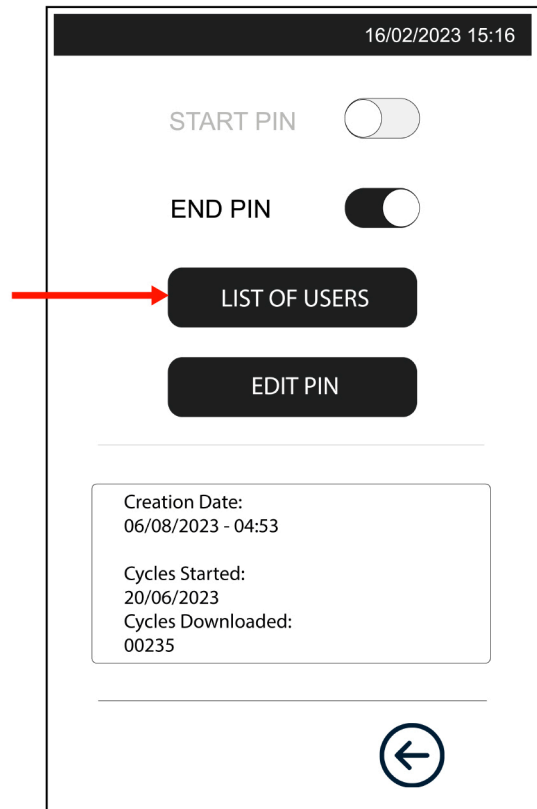

A screen similar to the main users menu appears, with the difference that there is an icon to the bottom right that allows you to add a new user to the list.

Select the above icon and, as for the creation of the first user (see paragraph CREATING THE FIRST USER), enter the name and pin.

Pressing the button corresponding to the EXIT icon returns to the previous screen.

 | *A maximum of 30 users can be entered.*



6.1.8.3. USER MANAGEMENT (OPERATION AVAILABLE ONLY FOR ADMINISTRATOR USER)

Select an administrator user and enter the relevant PIN.

Pressing the button corresponding to the EXIT icon returns to the previous screen.



Select USERS LIST.

Pressing the button corresponding to the EXIT icon returns to the previous screen.

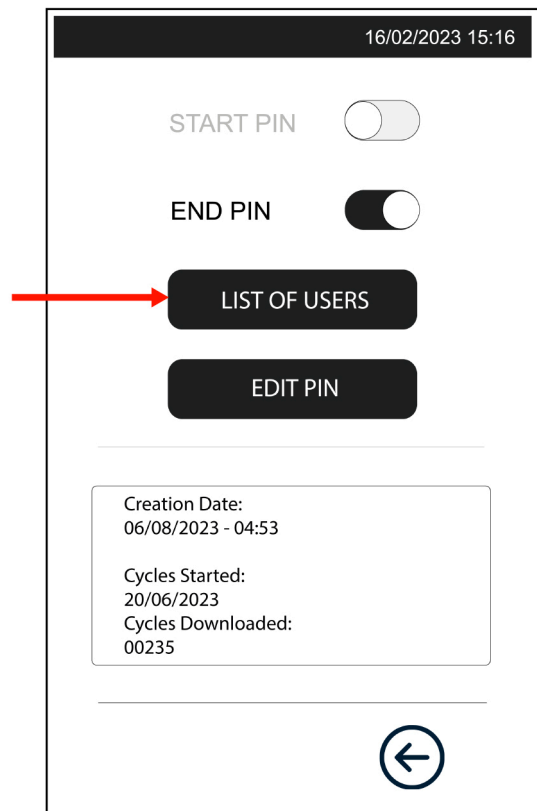

Select the user you want to edit/manage (also administrator).

Pressing the button corresponding to the EXIT icon returns to the previous screen.



Available options are:

- **MAKE ADMINISTRATOR** - allows you to make a user already on the list an Administrator
- **CYCLES AVAILABLE** - allows you to define the cycles that the user can perform
- **CHANGE PIN** - allows you to change the user's PIN
- **DELETE USER** - allows you to delete the user

Administrator user

Non-administrator user

Selecting **DELETE USER** displays a pop-up prompting you to confirm your selection.

At the bottom of the screen is the information of the selected user.

Pressing the button corresponding to the EXIT icon returns to the previous screen.

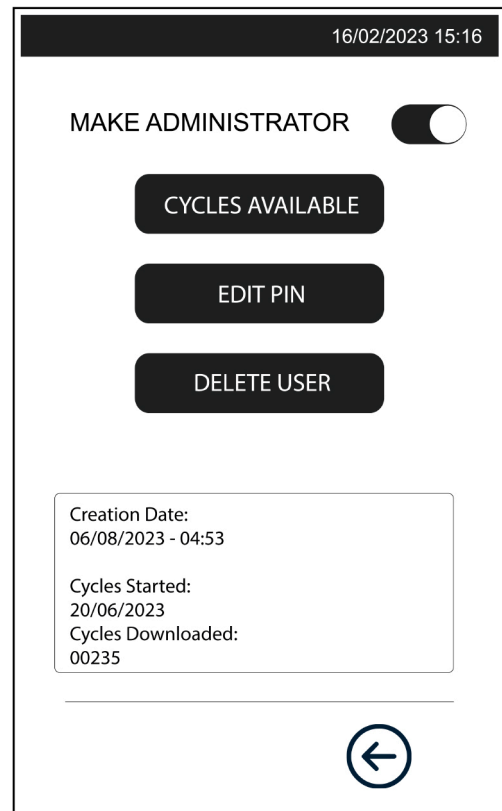

 If you are the only administrator user, you cannot delete yourself/make yourself non-administrator.

 In the case of administrator, CHANGE PIN and INFO options are also available in the main screen of administrator user (USERS → ADMINISTRATOR USER SELECTION → CHANGE PIN / INFO)

Selecting **CYCLES AVAILABLE** displays the following screen.

Select the cycles that you want to make available to the selected user.

The selected cycles will become coloured.

Confirm your selections with the ✓ icon.

Pressing the button corresponding to the EXIT icon returns to the previous screen without saving the changes made.

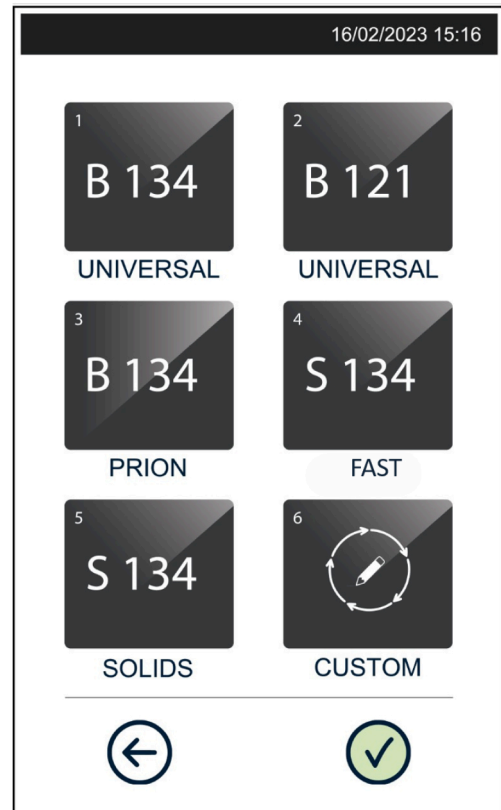

Selecting **CHANGE PIN** will show the PIN entry screen already seen.

Enter the new PIN.

- A** for numeric characters
- B** to delete the last character

Confirm the entry with the ✓ icon.

Pressing the button corresponding to the EXIT icon returns to the previous screen without saving the changes made.

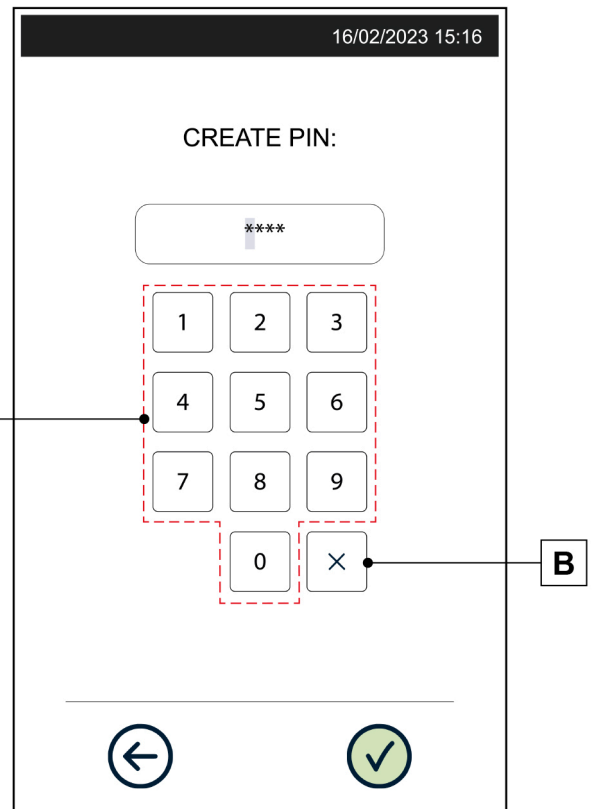

*If the user enters an incorrect pin for 3 times, at the following pin entering request it is necessary to enter the specific unlock pin (see APPENDIX – USER PIN RESET) indicated at the end of the manual.
The subsequent user menu access is like the first access.*

6.1.8.4. ENABLING THE USER IDENTIFICATION AT THE START AND END OF THE CYCLE (FUNCTION ONLY AVAILABLE TO ADMINISTRATOR USER)

Select an administrator user and enter the relevant PIN.

Pressing the button corresponding to the EXIT icon returns to the previous screen.

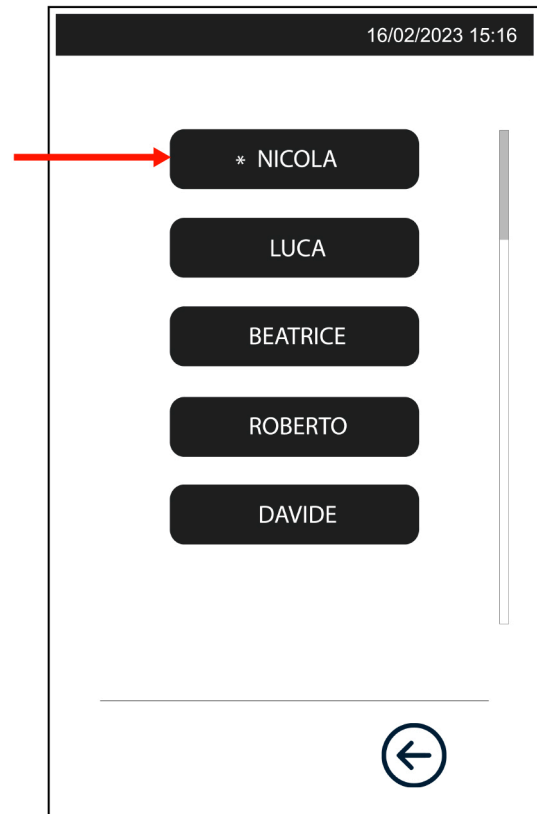

Using the appropriate icons, you can define if the machine has to:

- Request the PIN at the start of each cycle (PIN START)
- Request the PIN at the end of each cycle (PIN END)

Option active 

Option disabled 

Pressing the button corresponding to the EXIT icon returns to the previous screen.

 | *The selection made is valid for all users.*

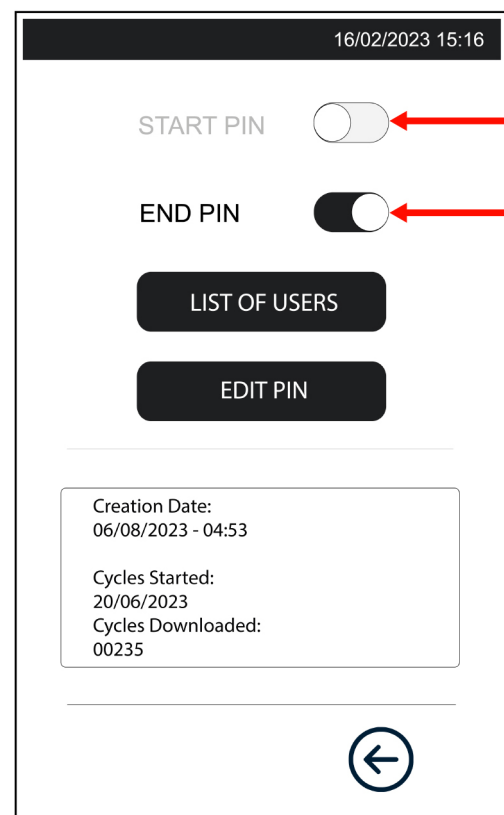

6.1.8.5. USER MANAGEMENT (NON-ADMINISTRATORS)

Select a non-administrator user and enter the relevant PIN.

Pressing the button corresponding to the EXIT icon returns to the previous screen.



From this screen you can:

- View the available cycles by selecting **CYCLES AVAILABLE**
- Change the pin by selecting **CHANGE PIN**
- View the user's information (at the bottom).

Pressing the button corresponding to the EXIT icon returns to the previous screen.



The non-administrator user cannot change the available cycles.

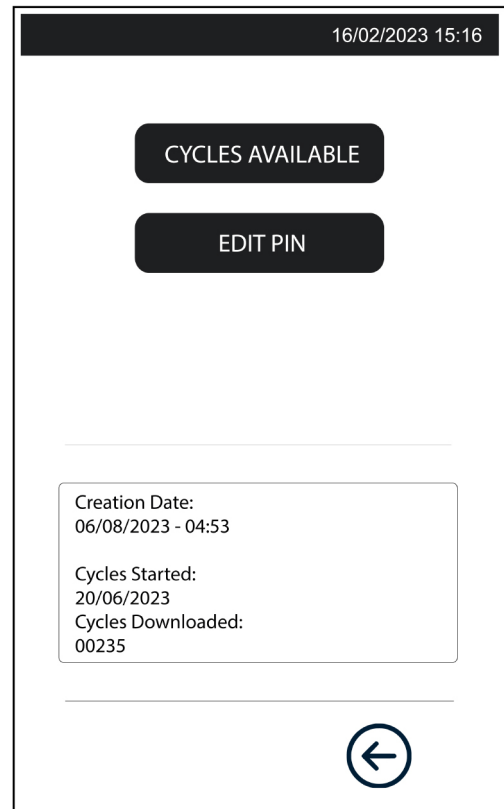

6.1.9. PREHEATING

Select the PREHEATING option.

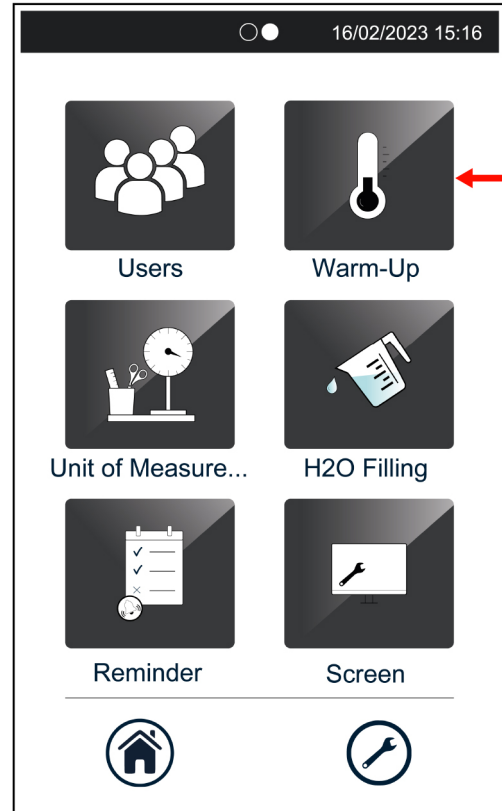

Using the appropriate icons, select if preheating is to be activated with fixed time or time slot mode.

Option active



Option disabled





- By activating the FIXED TIME option, the minutes of preheating activation time can be changed (from 30 to 120) by scrolling;
- By activating the TIME option, the time slot in which preheating is to be activated can be set by scrolling.

Confirm the entry with the ✓ icon.

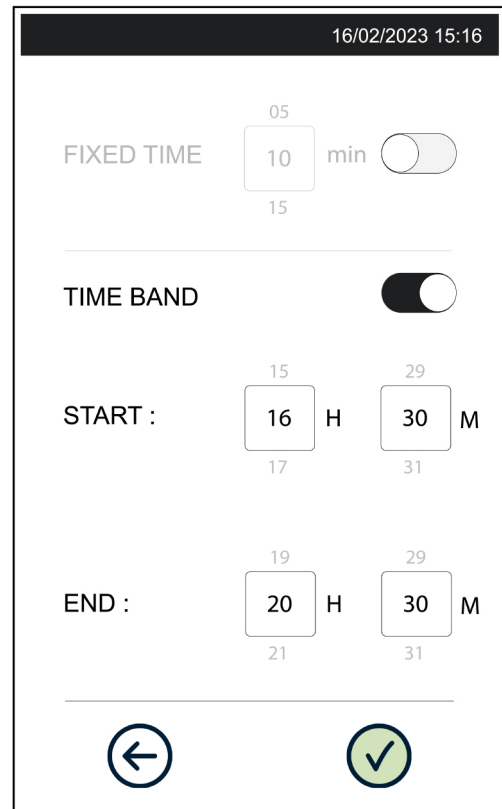
Pressing the button corresponding to the EXIT icon returns to the previous menu without saving the changes made.



-  *Interval minutes should be set according to the number of cycles that are planned in one day.
The set time approximately corresponds to the pause between one cycle and the other.
In this way, the device stays warm and heating time is reduced.*

-  *Preheating is only activated after completion of the first sterilization cycle or test, even if the cycle has failed, unless it is a Vacuum Test. This allows running a Vacuum Test as first cycle when the device is turned on and repeat it if it does not succeed.*

6.1.10. UNITS OF MEASUREMENT

Select the UNITS OF MEASUREMENT option.

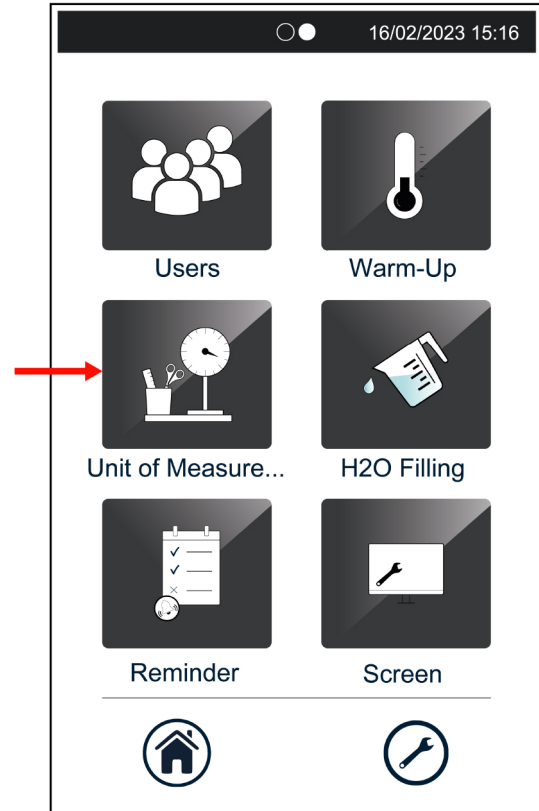

Select the desired units of measurement by pressing the relevant keys.

- PRESSURE: bar or kPa
- TEMPERATURE: °C or °F
- DATE: d/m/y or m/d/y
- TIME: 24h or 12h

Confirm the entry with the ✓ icon.

Pressing the button corresponding to the EXIT icon returns to the previous menu without saving the changes made.

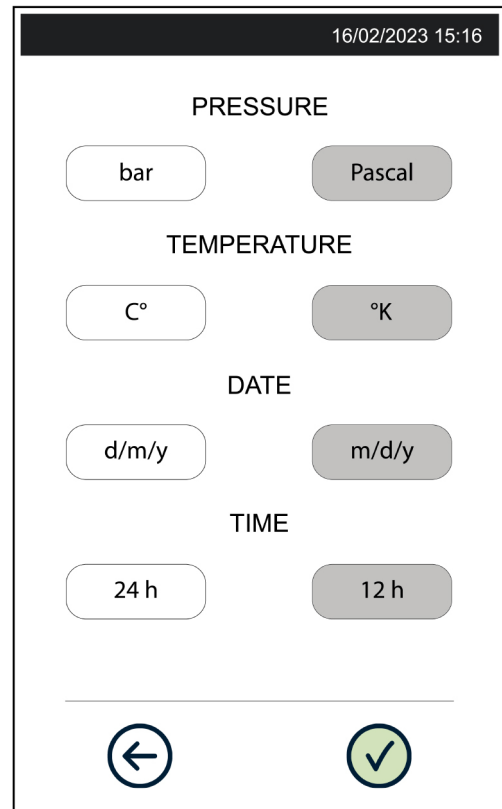

6.1.11. REMINDER

Select the REMINDER option.

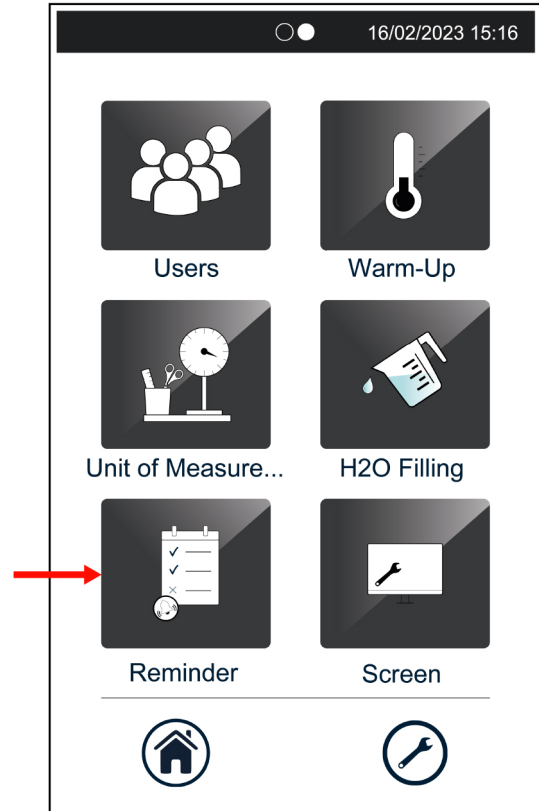

Using the appropriate icons, select whether the cycles for which you want to receive a reminder are activated or not.

- Vacuum Test
- Vacuum + H/B&D
- Helix/B&D

Option active 

Option disabled 

After selecting the cycles, define the reminder frequency:

- DAILY
- WEEKLY
- MONTHLY

Confirm the entry with the ✓ icon.

Pressing the button corresponding to the EXIT icon returns to the previous menu without saving the changes made.

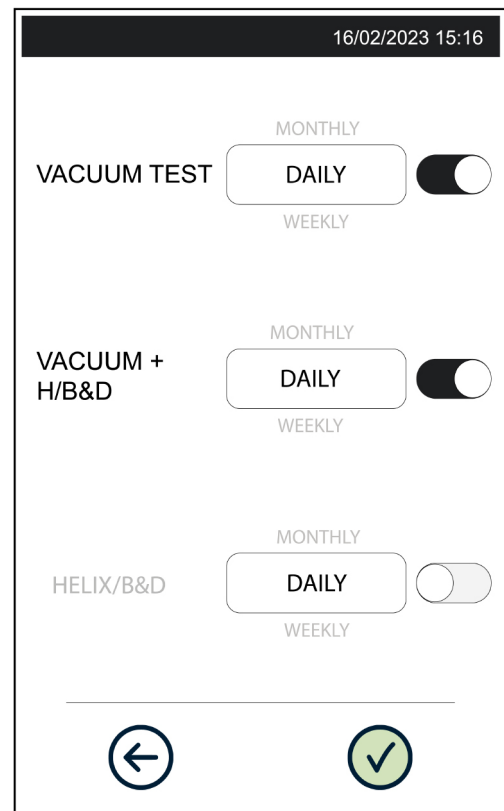

6.1.12. (AUTOMATIC) H2O FILLING

Select the H₂O FILLING option.

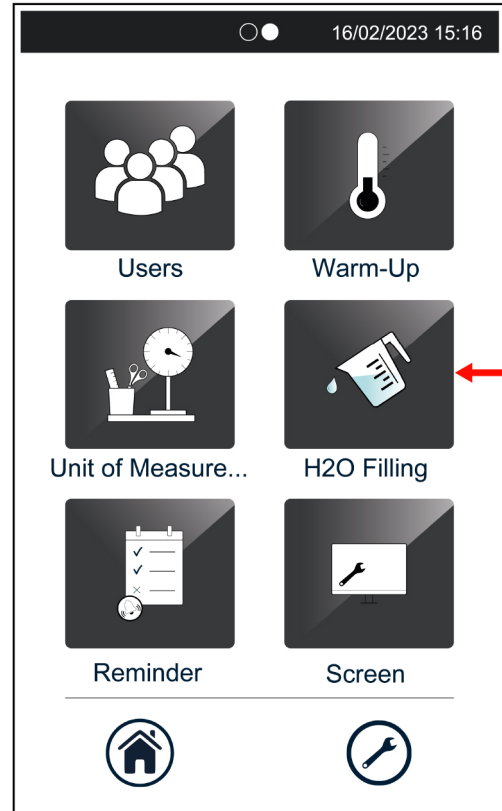

Using the appropriate icon, select whether the automatic water filling, connected to the device, is to be enabled or not.

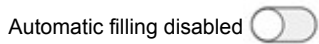
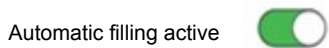



Select the desired type of automatic filling.

The symbol **(A)** defines the selected type of automatic filling.

Confirm the entry with the ✓ icon.

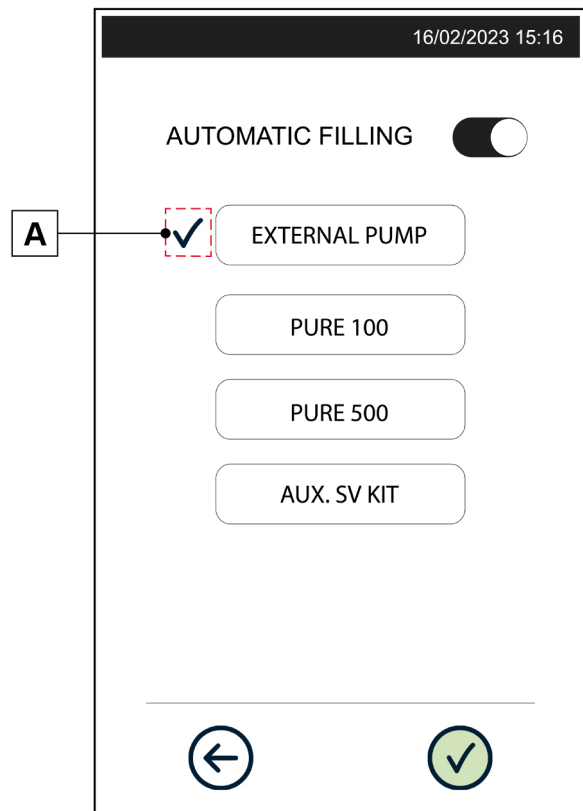
Pressing the button corresponding to the EXIT icon returns to the previous menu without saving the changes made.



-  *When connecting the automatic filling system, the sterilizer asks you to identify the type of device actually connected by pressing the corresponding button.
If connecting the filling system when the sterilizer is off, access the menu via the configuration program and manually select the correct option.*
-  *This menu can also be used to temporarily deactivate the automatic filling system (filters exhausted, fault, etc.) and go to manual tank filling, keeping the automatic filling system connected.*

6.1.13. SCREEN

Select the SCREEN option.

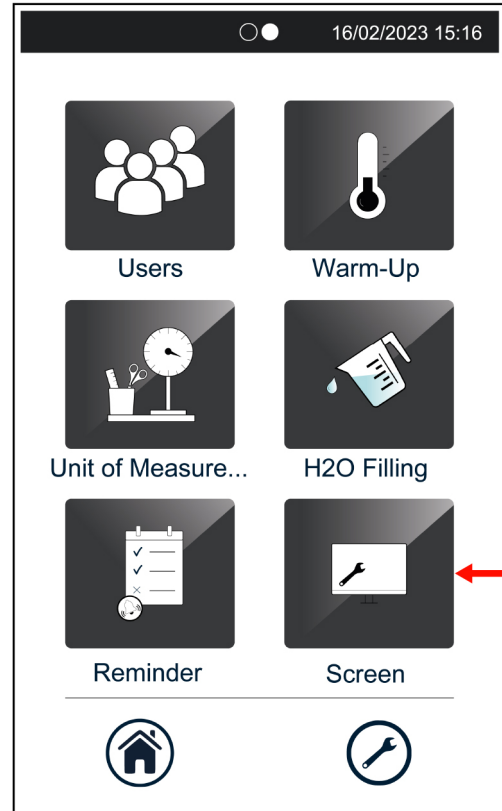

By scrolling, select:

- SCREEN SWITCH-OFF
- BRIGHTNESS
- LED SWITCH-OFF

Confirm the entry with the ✓ icon.

Pressing the button corresponding to the EXIT icon returns to the previous menu without saving the changes made.

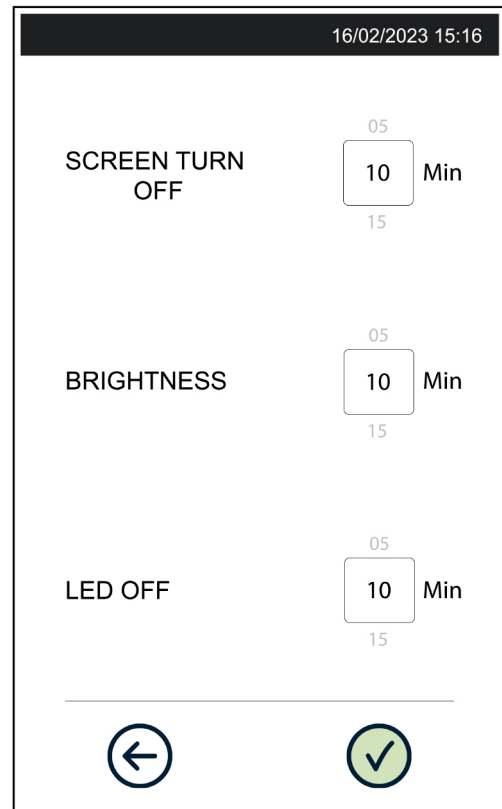

6.1.14. SERVICE

This menu is intended for the technical service department.

It can be used only by an authorised technician.

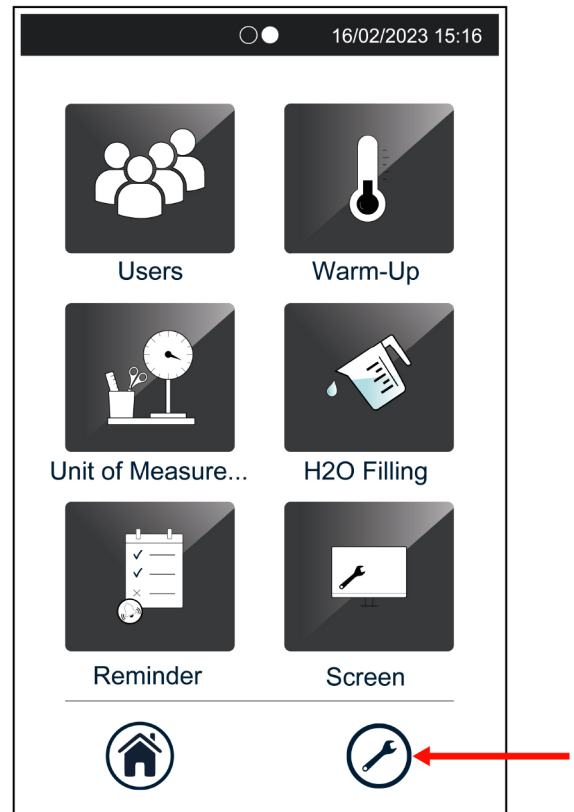

7. PREPARING THE MATERIAL



Always use personal protective equipment.



First of all, it should be recalled that, when handling and managing contaminated material, it is a good idea to take the following precautions:

- Wear rubber gloves of suitable thickness and the specific protective mask on your face;
- Clean your gloved hands with a germicide detergent;
- Always carry the instruments on a tray;
- Never carry them in your hands;
- Protect your hands from contact with any sharp points or edges; this will avoid the risk of contracting a dangerous infection;
- Immediately remove any article that does not need to be sterilized or that is not capable of withstanding the process;
- Carefully wash your still gloved hands when done handling non-sterile material;
- All materials and/or instruments to be sterilized must be perfectly clean, without any type of residue (deposits of organic/inorganic material, fragments of paper, cotton/gauze pads, lime, etc.).

 In addition to causing problems during sterilization, the failure to clean and remove residue can damage the instruments and/or sterilizer itself.

7.1. TREATING THE MATERIAL BEFORE STERILIZATION

An effective cleaning consists of the following:

1. Separate metal instruments by type of material (carbon steel, stainless steel, brass, aluminium, chromium, etc.), to avoid electrolytic oxidation-reduction.
2. Perform a wash using a thermal disinfectant or an ultrasonic device containing a mixture of water and detergent specifically designed for ultrasonic cleaning, carefully following the manufacturer's recommendations.
For best results, use a detergent specifically designed for ultrasound washing.
3. Manual washing is necessary if no dedicated devices are available or when automatic washing is not permitted due to the technical features of the treated material. This technique exposes the operators in charge to higher risks, for this reason it must only be applied when it is strictly necessary.

 Solutions containing phenols or quaternary ammonia compounds can cause corrosion on instruments and on the metal parts of the ultrasound device.

4. After washing, carefully rinse the instruments and make sure that residues have been completely eliminated; if necessary, repeat the washing cycle.
5. Dry all treated instruments. Drying is fundamental because the presence of water traces on the surface can jeopardise the following sterilization process.
The following items can be used for drying:
 - Paper, non-woven fabric or low-particle wipes;
 - Compressed air to dry hollow instruments.
 The operator must wear suitable PPE and protect the working surface to prevent its contamination by any air-dispersed particles.

 To avoid the formation of lime spots, rinse with deionized or distilled water, if possible.
Whenever very hard tap water is used, we recommend always drying the instruments.

For handpieces (turbines, contra angles, etc.), in addition to the procedure described above, perform a cleaning treatment on the special devices ensuring a proper internal cleaning (sometimes including lubrication).

 Before performing the sterilization program, remember to lubricate the internal handpiece mechanisms.
By taking this precaution the instrument life time will not be reduced in any way.



Consult the instructions provided by the manufacturer on the instrument/material to be sterilized before subjecting it to autoclave treatment, checking for any incompatibilities.
Strictly follow instructions for use of detergents or disinfectants and instructions for use of automatic devices for washing and/or lubrication.

As regards textile materials (porous), such as lab coats, napkins, caps and other, carefully wash and dry them before treating them in the autoclave.

 Do not use detergents with a high content of chlorine and/or phosphates. Do not bleach with chlorine-based products. These substances can damage the tray supports, trays and any metal instruments that may be present in the sterilization chamber.

7.2. LOAD ARRANGEMENT



Always use personal protective equipment.



To get the best effectiveness of the sterilization process and preserve the material over time, increasing its useful life, follow the instructions below.

General notes for the positioning on trays:

- Arrange instruments made of different metals (stainless steel, hardened steel, aluminium, etc.) on different trays or anyway on trays well separated from one another.
- In case of instruments not made of stainless steel, put a sterilization paper napkin or a muslin cloth between instrument and tray, avoiding direct contact between the two different materials;
- In any case, arrange the objects sufficiently spaced from each other, so that they can remain in such position for the whole sterilization cycle;
- Make sure that all instruments are sterilized in an open position;
- Position cutting instruments, (scissors, scalpels, etc.) so they can not come into contact with each other during sterilization; if necessary, use a cotton cloth or a gauze to isolate and protect them;
- Arrange recipients (glasses, cups, test tubes, etc.) resting on their side, or upended, thus avoiding pooling water;
- Do not load trays beyond the limit indicated.
- Do not stack trays one on top of the other and do not put them in direct contact with the walls of the sterilization chamber.
- Always use the supplied tray support.
- To insert and remove trays from the sterilization chamber, always use the special supplied extractor.

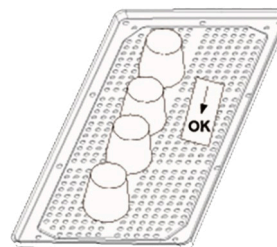

 Place one sterilization chemical indicator per tray to indicate when the process is complete: this will allow avoiding an unnecessary repetition of the process on the same load or, worse, the use of unsterilized material. If packed material is sterilized, place the indicator inside one of the packages.

Note for rubber and plastic hoses:

- Arrange hoses on tray so that their ends are not obstructed or squashed;
- Do not bend or twist hoses, but leave them as linearly stretched as possible.



Notes for packages:

- Arrange packages next to each other, duly spaced and not stacked, avoiding their contact with chamber walls;
- Should it be necessary to wrap special objects, always use a suitable porous material (sterilization paper, muslin napkins, etc.), closing the package with adhesive tape suitable for autoclave.

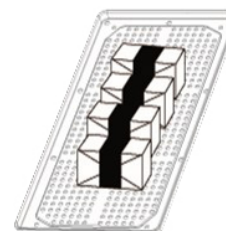

Notes for packed material:

- Individually pack the instruments or, in case several instruments are placed inside the same bag, make sure they are made of the same metal;
- Seal the case with a thermosealer or adhesive tape for autoclaves;
- Do not use metal staples, needles or the like, as sterility could be affected;
- Lay the bags so as to avoid the creation of air pockets, which could potentially prevent steam correct penetration and removal;
- Position bags in such a way to leave the paper side up and the plastic side down (tray side);
- In any case, check the effectiveness of this position with regard to the effectiveness of drying, reversing it if necessary;
- If possible, using a suitable support, position bags at right angles with tray;
- Never stack bags one on top of the other.





**Always pack instruments if they have to be stored for a long time.
Refer also to the indications given in chapter “sterilized material storage”.**

Program selection is an essential operation for the correct performance of the sterilization process.

Since all instruments, or material in general, have a different structure, consistency and properties, the **most suitable program must be identified**, both to preserve the physical characteristics (avoiding or, in any case, limiting its alterations) and to ensure the best effectiveness of the sterilization process. A guide for the selection of the correct program based on the load is present inside **Programs Appendix**.

7.3. POSITIONING AND USING THE TRAY HOLDER SUPPORT

Tray holder support can be used in "tray" version (5/6 compartments based on the sterilizer model).



Or, if tray holder support is extracted and turned by 90°, it can be used to house special "boxes" (3/4 compartments based on sterilizer model).



In any case, it is possible to position the boxes (3 or 4 depending on the sterilizer model) vertically.

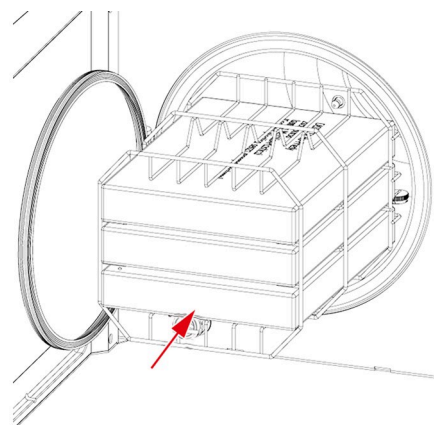
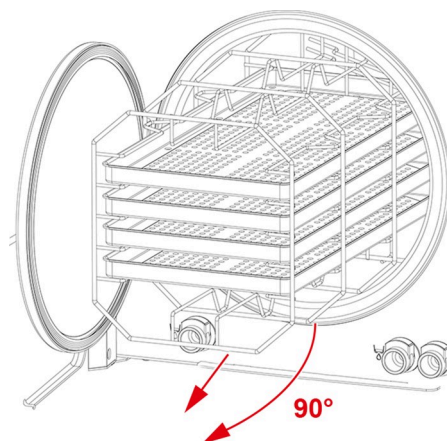

8. STERILIZATION CYCLES

A sterilization cycle consists of a determined number of phases.

The number and duration of the phases can differ for the different cycles, based on the type of air extraction, sterilization process and drying methods.

Available cycles are:

- **B 134 °C Universal**
- **B 121 °C Universal**
- **B 134 °C Prion**
- **S 134 °C Solid Wrapped**
- **S 134 °C Fast**
- **Custom** (user-defined)

The electronic control system monitors the various phases, at the same time checking that the various parameters are respected; if any type of anomaly is encountered during the cycle, the program is immediately interrupted, generating an alarm identified by a code, with a relative message explaining the nature of the problem. With this type of control, when you select a suitable sterilization program, you are guaranteed an effective sterilization under any external conditions.

After inserting the load in the sterilization chamber (taking the precautions described in the section "Preparing the material to be sterilized"), select the desired sterilization cycle.

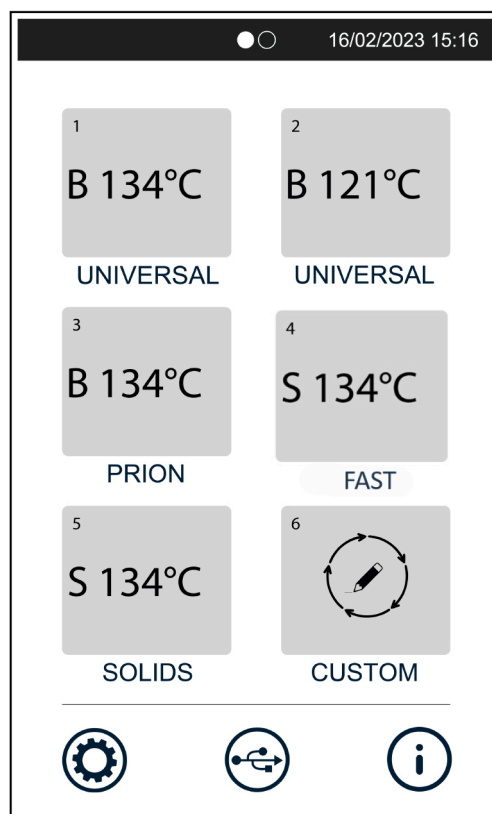

Start the cycle by pressing the indicated START button.
The cycle counter appears in the top centre.

In the middle, below the START button, the following data appears:

- Total cycle time (estimated);
- Process time;
- Process rated pressure;
- Process rated temperature;

The following information are shown at the bottom of the screen:

- Delayed start
- Extra drying (if enabled)

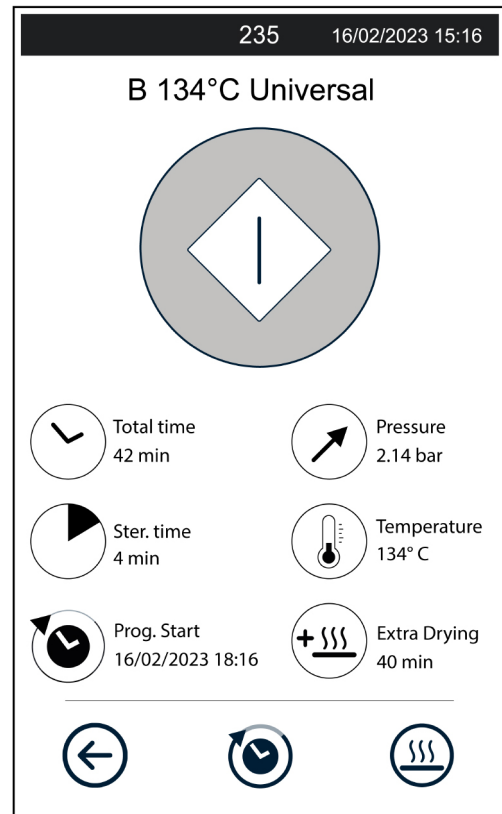

8.1. DRYING MANAGEMENT

Select the DRYING MANAGEMENT option by pressing the indicated button.

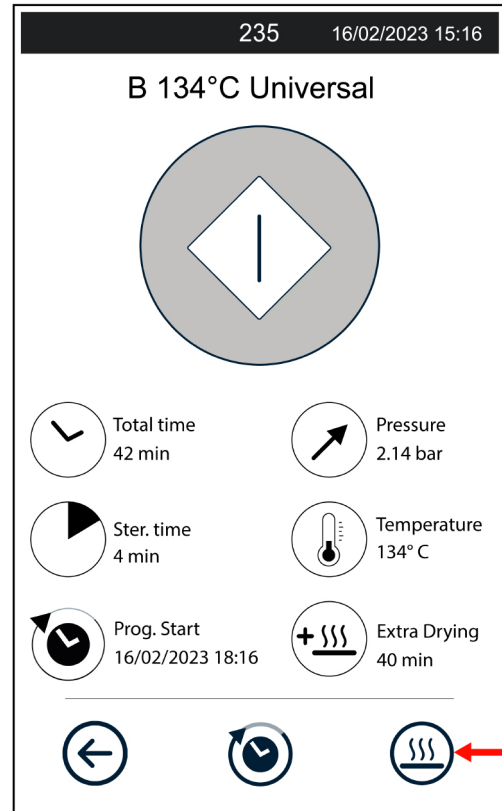

EXTRA DRYING

Using the appropriate icon, select the activation of the function to increase the expected drying time for each cycle.

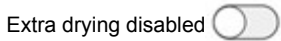

By scrolling, select the additional drying time (minutes).

Confirm the entry with the icon (A).

Pressing the button corresponding to the EXIT icon returns to the previous menu without saving the changes made.

After the confirmation, the extra drying value appears at the bottom of the previous screen.

The additional value remains saved.

MODULAR DRYING

This function allows the drying time to be adapted to the load, significantly reducing the total cycle time.

You can select:

- **MAX** - sets the standard drying times provided for the maximum loads differentiated by type of material
- **MIN** - sets reduced drying times provided for minimum loads differentiated by type of material, using only 2 trays.

Refer to the SUMMARY TABLE OF CYCLES for maximum and minimum loads required for the different cycles and materials.

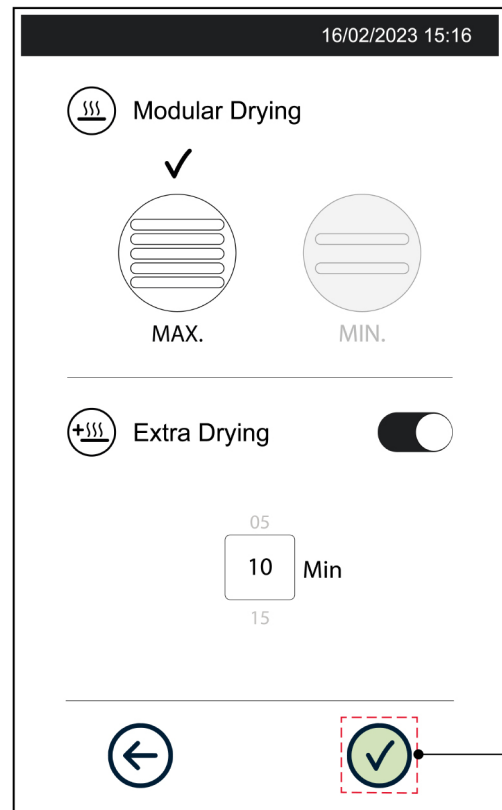

At next use, just press the extra drying button to activate the values previously set.



EXTRA DRYING and MODULAR DRYING can be set independently for each cycle.



EXTRA DRYING can only be activated with MODULAR DRYING set to MAX.



The efficiency with MODULAR DRYING MIN is ensured only by respecting the maximum load values indicated in the SUMMARY TABLE OF CYCLES.

8.2. DELAY START

Select the DELAY START option by pressing the indicated button.

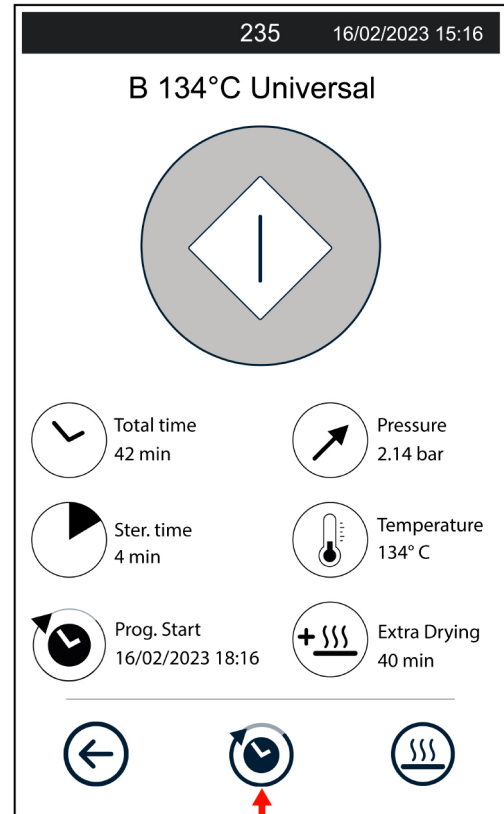

Use the relevant icon to select whether the delayed start is to be enabled or not.

Delayed start active 

Delayed start disabled 

By scrolling, select the start delay (minutes).

Confirm the entry with the ✓ icon.

Pressing the button corresponding to the EXIT icon returns to the previous menu without saving the changes made.

After confirmation, the start date and time, which are set for the cycle start, will appear at the bottom of the previous screen.

The additional value remains saved.

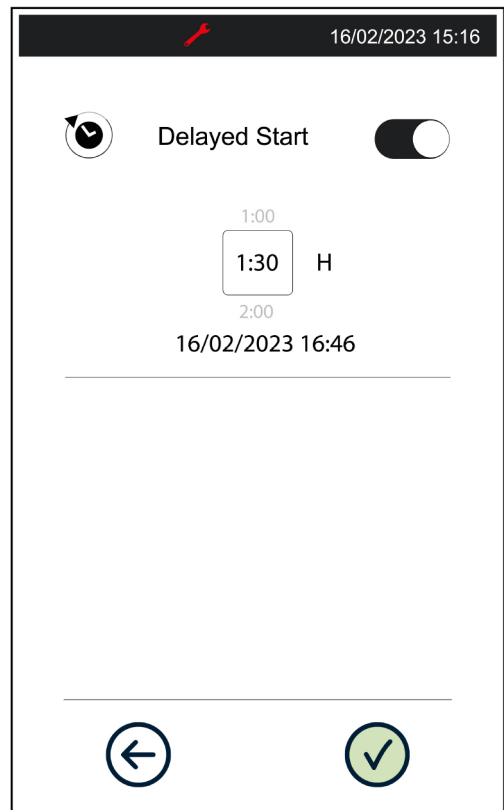

 At next use, just press the delay start button to activate the values previously set.

8.3. EXECUTION OF THE CYCLE

Taking as example the most complete and significant sterilization cycle, i.e. the **B 134 °C Universal** program, characterised by fractionated pre-vacuum, the cycle sequence is as follows:

- WARMING UP
- FIRST VACUUM PHASE
- FIRST PRESSURE RISE
- SECOND VACUUM PHASE
- SECOND PRESSURE RISE
- THIRD VACUUM PHASE
- THIRD PRESSURE RISE
- STERILIZATION
- STEAM DISCHARGE
- DRYING
- VENTILATION
- CYCLE COMPLETION

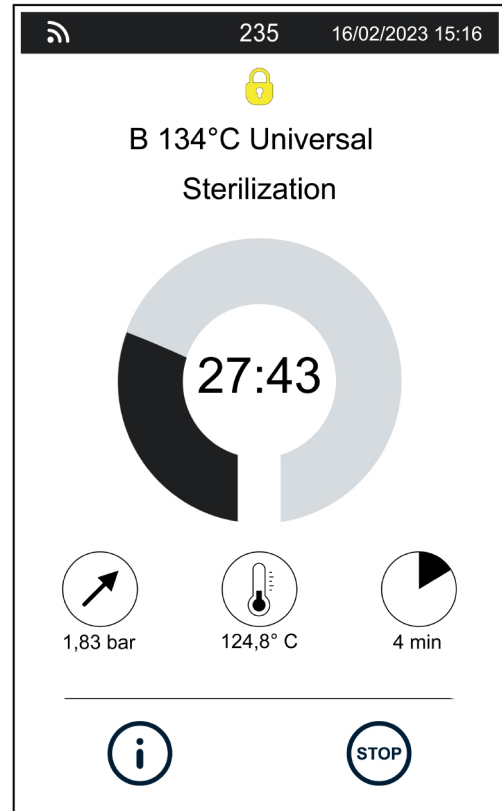

8.4. CYCLE OUTCOME

At the end of the cycle it is essential to check the sterilization process outcome.

If the message "CYCLE COMPLETED" is displayed, it means that the cycle has been completed correctly without any interruptions for alarms and that **asepsis** conditions of the material are guaranteed.

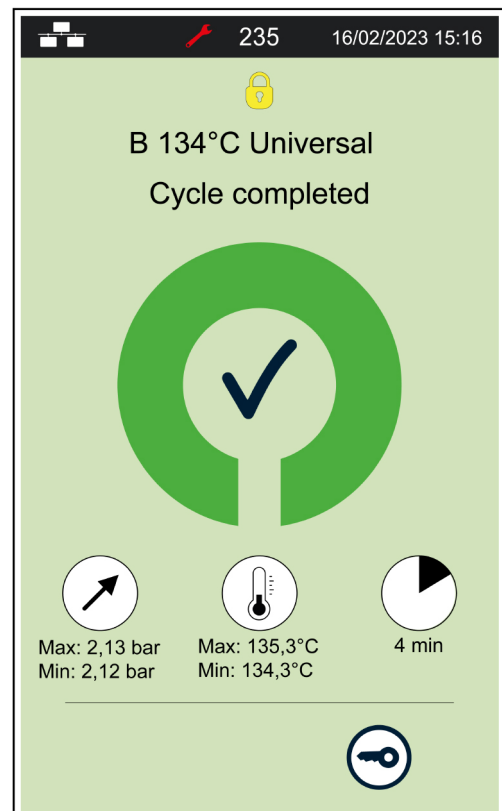

8.5. DOOR OPENING AT CYCLE END

To open the sterilizer door, press the button shown in the figure.

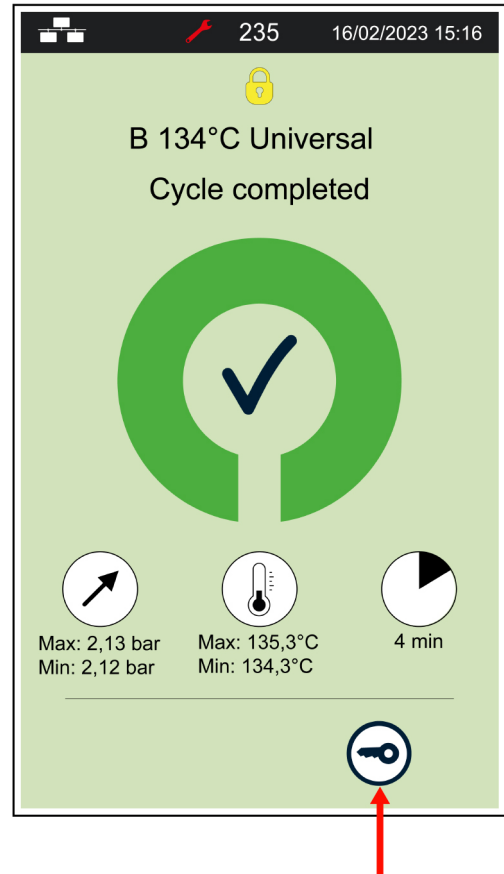

The door unlocks and stays ajar.

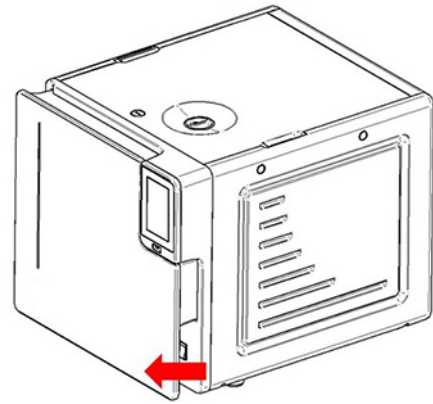

Now you can manually open the door.

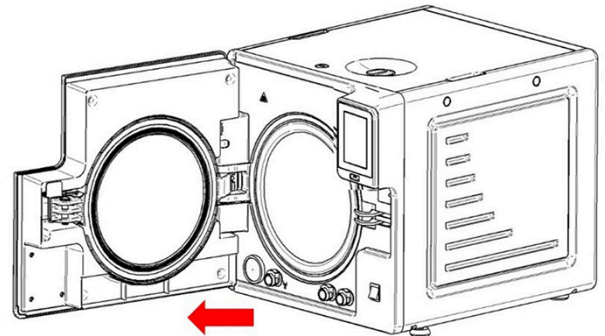

8.6. USER-DEFINED CYCLE

Select the Custom cycle option.

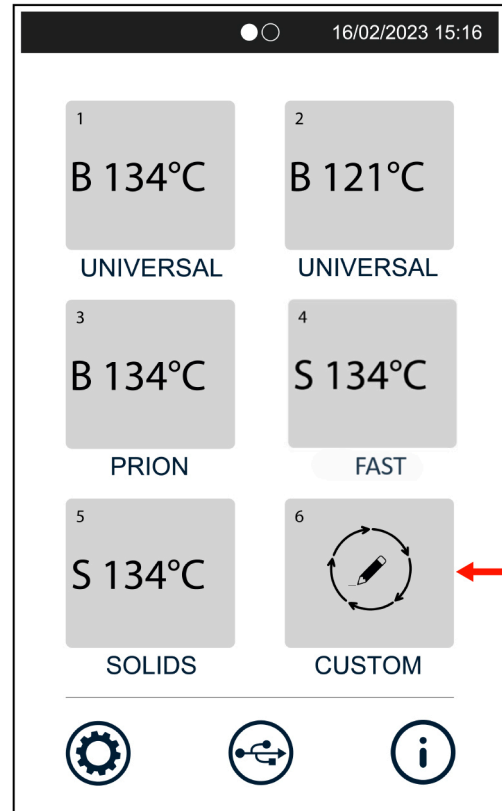

In the middle, below the START button, the following data appears:

- Total cycle time (estimated);
- Process time;
- Process rated pressure;
- Process rated temperature;

The following information are shown at the bottom of the screen:

- Delayed start (if active)

To start the cycle press the START button.

Select the appropriate button to enter the cycle parameters change screen.

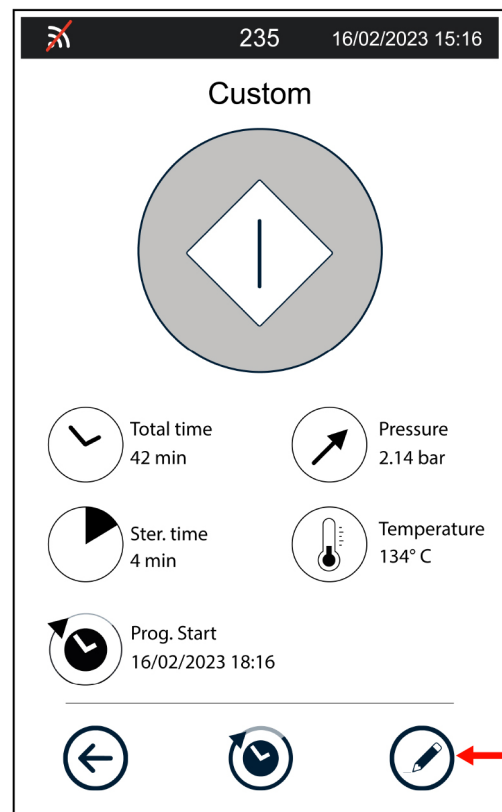

The icons show the 4 settable values:

- Vacuum phases: 1 - single vacuum / 3 - fractionated vacuum;
- Sterilization temperature: 121°C/134°C;
- Drying time: standard drying time that can be increased up to a maximum of 30'
- Sterilization time: minimum time expected for the temperature set, it can be increased up to a maximum of 30' (in 1' steps);

To change the editable parameters of the Custom cycle:

Select among the preset parameters for the Vacuum phases and Sterilization temperature items.

By scrolling, select the desired value for Drying time and Sterilization time items.

Confirm the entry with the ✓ icon.

Pressing the button corresponding to the EXIT icon returns to the previous menu without saving the changes made.

At first start-up, the default parameters are those of the B 134 °C Universal cycle.

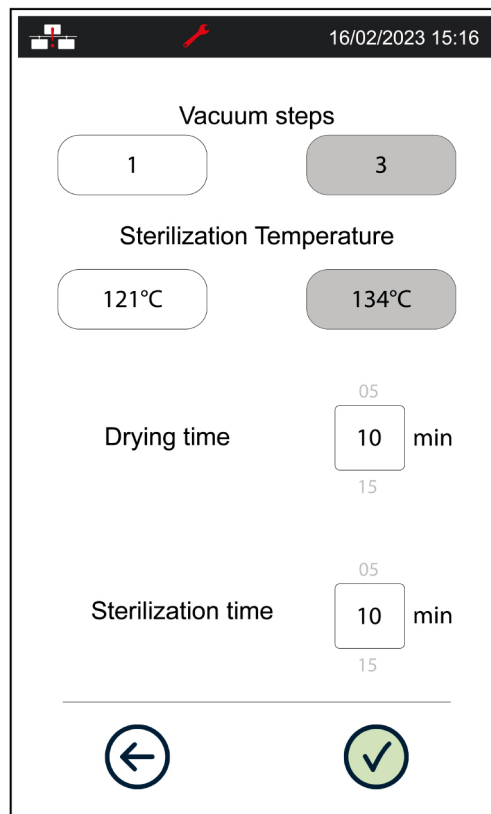

9. MATERIAL STORAGE

The sterilized material must be adequately treated and stored to maintain its sterility over time, until its use.

Inadequate storage **can** cause **rapid recontamination**.

This leads to problems regardless of what you do since you will either be using recontaminated material (most of the time unconsciously), placing the user and patient at risk, or you will have to run the sterilization cycle again, with an inevitable waste of time and resources.

For this reason, we think it will be useful to provide several basic suggestions, leaving the operator the task of further study of specific texts.

Assuming that the sterilizer is located in a clean place, free of dust and not too damp, the following precautions should be taken when handling and/or carrying sterile material:

1. Remove the load from the sterilization chamber wearing gloves and a clean, or even better, sterilized smock. As an additional precaution, wear a protective mask on your face;
2. Rest the trays on a dry, suitably clean and disinfected surface. Take care to distance or, at any rate, separate the sterile material from the area where contaminated material is kept waiting to be sterilized;
3. Touch the material and/or instruments as little as possible, taking extreme care not to cut or damage the wrappings.

Let the instruments cool before any transport (and subsequent storage). If necessary for transport, transfer the material using dry, clean and disinfected containers.

The containers must be closed or, if open, covered with clean cloths.

Before use, sterile material must be stored using the appropriate techniques.

These will significantly **slow** recontamination:

1. Store the material and/or instruments in the protective wrappings that were used during sterilization. Do not bag instruments after sterilization.
2. Store the material in a dry, suitably clean and disinfected place, far from the area where infected material passes. If possible, use closed compartments equipped with ultraviolet light;
3. Identify the sterile material by attaching the sterilization date (enclosing a copy of the printed report or an adhesive label);
4. First use the material that has been stored the longest (FIFO, "First In First Out"). This results in material that is homogeneously stored, avoiding storing it for too long, with the consequent risks.
5. Never store material for too long. In fact, do not overlook the fact that materials will tend to degrade and be recontaminated in a finite time, even when the above instructions are followed.



Consult the specifications provided by the manufacturer of the packaging material relative to the maximum allowed storage time.



Such storage times may vary from country to country, according to the local legal requirements.

10. TEST PROGRAMS

To protect the safety of users and patients, a fundamental process like sterilizing medical devices should be periodically checked.

The device offers the possibility of easily and automatically executing two distinct test cycles:

- **Helix/B&D Test;**
- **Vacuum Test** (OR VACUUM TEST);
- There is also a program that runs, in sequence, **Vacuum + H/B&D;**
There is also a further test to check the water quality: **H2O Test.**

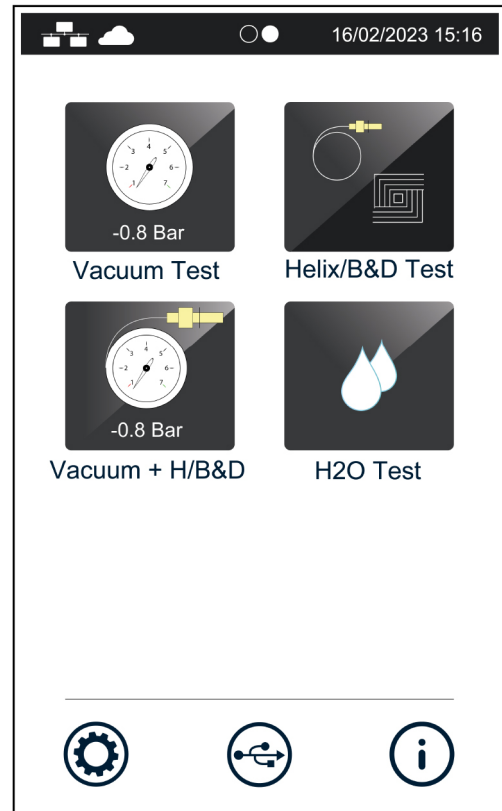

10.1. HELIX/B&D TEST CYCLE

Helix/B&D Test is a cycle run at 134°C characterised by a sterilization phase that lasts a specific time (3.5 minutes); the cycle comprises the fractionated vacuum phases similar to those used in the sterilization cycles.

Using an appropriate device, you can assess correct steam penetration into hollow loads (**Helix Test**).

The cycle is also suitable to measure steam penetration into porous loads (**Bowie & Dick test pack**).

To select the **Helix/B&D Test** cycle, scroll the menu, press the corresponding button and then press START.

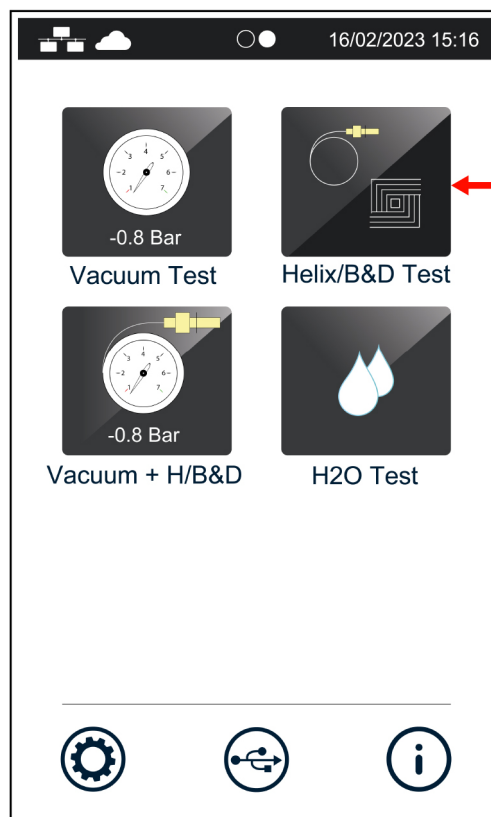

The Helix test device (in accordance with EN 867-5 specifications) consists of a 1.5 m-long PTFE tube, with an inside diameter of 2 mm to whose end a small hermetically-sealed screw cap is fastened, able to contain an appropriate chemical indicator.

The other end of the tube is left free so that the steam can penetrate and you can assess its effectiveness.

To conduct the test (with reference to standard EN 13060), insert the chemical indicator, consisting of a paper strip with a special reagent ink in the device cap (always to be used perfectly dry). Tighten the cap in such a way that seepage through the gasket is not possible.



The device and the chemical indicators to execute the Helix/B&D Test cycle are not provided with the device. For information in this regard, contact technical service department (see appendix).

Place the device roughly in the middle of the central tray. Do not insert other material in the chamber. Close the door and start the cycle.

The test cycle takes place with a succession of phases similar to those described for a normal sterilization cycle.

At the end of the cycle, remove the test device from the chamber, open the cap and remove the indicator from its housing.

If the steam has correctly penetrated, the ink will have completely changed its original colour over the entire length of the strip; if not (insufficient penetration), there will only be a partial colour change or even no change at all.

The same cycle can be used for the Bowie & Dick test at the same time by placing the test device next to the Helix test device.

The Bowie & Dick test package includes a chemical indicator inserted between various layers of porous material, consisting of a sheet with a special reagent ink on its surface. If the steam penetration through the porous material layers is correct, it will make the ink colour change evenly throughout the entire surface of the B&D indicator. If this is not the case, the toning will not occur or will be partial.



Toning usually occurs from a light colour (beige, yellow, etc.) to a dark colour (blue, violet or black). In any event, strictly follow the instructions and any additional technical details provided by the indicator manufacturer.

10.2. VACUUM TEST CYCLE

The Vacuum Test cycle allows testing perfect seal of the sterilizer hydraulic system.

Measuring the variation of the degree of vacuum in a defined time-frame and comparing it with pre-established limit values, you can determine how good the seal of the sterilization chamber, tubes and the various interception devices is.

To select the **Vacuum Test** cycle, scroll the menu, press the corresponding button and press START.

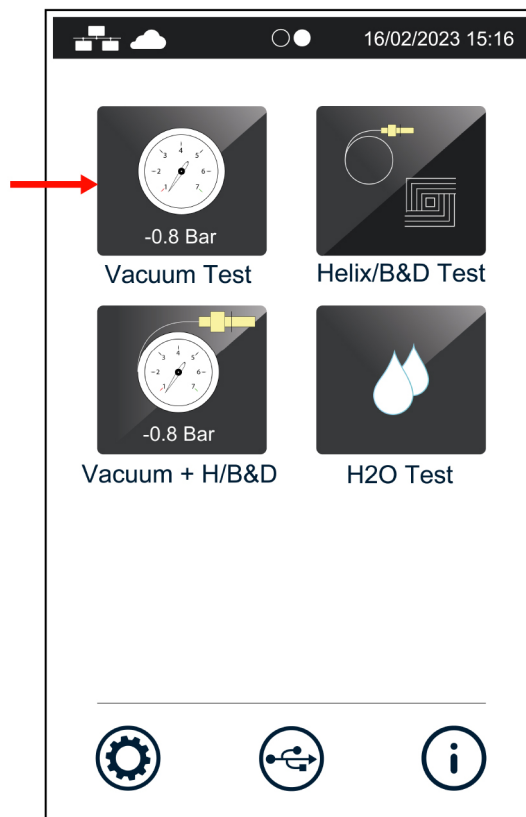

The cycle should be performed without load, with only the tray holder support and trays inserted in the chamber.

 *We suggest to run this test at the beginning of each working day with chamber at ambient temperature.*

A high chamber temperature affects the variation in the vacuum value measured during the test; the system is therefore programmed to prevent execution of the test when the operating conditions are inadequate.

Close the door and start the program.

The vacuum phase starts immediately and the pressure value (bar) and the countdown from the start of the test cycle are shown on the display.

 *If the pressure variation exceeds the limit defined, the program is interrupted and an alarm message generated.
For the complete description of the alarms refer to appendix.*

10.3. VACUUM + H/B&D CYCLE

Select this option to run a **Vacuum Test** cycle and a **Helix/B&D Test** cycle in sequence.

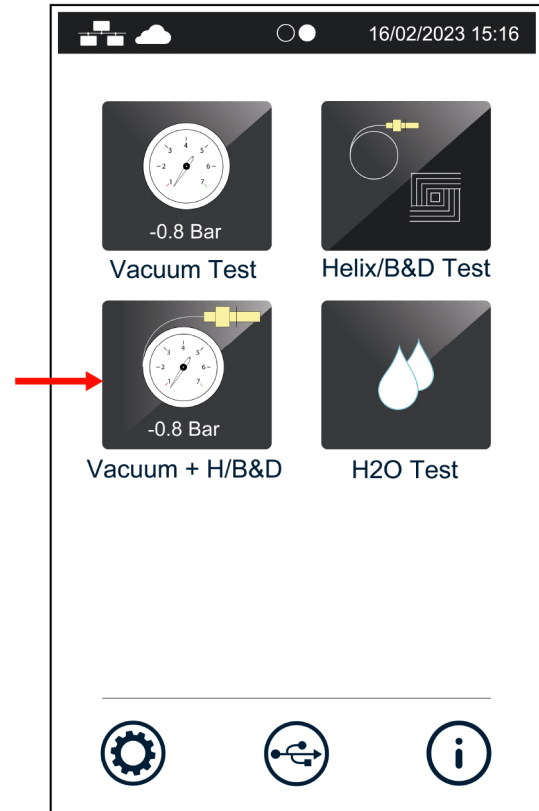

To this end, place the Helix test device and/or the Bowie & Dick test package on the central tray without inserting other material. Close the door and start the cycle.

The program will run the two cycles in succession: after successful completion of the Vacuum Test, the Helix/B&D test will automatically run. Check the results as described in the previous paragraphs.

 *The presence of the Helix Test device and/or of the Bowie & Dick test device does not alter the execution and the result of the Vacuum Test cycle.*

10.4. H2O TEST

Select this option to test the quality of the water contained in the load tank.

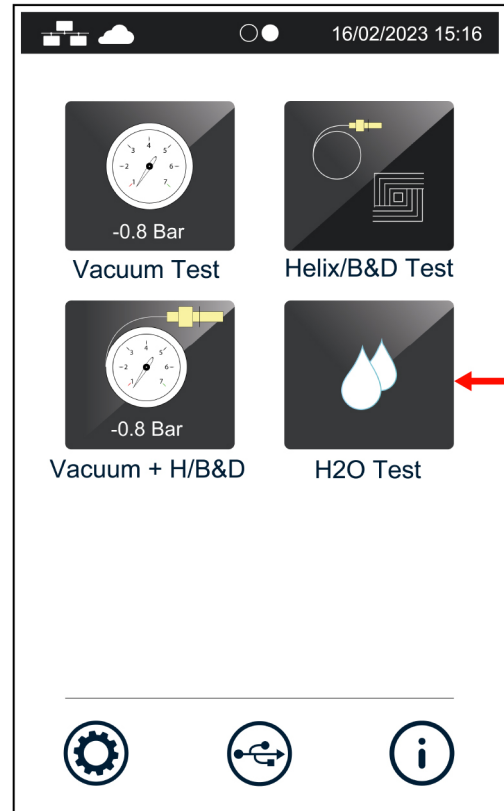

Pressing the button corresponding to the EXIT icon returns to the previous menu.

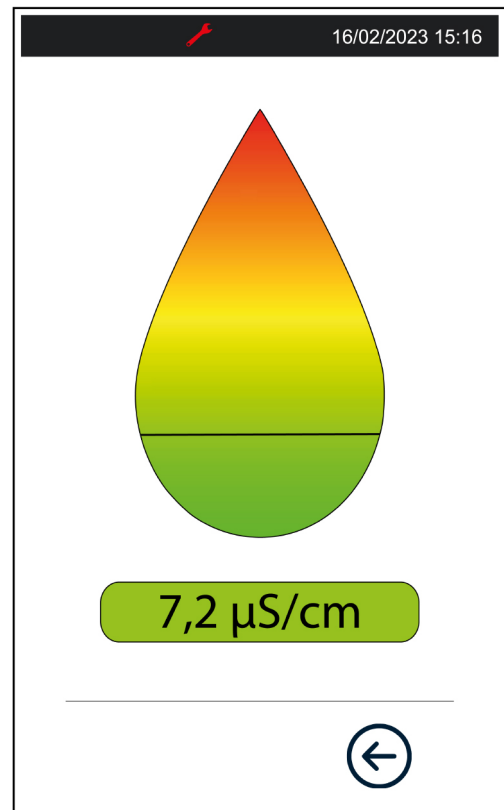

 The water conductivity is automatically measured at each sterilization or test cycle start and the relative value is indicated in the cycle report.

10.5. MANUAL INTERRUPTION

The cycle can be manually interrupted by the operator at any moment, by pressing the **STOP** button.

A pop-up asking for confirmation of cycle interruption will be displayed.

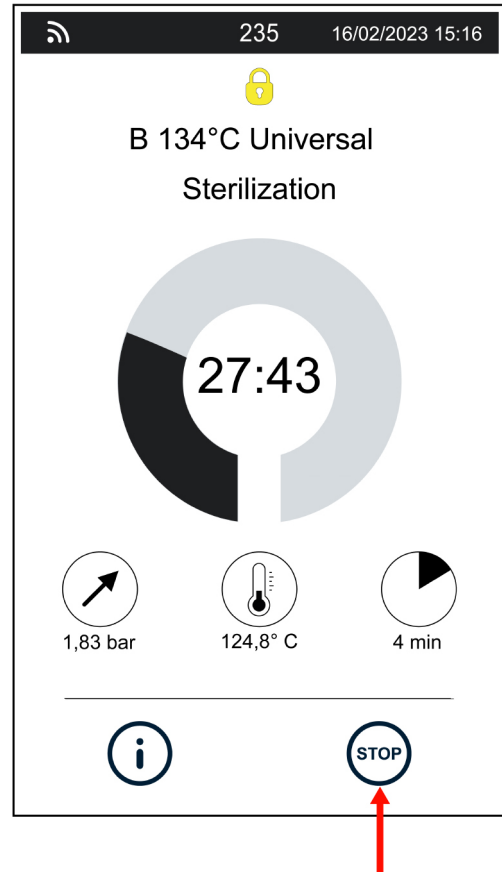

The command generates **ERROR E999** as the cycle was not correctly completed. Press ENTER to proceed.



If the cycle is interrupted during certain cycle phases, an automatic cleaning procedure of the internal hydraulic circuit starts. For the complete description of the alarms refer to "ALARM INDICATION" appendix.

Press and hold **RESET** for about three seconds to open the door.

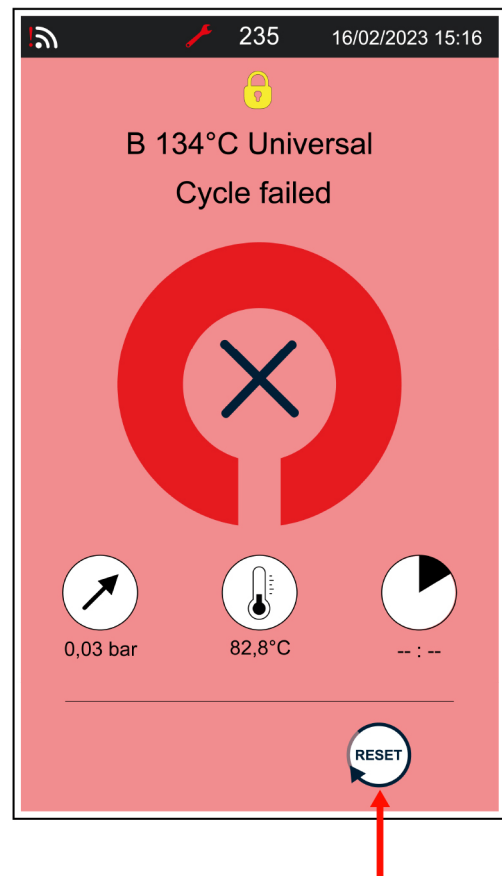

After a manual interruption of the program, the load must not be used since the sterilization is not ensured.

11. DRAINING THE USED WATER

When the water maximum level is reached, a specific message is displayed.

Open the door and continue as follows:

1. Prepare a bowl with a capacity of at least 4 litres in proximity to the sterilizer; place the free end of the drain tube provided in the bowl;
2. Insert the other end of the tube in the female union beneath the chamber inlet (connector on the left) pushing down until you hear a click;
3. Completely empty out the tank and then press on the upper part of the union and detach the tube quick coupling.



Do not open the tank doors during the cycle execution in order to prevent hot water leaks or spurts.

Detaching the tube

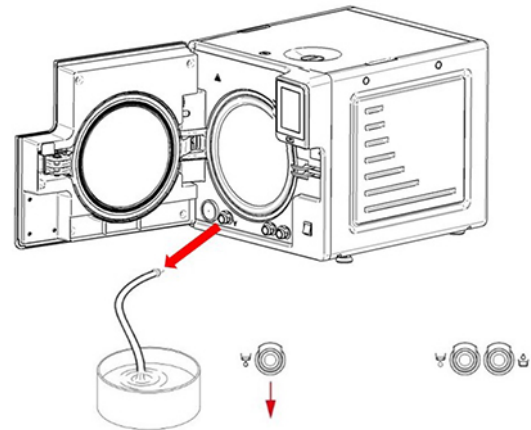
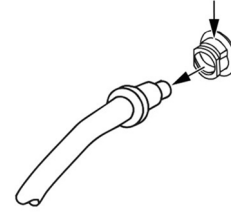

12. APPENDIX - PROGRAMS

Water steam sterilization is suitable for almost all the materials and instruments, provided that they can bear without damage a **minimum temperature of 121°C** (if this is not the case, other low-temperature sterilization systems must be used).

The following material can normally be sterilized with water steam:

- Stainless steel surgical/generic instruments;
- Carbon steel surgical/generic instruments;
- Rotating and/or vibrating instruments driven by compressed air (turbines) or mechanical transmission (contra angles, tooth scalers);
- Glass items;
- Mineral-based items;
- Heat-resistant plastic items;
- Heat-resistant rubber items;
- Heat-resistant textiles;
- Medication materials (gauze, pads, etc.);
- Other generic material suitable for autoclave treatment.

 Depending on the material conformation (solid, hollow or porous), on any package containing it (paper/plastic bag, paper for sterilization, container, muslin napkins, etc.) and on its resistance to heat, it is essential to choose the suitable sterilization program, referring to the table in the next page.



The device must not be used for the sterilization of fluids, liquids or pharmaceutical products.



"Prion" cycle:

The reference standard for this device, EN13060, does not lay down any requirements for inactivation processes of agents causing spongiform encephalopathies as scrapie, bovine spongiform encephalopathy and Creutzfeldt-Jakob disease.

The cycle named "Prion" (18 min at 134 °C) applies national regulations, which indicate this modified steam sterilization process as part of a prion decontamination program.

12.1. SUMMARY TABLE OF 17 220 V - 240 V CYCLES

CYCLE DESCRIPTION	NOMINAL VALUES			BASIC CYCLE PARAMETERS					
	Temp. (°C) - Press. (bar)	Maint. time (min)	Cycle type (EN 13060:2014 + A1:2018)	Pre-vacuum (F=fractionated; S=single)	Standard drying (max)	Modular drying (min)	Total cycle time (medium load)**	Max H2O consumption (ml/cycle)	Average energy consumption (kWh/cycle)
B 134 °C Universal	134 2.1	4(*)	B	F	13	7	39	550	0.75
B 134 °C Prion	134 2.1	18	B	F	13	7	53	600	0.85
B 121 °C Universal	121 1.1	20	B	F	13	-	53	600	0.75
S 134 °C Fast	134 2.1	4(*)	S	F	1	-	21	450	0.65
S 134 °C Solid Wrapped	134 2.1	4(*)	S	S	13	7	32	350	0.55
Custom	134 2.1 ----- 121 1.1	4+30 ----- 20+30	n.a.	F/S	5+30	n.a.	n.a.	n.a.	n.a.
Helix/B&D Test	134 2.1	3.5	-	F	1	-	20	-	-
Vacuum Test	-	-	-	-	-	-	18	-	-
Vacuum + Helix/B&D Test (can be performed in sequence)	-	-	-	-	-	-	42	-	-

CYCLE DESCRIPTION	STERILIZABLE MATERIALS					NOTES
	TYPE	MAX TOTAL MASS (kg)	MAX MASS PER TRAY (kg)	MAX MASS PER ITEM (kg)	MAX MODULAR DRYING TOTAL MASS (kg)	
B 134 °C Universal	Unwrapped porous materials	1.00	0.30	0.30	0.40	For wrapped materials and instruments (single and double pack), it is advisable to use the 3-tray configuration
	Porous materials in single pack	0.75	0.25	0.25	0.30	
	Porous materials in double pack	0.60	0.20	0.20	0.20	
	Solid and hollow materials in single pack	3.00	1.00	0.50	1.00	
	Unwrapped solid and hollow materials	6.00	1.20	0.25	2.00	
	Solid and hollow instruments in double pack	1.50	0.50	0.25	0.50	
B 134 °C Prion	Unwrapped porous materials	1.00	0.30	0.30	0.40	
	Porous materials in single pack	0.75	0.25	0.25	0.30	
	Porous materials in double pack	0.60	0.20	0.20	0.20	
	Solid and hollow materials in single pack	3.00	1.00	0.50	1.00	
	Unwrapped solid and hollow materials	6.00	1.20	0.25	2.00	
	Solid and hollow instruments in double pack	1.50	0.50	0.25	0.50	

CYCLE DESCRIPTION	STERILIZABLE MATERIALS					NOTES
	TYPE	MAX TOTAL MASS (kg)	MAX MASS PER TRAY (kg)	MAX MASS PER ITEM (kg)	MAX MODULAR DRYING TOTAL MASS (kg)	
B 121 °C Universal	Unwrapped porous materials	1.00	0.30	0.30	0.40	
	Porous materials in single pack	0.75	0.25	0.25	0.30	
	Porous materials in double pack	0.60	0.20	0.20	0.20	
	Solid and hollow materials in single pack	3.00	1.00	0.50	1.00	
	Unwrapped solid and hollow materials	6.00	1.20	0.25	2.00	
	Solid and hollow instruments in double pack	1.50	0.50	0.25	0.50	
S 134 °C Fast	Unwrapped hollow instruments	2.00	1.20	0.50	-	
	Unwrapped solid instruments	2.00	1.20	0.50	-	
S 134 °C Solid Wrapped	Solid and hollow instruments "B" in single pack	3.00	1.00	0.25	1.00	It is advisable to use the 3-tray configuration
	Unwrapped solid and hollow materials "B"	6.00	1.20	0.50	2.00	
Custom	Unwrapped solid instruments (other load types are possible depending on the user settings)	n.a.	n.a.	n.a.	n.a.	Variable parameters depending on the settings made
Helix/B&D Test	Test device only (without another load)	-	-	-		No other load
Vacuum Test	Trays and support only	-	-	-		
Vacuum + Helix/B&D Test (can be performed in sequence)	Trays, support and test devices only	-	-	-		

-  (*) To set a sterilization time of 5.5 minutes, contact the Technical Service.
- (**) With the activation of modular drying (min), the total cycle time is reduced by between 10 and 15 minutes, depending on the cycle and chamber size considered.
- Single Pre-Vacuum = 1 pre-vacuum; -0.8 bar (see figures in the following pages).
- Fractionated Pre-Vacuum = 3 pre-vacuum; -0.8 bar each (see figures in the following pages).
- Definition of hollow loads in accordance with standard EN 13060:2014 + A1:2018.
- The term "hollow loads" in this manual refers both to "narrow lumen" elements (section 3.18 EN 13060:2014 + A1:2018) and "simple hollow" elements (section 3.30 EN 13060:2014 + A1:2018).
- The term "hollow load B" refers ONLY to "simple hollow" elements (section 3.30 EN 13060:2014 + A1:2018).

12.2. SUMMARY TABLE OF 17 120 V CYCLES

CYCLE DESCRIPTION	NOMINAL VALUES			BASIC CYCLE PARAMETERS					
	Temp. (°C) - Press. (bar)	Maint. time (min)	Cycle type (EN 13060:2014 + A1:2018)	Pre-vacuum (F=fractionated; S=single)	Standard drying (max)	Modular drying (min)	Total cycle time (medium load)**	Max H2O consumption (ml/cycle)	Average energy consumption (kWh/cycle)
B 134 °C Universal	134 2.1	4(*)	B	F	13	7	39	550	0.75
B 134 °C Prion	134 2.1	18	B	F	13	7	53	600	0.85
B 121 °C Universal	121 1.1	20	B	F	13	-	53	600	0.75
S 134 °C Fast	134 2.1	4(*)	S	F	1	-	21	450	0.65
S 134 °C Solid Wrapped	134 2.1	4(*)	S	S	13	7	32	350	0.55
Custom	134 2.1 ----- 121 1.1	4+30 ----- 20+30	n.a.	F/S	5+30	n.a.	n.a.	n.a.	n.a.
Helix/B&D Test	134 2.1	3.5	-	F	1	-	20	-	-
Vacuum Test	-	-	-	-	-	-	18	-	-
Vacuum + Helix/B&D Test (can be performed in sequence)	-	-	-	-	-	-	42	-	-

CYCLE DESCRIPTION	STERILIZABLE MATERIALS					NOTES
	TYPE	MAX TOTAL MASS (kg)	MAX MASS PER TRAY (kg)	MAX MASS PER ITEM (kg)	MAX MODULAR DRYING TOTAL MASS (kg)	
B 134 °C Universal	Unwrapped porous materials	1.00	0.30	0.30	0.40	For wrapped materials and instruments (single and double pack), it is advisable to use the 3-tray configuration
	Porous materials in single pack	0.75	0.25	0.25	0.30	
	Porous materials in double pack	0.60	0.20	0.20	0.20	
	Solid and hollow materials in single pack	3.00	1.00	0.50	1.00	
	Unwrapped solid and hollow materials	6.00	1.20	0.25	2.00	
	Solid and hollow instruments in double pack	1.50	0.50	0.25	0.50	
B 134 °C Prion	Unwrapped porous materials	1.00	0.30	0.30	0.40	
	Porous materials in single pack	0.75	0.25	0.25	0.30	
	Porous materials in double pack	0.60	0.20	0.20	0.20	
	Solid and hollow materials in single pack	3.00	1.00	0.50	1.00	
	Unwrapped solid and hollow materials	6.00	1.20	0.25	2.00	
	Solid and hollow instruments in double pack	1.50	0.50	0.25	0.50	

CYCLE DESCRIPTION	STERILIZABLE MATERIALS					NOTES
	TYPE	MAX TOTAL MASS (kg)	MAX MASS PER TRAY (kg)	MAX MASS PER ITEM (kg)	MAX MODULAR DRYING TOTAL MASS (kg)	
B 121 °C Universal	Unwrapped porous materials	1.00	0.30	0.30	0.40	
	Porous materials in single pack	0.75	0.25	0.25	0.30	
	Porous materials in double pack	0.60	0.20	0.20	0.20	
	Solid and hollow materials in single pack	3.00	1.00	0.50	1.00	
	Unwrapped solid and hollow materials	6.00	1.20	0.25	2.00	
	Solid and hollow instruments in double pack	1.50	0.50	0.25	0.50	
S 134 °C Fast	Unwrapped hollow instruments	2.00	1.20	0.50	-	
	Unwrapped solid instruments	2.00	1.20	0.50	-	
S 134 °C Solid Wrapped	Solid and hollow instruments "B" in single pack	3.00	1.00	0.25	1.00	It is advisable to use the 3-tray configuration
	Unwrapped solid and hollow materials "B"	6.00	1.20	0.50	2.00	
Custom	Unwrapped solid instruments (other load types are possible depending on the user settings)	n.a.	n.a.	n.a.	n.a.	Variable parameters depending on the settings made
Helix/B&D Test	Test device only (without another load)	-	-	-	-	No other load
Vacuum Test	Trays and support only	-	-	-	-	
Vacuum + Helix/B&D Test (can be performed in sequence)	Trays, support and test devices only	-	-	-	-	

-  (*) To set a sterilization time of 5.5 minutes, contact the Technical Service.
- (**) With the activation of modular drying (min), the total cycle time is reduced by between 10 and 15 minutes, depending on the cycle and chamber size considered.
- Single Pre-Vacuum = 1 pre-vacuum; -0.8 bar (see figures in the following pages).
- Fractionated Pre-Vacuum = 3 pre-vacuum; -0.8 bar each (see figures in the following pages).
- Definition of hollow loads in accordance with standard EN 13060:2014 + A1:2018.
- The term "hollow loads" in this manual refers both to "narrow lumen" elements (section 3.18 EN 13060:2014 + A1:2018) and "simple hollow" elements (section 3.30 EN 13060:2014 + A1:2018).
- The term "hollow load B" refers ONLY to "simple hollow" elements (section 3.30 EN 13060:2014 + A1:2018).

12.3. SUMMARY TABLE OF 22 220 V - 240 V CYCLES

CYCLE DESCRIPTION	NOMINAL VALUES			BASIC CYCLE PARAMETERS					
	Temp. (°C) - Press. (bar)	Maint. time (min)	Cycle type (EN 13060:2014 + A1:2018)	Pre-vacuum (F=fractionated; S=single)	Standard drying (max)	Modular drying (min)	Total cycle time (medium load)**	Max H2O consumption (ml/cycle)	Average energy consumption (kWh/cycle)
B 134 °C Universal	134 2.1	4(*)	B	F	15	9	42	700	0.80
B 134 °C Prion	134 2.1	18	B	F	15	9	56	750	0.90
B 121 °C Universal	121 1.1	20	B	F	15	9	59	750	0.80
S 134 °C Fast	134 2.1	4(*)	S	F	1	-	24	500	0.65
S 134 °C Solid Wrapped	134 2.1	4(*)	S	S	15	9	37	400	0.60
Custom	134 2.1 ----- 121 1.1	4÷30 - 20÷30	n.a.	F/S	5÷30	n.a.	n.a.	n.a.	n.a.
Helix/B&D Test	134 2.1	3.5	-	F	1	-	24	-	-
Vacuum Test	-	-	-	-	-	-	18	-	-
Vacuum + Helix/B&D Test (can be performed in sequence)	-	-	-	-	-	-	46	-	-

CYCLE DESCRIPTION	STERILIZABLE MATERIALS					NOTES
	TYPE	MAX TOTAL MASS (kg)	MAX MASS PER TRAY (kg)	MAX MASS PER ITEM (kg)	MAX MODULAR DRYING TOTAL MASS (kg)	
B 134 °C Universal	Unwrapped porous materials	1.20	0.40	0.30	0.50	For wrapped materials and instruments (single and double pack), it is advisable to use the 3-tray configuration
	Porous materials in single pack	1.00	0.30	0.25	0.40	
	Porous materials in double pack	0.75	0.25	0.20	0.30	
	Solid and hollow materials in single pack	4.00	1.25	0.25	1.50	
	Unwrapped solid and hollow materials	7.50	1.20	0.25	2.50	
	Solid and hollow instruments in double pack	2.00	0.60	0.25	1.00	
B 134 °C Prion	Unwrapped porous materials	1.20	0.40	0.30	0.50	
	Porous materials in single pack	1.00	0.30	0.25	0.40	
	Porous materials in double pack	0.75	0.25	0.20	0.30	
	Solid and hollow materials in single pack	4.00	1.25	0.25	1.50	
	Unwrapped solid and hollow materials	7.50	1.20	0.25	2.50	
	Solid and hollow instruments in double pack	2.00	0.60	0.25	1.00	
B 121 °C Universal	Unwrapped porous materials	1.20	0.40	0.30	0.50	

CYCLE DESCRIPTION	STERILIZABLE MATERIALS					NOTES
	TYPE	MAX TOTAL MASS (kg)	MAX MASS PER TRAY (kg)	MAX MASS PER ITEM (kg)	MAX MODULAR DRYING TOTAL MASS (kg)	
	Porous materials in single pack	1.00	0.30	0.25	0.40	
	Porous materials in double pack	0.75	0.25	0.20	0.30	
	Solid and hollow materials in single pack	4.00	1.25	0.25	1.50	
	Unwrapped solid and hollow materials	7.50	1.20	0.25	2.50	
	Solid and hollow instruments in double pack	2.00	0.60	0.25	1.00	
S 134 °C Fast	Unwrapped hollow instruments	2.00	1.50	0.50	-	
	Unwrapped solid instruments	2.00	1.50	0.50	-	
S 134 °C Solid Wrapped	Solid and hollow instruments "B" in single pack	4.00	1.00	0.25	1.50	It is advisable to use the 3-tray configuration
	Unwrapped solid and hollow materials "B"	7.50	1.20	0.50	2.50	
Custom	Unwrapped solid instruments (other load types are possible depending on the user settings)	n.a.	n.a.	n.a.	n.a.	Variable parameters depending on the settings made
Helix/B&D Test	Test device only (without another load)	-	-	-	-	No other load
Vacuum Test	Trays and support only	-	-	-	-	
Vacuum + Helix/B&D Test (can be performed in sequence)	Trays, support and test devices only	-	-	-	-	

-  (*) To set a sterilization time of 5.5 minutes, contact the Technical Service.
- (**) With the activation of modular drying (min), the total cycle time is reduced by between 10 and 15 minutes, depending on the cycle and chamber size considered.
- Single Pre-Vacuum = 1 pre-vacuum; -0.8 bar (see figures in the following pages).
- Fractionated Pre-Vacuum = 3 pre-vacuum; -0.8 bar each (see figures in the following pages).
- Definition of hollow loads in accordance with standard EN 13060:2014 + A1:2018.
- The term "hollow loads" in this manual refers both to "narrow lumen" elements (section 3.18 EN 13060:2014 + A1:2018) and "simple hollow" elements (section 3.30 EN 13060:2014 + A1:2018).
- The term "hollow load B" refers ONLY to "simple hollow" elements (section 3.30 EN 13060:2014 + A1:2018).

12.4. SUMMARY TABLE OF 22 120 V CYCLES

CYCLE DESCRIPTION	NOMINAL VALUES			BASIC CYCLE PARAMETERS					
	Temp. (°C) - Press. (bar)	Maint. time (min)	Cycle type (EN 13060:2014 + A1:2018)	Pre-vacuum (F=fractionated; S=single)	Standard drying (max)	Modular drying (min)	Total cycle time (medium load)**	Max H2O consumption (ml/cycle)	Average energy consumption (kWh/cycle)
B 134 °C Universal	134 2.1	4(*)	B	F	15	9	42	700	0.80
B 134 °C Prion	134 2.1	18	B	F	15	9	56	750	0.90
B 121 °C Universal	121 1.1	20	B	F	15	9	59	750	0.80
S 134 °C Fast	134 2.1	4(*)	S	F	1	-	24	500	0.65
S 134 °C Solid Wrapped	134 2.1	4(*)	S	S	15	9	37	400	0.60
Custom	134 2.1 ----- 121 1.1	4÷30 - 20÷30	n.a.	F/S	5÷30	n.a.	n.a.	n.a.	n.a.
Helix/B&D Test	134 2.1	3.5	-	F	1	-	24	-	-
Vacuum Test	-	-	-	-	-	-	18	-	-
Vacuum + Helix/B&D Test (can be performed in sequence)	-	-	-	-	-	-	46	-	-

CYCLE DESCRIPTION	STERILIZABLE MATERIALS					NOTES
	TYPE	MAX TOTAL MASS (kg)	MAX MASS PER TRAY (kg)	MAX MASS PER ITEM (kg)	MAX MODULAR DRYING TOTAL MASS (kg)	
B 134 °C Universal	Unwrapped porous materials	1.20	0.40	0.30	0.50	For wrapped materials and instruments (single and double pack), it is advisable to use the 3-tray configuration
	Porous materials in single pack	1.00	0.30	0.25	0.40	
	Porous materials in double pack	0.75	0.25	0.20	0.30	
	Solid and hollow materials in single pack	4.00	1.25	0.25	1.50	
	Unwrapped solid and hollow materials	7.50	1.20	0.25	2.50	
	Solid and hollow instruments in double pack	2.00	0.60	0.25	1.00	
B 134 °C Prion	Unwrapped porous materials	1.20	0.40	0.30	0.50	
	Porous materials in single pack	1.00	0.30	0.25	0.40	
	Porous materials in double pack	0.75	0.25	0.20	0.30	
	Solid and hollow materials in single pack	4.00	1.25	0.25	1.50	
	Unwrapped solid and hollow materials	7.50	1.20	0.25	2.50	
	Solid and hollow instruments in double pack	2.00	0.60	0.25	1.00	
B 121 °C Universal	Unwrapped porous materials	1.20	0.40	0.30	0.50	

CYCLE DESCRIPTION	STERILIZABLE MATERIALS					NOTES
	TYPE	MAX TOTAL MASS (kg)	MAX MASS PER TRAY (kg)	MAX MASS PER ITEM (kg)	MAX MODULAR DRYING TOTAL MASS (kg)	
	Porous materials in single pack	1.00	0.30	0.25	0.40	
	Porous materials in double pack	0.75	0.25	0.20	0.30	
	Solid and hollow materials in single pack	4.00	1.25	0.25	1.50	
	Unwrapped solid and hollow materials	7.50	1.20	0.25	2.50	
	Solid and hollow instruments in double pack	2.00	0.60	0.25	1.00	
S 134 °C Fast	Unwrapped hollow instruments	2.00	1.50	0.50	-	
	Unwrapped solid instruments	2.00	1.50	0.50	-	
S 134 °C Solid Wrapped	Solid and hollow instruments "B" in single pack	4.00	1.00	0.25	1.50	It is advisable to use the 3-tray configuration
	Unwrapped solid and hollow materials "B"	7.50	1.20	0.50	2.50	
Custom	Unwrapped solid instruments (other load types are possible depending on the user settings)	n.a.	n.a.	n.a.	n.a.	Variable parameters depending on the settings made
Helix/B&D Test	Test device only (without another load)	-	-	-	-	No other load
Vacuum Test	Trays and support only	-	-	-	-	
Vacuum + Helix/B&D Test (can be performed in sequence)	Trays, support and test devices only	-	-	-	-	

-  (*) To set a sterilization time of 5.5 minutes, contact the Technical Service.
- (**) With the activation of modular drying (min), the total cycle time is reduced by between 10 and 15 minutes, depending on the cycle and chamber size considered.
- Single Pre-Vacuum = 1 pre-vacuum; -0.8 bar (see figures in the following pages).
- Fractionated Pre-Vacuum = 3 pre-vacuum; -0.8 bar each (see figures in the following pages).
- Definition of hollow loads in accordance with standard EN 13060:2014 + A1:2018.
- The term "hollow loads" in this manual refers both to "narrow lumen" elements (section 3.18 EN 13060:2014 + A1:2018) and "simple hollow" elements (section 3.30 EN 13060:2014 + A1:2018).
- The term "hollow load B" refers ONLY to "simple hollow" elements (section 3.30 EN 13060:2014 + A1:2018).

12.5. SUMMARY TABLE OF 28 220 V - 240 V CYCLES

CYCLE DESCRIPTION	NOMINAL VALUES			BASIC CYCLE PARAMETERS					
	Temp. (°C) - Press. (bar)	Maint. time (min)	Cycle type (EN 13060:2014 + A1:2018)	Pre-vacuum (F=fractionated; S=single)	Standard drying (max)	Modular drying (min)	Total cycle time (medium load)**	Max H2O consumption (ml/cycle)	Average energy consumption (kWh/cycle)
B 134 °C Universal	134 2.1	4(*)	B	F	17	11	52	900	0.80
B 134 °C Prion	134 2.1	18	B	F	17	11	66	950	1.00
B 121 °C Universal	121 1.1	20	B	F	17	11	63	950	0.90
S 134 °C Fast	134 2.1	4(*)	S	F	1	-	27	600	0.65
S 134 °C Solid Wrapped	134 2.1	4(*)	S	S	17	11	41	500	0.70
Custom	134 2.1 ----- 121 1.1	4÷30 - 20÷30	n.a.	F/S	5÷30	n.a.	n.a.	n.a.	n.a.
Helix/B&D Test	134 2.1	3.5	-	F	1	-	28	-	-
Vacuum Test	-	-	-	-	-	-	19	-	-
Vacuum + Helix/B&D Test (can be performed in sequence)	-	-	-	-	-	-	51	-	-

CYCLE DESCRIPTION	STERILIZABLE MATERIALS					NOTES
	TYPE	MAX TOTAL MASS (kg)	MAX MASS PER TRAY (kg)	MAX MASS PER ITEM (kg)	MAX MODULAR DRYING TOTAL MASS (kg)	
B 134 °C Universal	Unwrapped porous materials	1.20	0.40	0.30	0.60	For wrapped materials and instruments (single and double pack), it is advisable to use the 3-tray configuration
	Porous materials in single pack	1.00	0.30	0.25	0.50	
	Porous materials in double pack	0.75	0.25	0.20	0.40	
	Solid and hollow materials in single pack	4.00	1.25	0.25	2.00	
	Unwrapped solid and hollow materials	7.50	1.20	0.25	4.00	
	Solid and hollow instruments in double pack	2.00	0.60	0.25	1.25	
B 134 °C Prion	Unwrapped porous materials	1.20	0.40	0.30	0.60	
	Porous materials in single pack	1.00	0.30	0.25	0.50	
	Porous materials in double pack	0.75	0.25	0.20	0.40	
	Solid and hollow materials in single pack	4.00	1.25	0.25	2.00	
	Unwrapped solid and hollow materials	7.50	1.20	0.25	4.00	
	Solid and hollow instruments in double pack	2.00	0.60	0.25	1.25	
B 121 °C Universal	Unwrapped porous materials	1.20	0.40	0.30	0.60	

CYCLE DESCRIPTION	STERILIZABLE MATERIALS					NOTES
	TYPE	MAX TOTAL MASS (kg)	MAX MASS PER TRAY (kg)	MAX MASS PER ITEM (kg)	MAX MODULAR DRYING TOTAL MASS (kg)	
	Porous materials in single pack	1.00	0.30	0.25	0.50	
	Porous materials in double pack	0.75	0.25	0.20	0.40	
	Solid and hollow materials in single pack	4.00	1.25	0.25	2.00	
	Unwrapped solid and hollow materials	7.50	1.20	0.25	4.00	
	Solid and hollow instruments in double pack	2.00	0.60	0.25	1.25	
S 134 °C Fast	Unwrapped hollow instruments	2.00	1.50	0.50	-	
	Unwrapped solid instruments	2.00	1.50	0.50	-	
S 134 °C Solid Wrapped	Solid and hollow instruments "B" in single pack	4.00	1.00	0.25	1.50	It is advisable to use the 3-tray configuration
	Unwrapped solid and hollow materials "B"	7.50	1.20	0.50	2.50	
Custom	Unwrapped solid instruments (other load types are possible depending on the user settings)	n.a.	n.a.	n.a.	n.a.	Variable parameters depending on the settings made
Helix/B&D Test	Test device only (without another load)	-	-	-	-	No other load
Vacuum Test	Trays and support only	-	-	-	-	
Vacuum + Helix/B&D Test (can be performed in sequence)	Trays, support and test devices only	-	-	-	-	



(*) To set a sterilization time of 5.5 minutes, contact the Technical Service.

(**) With the activation of modular drying (min), the total cycle time is reduced by between 10 and 15 minutes, depending on the cycle and chamber size considered.

Single Pre-Vacuum = 1 pre-vacuum; -0.8 bar (see figures in the following pages).

Fractionated Pre-Vacuum = 3 pre-vacuum; -0.8 bar each (see figures in the following pages).

Definition of hollow loads in accordance with standard EN 13060:2014 + A1:2018.

The term "hollow loads" in this manual refers both to "narrow lumen" elements (section 3.18 EN 13060:2014 + A1:2018) and "simple hollow" elements (section 3.30 EN 13060:2014 + A1:2018).

The term "hollow load B" refers ONLY to "simple hollow" elements (section 3.30 EN 13060:2014 + A1:2018).

12.6. SUMMARY TABLE OF 28 120 V CYCLES

CYCLE DESCRIPTION	NOMINAL VALUES			BASIC CYCLE PARAMETERS					
	Temp. (°C) - Press. (bar)	Maint. time (min)	Cycle type (EN 13060:2014 + A1:2018)	Pre-vacuum (F=fractionated; S=single)	Standard drying (max)	Modular drying (min)	Total cycle time (medium load)**	Max H2O consumption (ml/cycle)	Average energy consumption (kWh/cycle)
B 134 °C Universal	134 2.1	4(*)	B	F	17	11	52	900	0.80
B 134 °C Prion	134 2.1	18	B	F	17	11	66	950	1.00
B 121 °C Universal	121 1.1	20	B	F	17	11	63	950	0.90
S 134 °C Fast	134 2.1	4(*)	S	F	1	-	27	600	0.65
S 134 °C Solid Wrapped	134 2.1	4(*)	S	S	17	11	41	500	0.70
Custom	134 2.1 ----- 121 1.1	4÷30 - 20÷30	n.a.	F/S	5÷30	n.a.	n.a.	n.a.	n.a.
Helix/B&D Test	134 2.1	3.5	-	F	1	-	28	-	-
Vacuum Test	-	-	-	-	-	-	19	-	-
Vacuum + Helix/B&D Test (can be performed in sequence)	-	-	-	-	-	-	51	-	-

CYCLE DESCRIPTION	STERILIZABLE MATERIALS					NOTES
	TYPE	MAX TOTAL MASS (kg)	MAX MASS PER TRAY (kg)	MAX MASS PER ITEM (kg)	MAX MODULAR DRYING TOTAL MASS (kg)	
B 134 °C Universal	Unwrapped porous materials	1.20	0.40	0.30	0.60	For wrapped materials and instruments (single and double pack), it is advisable to use the 3-tray configuration
	Porous materials in single pack	1.00	0.30	0.25	0.50	
	Porous materials in double pack	0.75	0.25	0.20	0.40	
	Solid and hollow materials in single pack	4.00	1.25	0.25	2.00	
	Unwrapped solid and hollow materials	7.50	1.20	0.25	4.00	
	Solid and hollow instruments in double pack	2.00	0.60	0.25	1.25	
B 134 °C Prion	Unwrapped porous materials	1.20	0.40	0.30	0.60	
	Porous materials in single pack	1.00	0.30	0.25	0.50	
	Porous materials in double pack	0.75	0.25	0.20	0.40	
	Solid and hollow materials in single pack	4.00	1.25	0.25	2.00	
	Unwrapped solid and hollow materials	7.50	1.20	0.25	4.00	
	Solid and hollow instruments in double pack	2.00	0.60	0.25	1.25	
B 121 °C Universal	Unwrapped porous materials	1.20	0.40	0.30	0.60	

CYCLE DESCRIPTION	STERILIZABLE MATERIALS					NOTES
	TYPE	MAX TOTAL MASS (kg)	MAX MASS PER TRAY (kg)	MAX MASS PER ITEM (kg)	MAX MODULAR DRYING TOTAL MASS (kg)	
	Porous materials in single pack	1.00	0.30	0.25	0.50	
	Porous materials in double pack	0.75	0.25	0.20	0.40	
	Solid and hollow materials in single pack	4.00	1.25	0.25	2.00	
	Unwrapped solid and hollow materials	7.50	1.20	0.25	4.00	
	Solid and hollow instruments in double pack	2.00	0.60	0.25	1.25	
S 134 °C Fast	Unwrapped hollow instruments	2.00	1.50	0.50	-	
	Unwrapped solid instruments	2.00	1.50	0.50	-	
S 134 °C Solid Wrapped	Solid and hollow instruments "B" in single pack	4.00	1.00	0.25	1.50	It is advisable to use the 3-tray configuration
	Unwrapped solid and hollow materials "B"	7.50	1.20	0.50	2.50	
Custom	Unwrapped solid instruments (other load types are possible depending on the user settings)	n.a.	n.a.	n.a.	n.a.	Variable parameters depending on the settings made
Helix/B&D Test	Test device only (without another load)	-	-	-	-	No other load
Vacuum Test	Trays and support only	-	-	-	-	
Vacuum + Helix/B&D Test (can be performed in sequence)	Trays, support and test devices only	-	-	-	-	

-  (*) To set a sterilization time of 5.5 minutes, contact the Technical Service.
- (**) With the activation of modular drying (min), the total cycle time is reduced by between 10 and 15 minutes, depending on the cycle and chamber size considered.
- Single Pre-Vacuum = 1 pre-vacuum; -0.8 bar (see figures in the following pages).
- Fractionated Pre-Vacuum = 3 pre-vacuum; -0.8 bar each (see figures in the following pages).
- Definition of hollow loads in accordance with standard EN 13060:2014 + A1:2018.
- The term "hollow loads" in this manual refers both to "narrow lumen" elements (section 3.18 EN 13060:2014 + A1:2018) and "simple hollow" elements (section 3.30 EN 13060:2014 + A1:2018).
- The term "hollow load B" refers ONLY to "simple hollow" elements (section 3.30 EN 13060:2014 + A1:2018).

PRESSURE, TIME AND TEMPERATURE
According to EN 13060:2014 + A1:2018 for operating cycles

Cycles B at 134°C

EN 13060:2014 + A1:2018		Time (minutes)	Min temperature	Max temperature	Min pressure (bar)	Max pressure (bar)
1	CS	---	---	---	---	---
t1	1PV	---	---	---	-0.81	-0.79
t2	1PP	---	---	---	+0.67	+0.73
t3	2PV	---	---	---	-0.79	-0.77
t4	2PP	---	---	---	+0.67	+0.73
t5	3PV	---	---	---	-0.79	-0.77
t6	SS	4/ 5.5/ 10	+134	+137	+2.04	+2.40
t7	SE	4/ 5.5/ 10	+134	+137	+2.04	+2.40
t8	DS	---	---	---	-0.76	-0.74
t9	DE	---	---	---	---	---
2	CE	---	---	---	-0.02	+0.02

Cycles B at 121°C

EN 13060:2014 + A1:2018		Time (minutes)	Min temperature	Max temperature	Min pressure (bar)	Max pressure (bar)
1	CS	---	---	---	---	---
t1	1PV	---	---	---	-0.81	-0.79
t2	1PP	---	---	---	+0.67	+0.73
t3	2PV	---	---	---	-0.79	-0.77
t4	2PP	---	---	---	+0.67	+0.73
t5	3PV	---	---	---	-0.79	-0.77
t6	SS	20	+121	+124	+1.05	+1.31
t7	SE	20	+121	+124	+1.05	+1.31
t8	DS	---	---	---	-0.76	-0.74
t9	DE	---	---	---	---	---
2	CE	---	---	---	-0.02	+0.02

Cycle S 134 °C Fast

EN 13060:2014 + A1:2018		Time (minutes)	Min temperature	Max temperature	Min pressure (bar)	Max pressure (bar)
1	CS	---	---	---	---	---
t1	1PV	---	---	---	-0.74	-0.76
t2	1PP	---	---	---	+0.25	+0.30
t3	2PV	---	---	---	-0.79	-0.77
t4	2PP	---	---	---	+0.25	+0.30
t5	3PV	---	---	---	-0.79	-0.77
t6	SS	4/ 5.5/ 10	+134	+137	+2.04	+2.40
t7	SE	4/ 5.5/ 10	+134	+137	+2.04	+2.40
t8	DS	---	---	---	-0.76	-0.74
t9	DE	---	---	---	---	---
2	CE	---	---	---	-0.02	+0.02

Cycle S 134 °C Solid

EN 13060:2014 + A1:2018		Time (minutes)	Min temperature	Max temperature	Min pressure (bar)	Max pressure (bar)
1	CS	---	---	---	---	---
t1	1PV	---	---	---	-0.81	-0.72
t2	1PP	---	---	---	---	---
t3	2PV	---	---	---	---	---
t4	2PP	---	---	---	---	---
t5	3PV	---	---	---	---	---
t6	SS	4	+134	+137	+2.05	+2.31
t7	SE	4	+134	+137	+2.05	+2.31
t8	DS	---	---	---	-0.68	-0.62
t9	DE	---	---	---	---	---
2	CE	---	---	---	-0.02	+0.02

12.7. STERILIZATION PROGRAM DIAGRAM

PROGRAM
B 134 °C Universal
134°C – 4' 00"

A FRACTIONATED PRE-VACUUM
B PROCESS
C VACUUM DRYING

PROGRAM
B 134 °C Prion
134°C – 18' 00"

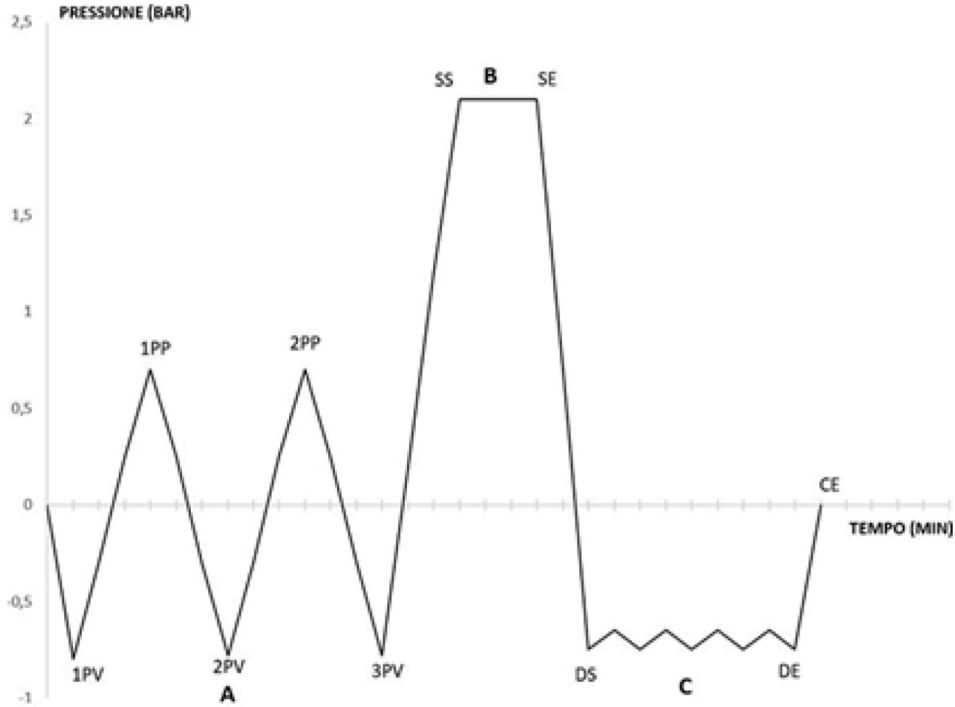

PROGRAM
121 °C Universal
121°C – 20' 00"

A FRACTIONATED PRE-VACUUM
B PROCESS
C VACUUM DRYING

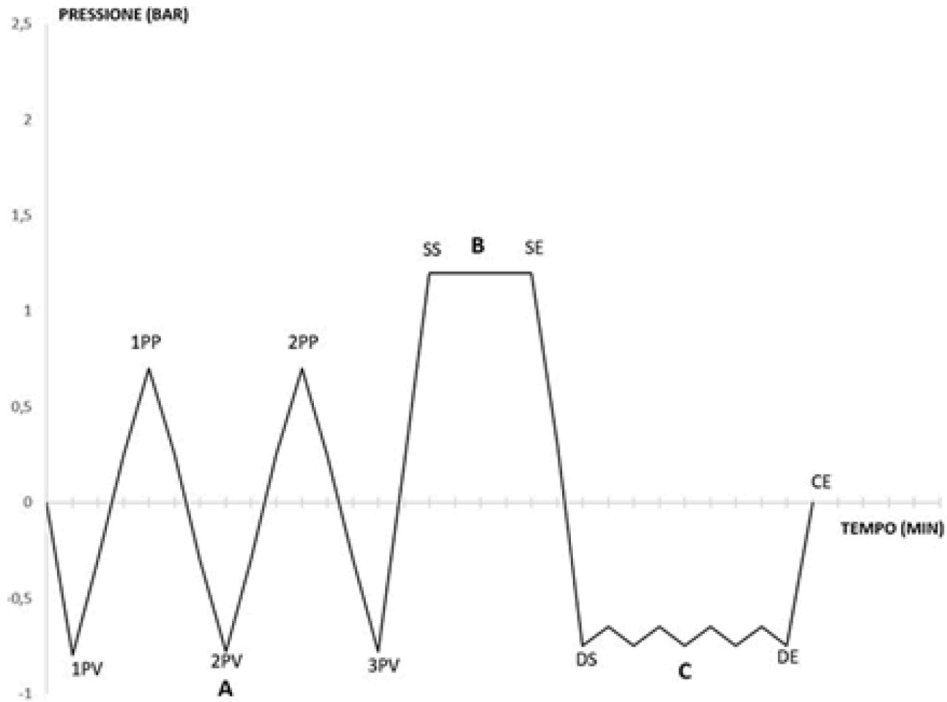

PROGRAM **A** FRACTIONATED PRE-VACUUM
S 134 °C Fast **B** PROCESS
134°C – 4'00" **C** VACUUM DRYING

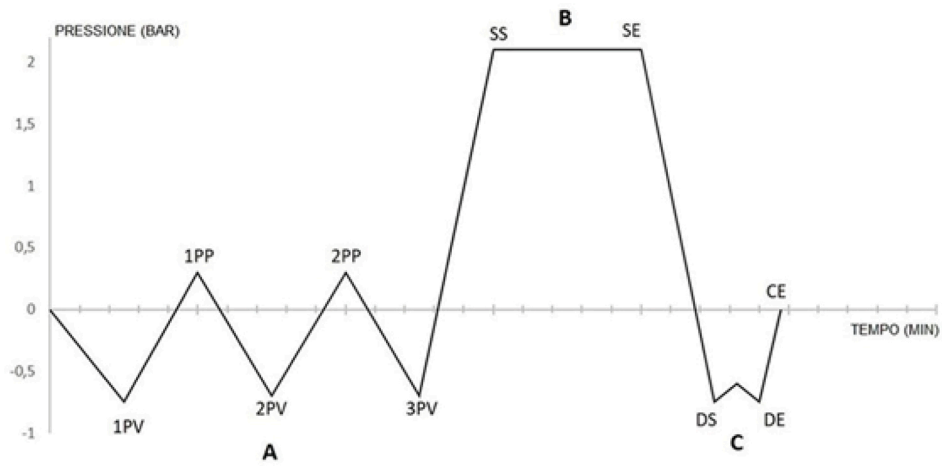

PROGRAM **A** SINGLE PRE-VACUUM
S 134 °C Solid Wrapped **B** PROCESS
134°C – 4'00" **C** VACUUM DRYING

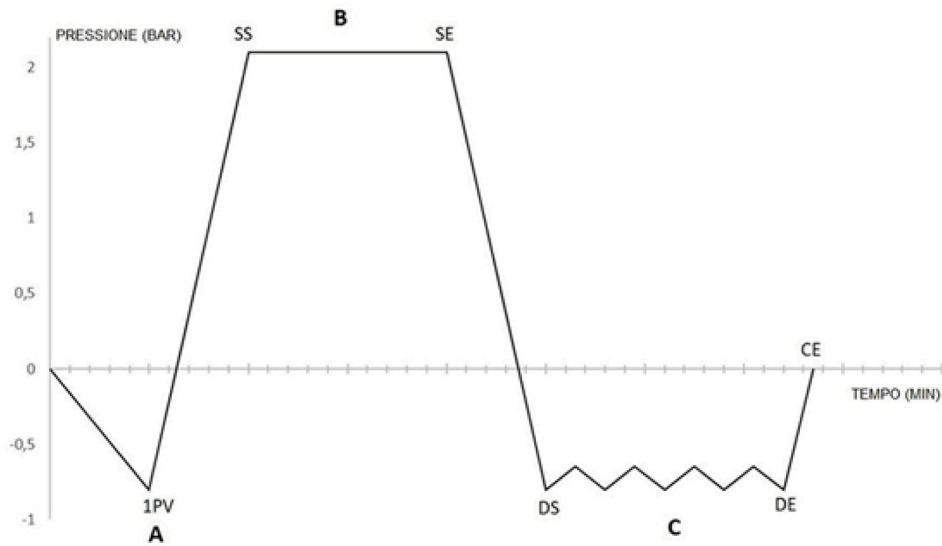

12.8. TEST PROGRAM DIAGRAM

PROGRAM A FRACTIONATED PRE-VACUUM
Helix/B&D Test B PROCESS
134°C – 3'30" C VACUUM DRYING

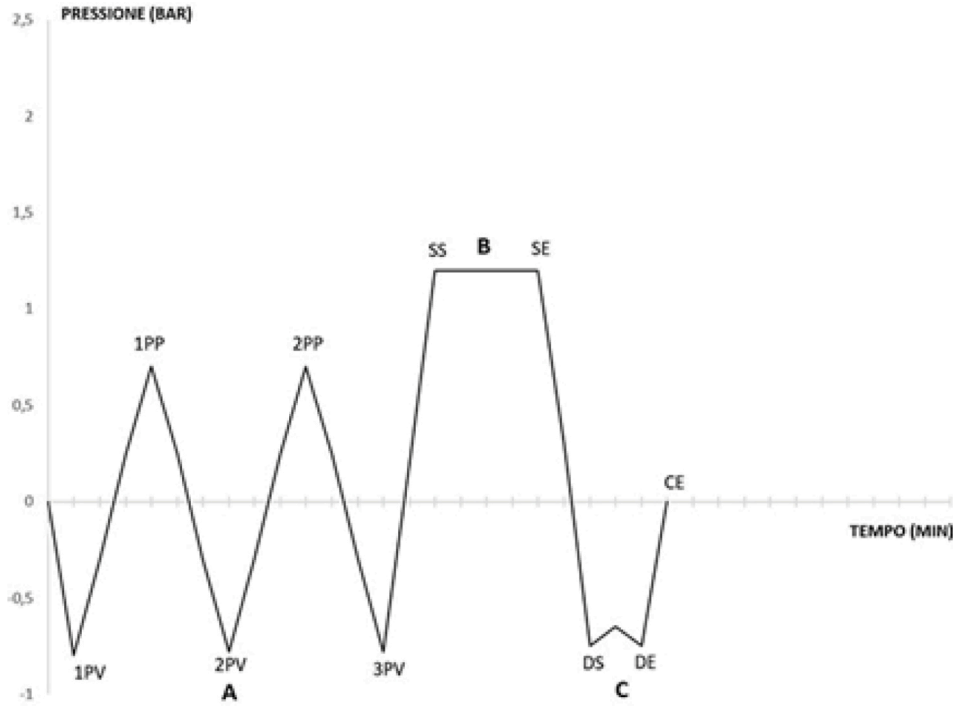

PROGRAM L INTERMEDIATE CONDITION TO CONTINUE THE TEST
Vacuum Test M FINAL CONDITION TO PASS THE TEST
-0.80 bar N VACUUM PHASE
O STANDBY
P LOSS MEASUREMENT

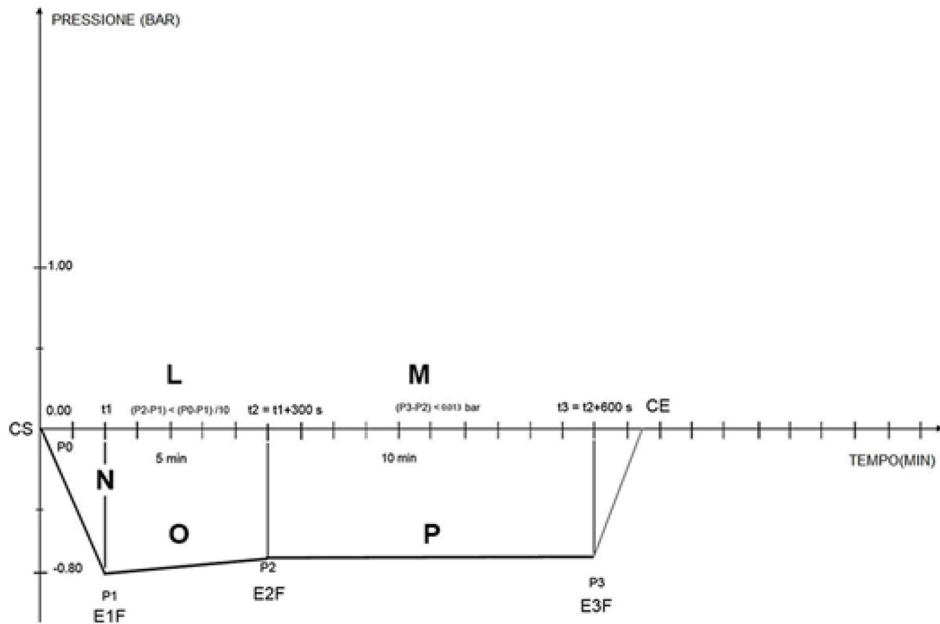

12.9. EXAMPLES OF PRINTED REPORTS

(WITH OPTIONAL PRINTER)

PROGRAM PRINTING (STANDARD)

Model
S/N
Ver. SW
Counter 0007/0015
Selection 134 °C SOLID
Temperature 134 °C
Pressure 2.10 bar
Process time 4 min
Stand-by LOW
Pre-vacuum SINGLE
Drying FAST

CYCLE START 01/02/11
12:14

Time	C	bar
00:01	CS	079.4 +0.00
02:02	1PV	093.7 -0.80
05:48	ET	135.6 +2.15
06:02	SS	135.9 +2.17
07:02		135.6 +2.14
08:02		135.5 +2.14
09:02		135.4 +2.14
10:02	SE	135.5 +2.15
10:37	DS	104.1 +0.00
11:41	SPD	047.5 -0.90
16:08	DE	047.6 -0.84
17:12	CE	084.6 -0.04
06:32	MAX	136.0
09:59	MIN	135.4

Drying Pulses 01
CYCLE END 01/02/11
12:36

STERILIZATION: POSITIVE

PROGRAM PRINTING HELIX/BD TEST

Model
S/N
Ver. SW
Counter 0011/0019
Selection HELIX TEST
Temperature 134 °C
Pressure 2.10 bar
Process time 3.5 min
CYCLE START 01/02/11
16:38

Time	C	bar
00:01	CS	076.4 +0.00
02:06	1PV	089.3 -0.89
04:35	1PP	120.4 +0.99
05:45	2PV	062.5 -0.78
07:02	2PP	120.2 +0.97
08:15	3PV	061.1 -0.79
11:00	..	135.6 +2.15
11:14	..	136.0 +2.17
12:14		135.6 +2.14
13:14		135.6 +2.15
14:14		135.5 +2.14
14:45	..	135.4 +2.14
15:20	..	111.5 +0.00
16:34	..	047.8 -0.89
18:21	..	059.5 -0.86
19:21	..	075.4 -0.50
20:06	CE	078.7 -0.04
12:33	MAX	136.0
14:44	MIN	135.4

Drying pulses 01
CYCLE END 01/02/11
17:01

HELIX TEST COMPLETE
Please attach the indicator hereunder

PROGRAM PRINTING VACUUM TEST

Model
S/N
Ver. SW
Counter 0011/0019
Selection VACUUM TEST

CYCLE START 01/02/11
11:37

Time	C	bar
00:00	CS	035.0 +0.00
01:39	E1F	037.4 -0.80
6:39	E2F	038.4 -0.79
22:39	E3F	042.0 -0.79
23:54	CE	045.5 -0.01

CYCLE END 01/02/11
12:01

VACUUM TEST: POSITIVE

Model
S/N
Ver. SW
Counter 0007/0015
Selection 134 °C UNIVERSAL
Temperature 134 °C
Pressure 2.10 bar
Process time 4 min
Stand-by HIGH
Pre-vacuum FRACTIONATED
Drying STANDARD

CYCLE START 01/02/10
09:52

Time	C	bar
00:01	CS	075.1 -0.00
01:57	1PV	047.5 -0.80
04:53	1PP	120.5 +1.00
07:00	2PV	061.1 -0.80
09:15	2PP	120.4 +0.98
11:22	3PV	061.1 -0.80
15:04	ET	135.5 +2.15
15:19	SS	135.9 +2.17
16:19		135.4 +2.14
17:18		135.5 +2.15
18:19		135.4 +2.14
19:19	SE	135.5 +2.15
19:53	DS	104.4 +0.00
20:57	SPD	048.4 -0.90
26:55	EPD	094.9 -0.86
29:15	DE	112.6 -0.47
29:43	CE	115.8 -0.04
16:20	MAX	135.9
18:11	MIN	135.4

Drying Pulses 05
CYCLE END 01/02/11
10:28

STERILIZATION: POSITIVE

 The text printed on the receipt remains for a couple of years, if correctly stored (away from any source of heat and in a cool, dry place). It is recommended that you make a copy of the receipt, which is printed on thermal paper.

13. APPENDIX - MAINTENANCE

In addition to correct use, the user needs to perform ordinary maintenance in order to guarantee safe, efficient operation over the device's entire life.



Always use personal protective equipment.



For better quality of maintenance, supplement routine checks with regular periodic check-ups that can be performed by Technical Service Department (see Appendix).

It is also fundamental to perform a **periodic sterilizer validation**, i.e. a check of process thermo-dynamic parameters and their comparison with the reference values detected by duly calibrated tools. Refer to 'Sterilizer periodic validation' in the next part of the Appendix.

The ordinary maintenance described below consists in easy manual operations and preventive interventions involving simple instruments.



In the event of replacement of components or parts of the device, request and/or use original spare parts only.

13.1. ORDINARY MAINTENANCE PROGRAM

The table summarizes the maintenance interventions required to maintain the sterilizer in good working order.

In case of **heavy use** we recommend to **shorten** maintenance intervals:

DAILY	Clean the gasket and the internal part of the door Clean external surfaces
WEEKLY	Clean the sterilization chamber and its additional components Cleaning/disinfecting external surfaces Clean/disinfect filling/drainage tanks
UPON WATER FILLING OPERATION	Clean/disinfect filling/drainage tanks
UPON FILTER REPLACEMENT	
PERIODICALLY	See <i>Scheduled Maintenance Messages</i>
EVERY 3 YEARS / 3000 CYCLES	General service (see <i>Description of maintenance interventions</i>)

13.2. SCHEDULED MAINTENANCE MESSAGES

The sterilizer periodically displays warning messages relevant to “routine” maintenance operations that must be carried out in order to ensure the proper operation of the device.

Press **(A)** to confirm that the required maintenance operation has been completed.

Press **(B)** to postpone the operation.

In this case, the warning message will reappear the next time the sterilizer is used.

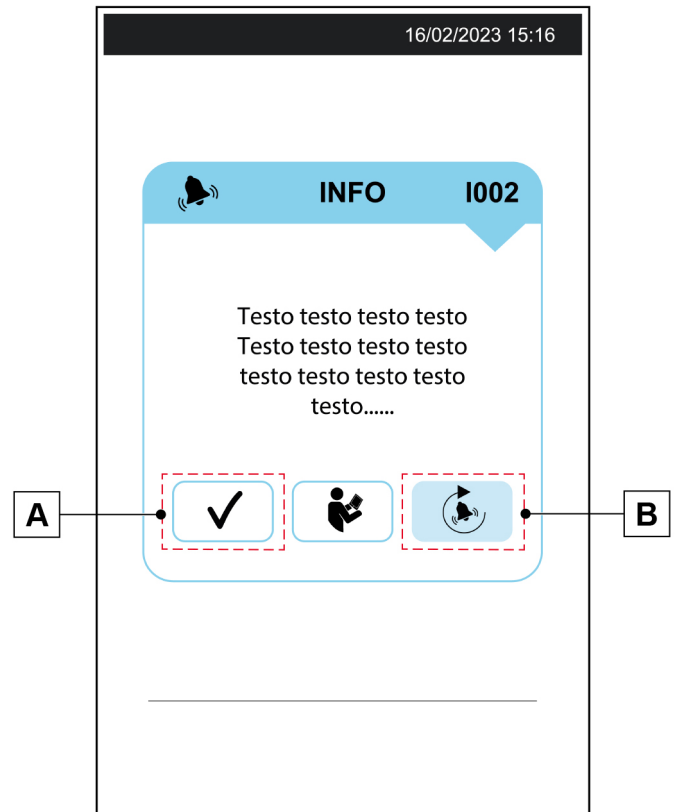

Warnings are shown to the user with the following frequency, which can be set on a cycle basis or on a day basis*:

WARNING MESSAGE

- BOILER FILTER CLEANING – 250 cycles or 120 days
- DOOR LOCK LUBRICATION – 1,000 cycles or 365 days
- DUST FILTER CLEANING – 500 cycles or 180 days
- BACTERIOLOGICAL FILTER REPLACEMENT – 500 cycles or 180 days
- BOILER GASKET REPLACEMENT – 1,000 cycles or 365 days
- GENERAL SERVICE – 3,000 cycles or 1,200 days

 * Cycle-based default setting; to change the setting contact the Technical Service Department.
 A regular maintenance is essential to achieve the best performance of the device.
 Periodically, a message will be displayed requesting that the above maintenance operations are performed.
 For further information or in case of doubt, contact the technical service: if they have performed regular maintenance on the device, the technician might have already carried out some of these operations (e.g. >Replacement of the bacteriological filter or of the gasket).

Always keep in mind the following **general warnings**:

- Do not wash the sterilizer with direct jets of water, neither under pressure nor sprinkled. Seepage into electrical and electronic components could damage the functioning of the device or its internal parts, even irreparably;
- Do not use abrasive cloths, metal brushes (or other aggressive materials) or products for metal cleaning, both solid and liquid, to clean the device or the sterilization chamber;
- Do not use unsuitable chemical products or disinfectants to clean the sterilization chamber. In fact, these products can cause damages, even irreparably;
- Do not allow limescale or residues of other substances to accumulate in the sterilization chamber, on the door and on the gasket, but remove them periodically. In fact, such residues may damage these parts, besides compromising the operation of the hydraulic circuit components.

 The formation of white spots on the base of the internal wall of the chamber means that you are using poor quality demineralised water.



Before performing ordinary maintenance, make sure that the power cord plug is removed from the mains socket. If this is not possible, move the external switch of the device's power supply line to Off. If the external switch is distant or not visible to the maintainer, place a "work in progress" sign on the switch, after turning it off.

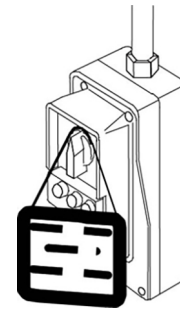

13.3. DESCRIPTION OF MAINTENANCE OPERATIONS

Let's now look at the various operations to be carried out.

13.3.1. GASKET AND PORTHOLE CLEANING

To eliminate any traces of limestone, clean the gasket of the chamber and the door porthole with a clean cotton cloth soaked in a soft solution of water and vinegar (or a similar product, checking the contents on the label before using).

Dry the surfaces and remove any residues before using the device.

13.3.2. CLEANING THE STERILIZATION CHAMBER AND ITS ADDITIONAL COMPONENTS

Clean the sterilization chamber, support and trays (and internal surfaces in general) with a clean cotton cloth soaked in water and, possibly, the addition of a small amount of neutral detergent.

Carefully rinse with distilled water, taking care not to leave any type of residue in the chamber or on the additional components.



Do not use pointed or sharp tools to remove scale from the sterilization chamber. Should there be evident deposits, immediately check the quality of the distilled water used (see technical characteristics appendix).

13.3.3. CLEANING AND DISINFECTING EXTERNAL SURFACES

To clean and disinfect the external surfaces, we recommend using STER 1 PLUS or ethyl alcohol diluted with 50% water. Apply product with a soaked cloth, then dry.

As an alternative, we recommend using products containing the following at no more than the given concentration:

- **Ethanol:** maximum concentration 30%.
- **1-Propanol** (n-propanol, propyl alcohol, n-propyl alcohol): maximum concentration 20%.
- **Combination of ethanol and propanol:** maximum concentration 40%.



Do not spray or vaporise any product directly on device surfaces. Flammable liquids.

13.3.4. BOILER FILTER CLEANING

With use it is likely that various residues accumulate in the filter and with time obstruct the lower drain duct.

To clean the filter, open the sterilizer door and remove the cap.

Loosen the union that contains the filter.

Remove the filter from its support and thoroughly clean it under a jet of running water, if necessary using a sharp tool to remove any large foreign bodies (if possible use a jet of compressed air).

If it is **impossible** to recover the filter, replace it with a new one.

Refit everything operating in reverse order and making sure to screw the union in such a way that the drain holes are positioned **at the level of the boiler wall**.



Properly fit the filter in its housing. A partial fitting may damage the component.

13.3.5. DOOR LOCK LUBRICATION

Remove any residue with a clean cloth.
Lubricate the inside of the door catch on the sterilizer door with a film of the grease provided (as shown in the figure).



Wear single-use gloves before application.

Essentially, the lubricant is not irritant to the skin; nevertheless, it may cause unpleasant effects if it accidentally comes into contact with eyes.

In case of contact with eyes, rinse with plenty of water.

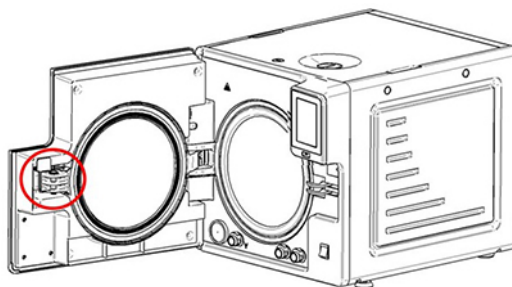

13.3.6. DUST FILTER CLEANING

Remove the dust filter (A) from the lower part of the autoclave, thoroughly rinse it with water and dry it before refitting it.

The filter can be cleaned using a jet of compressed air, making sure not to disperse any dust into the environment.

- A Dust filter
- B Bacteriological filter

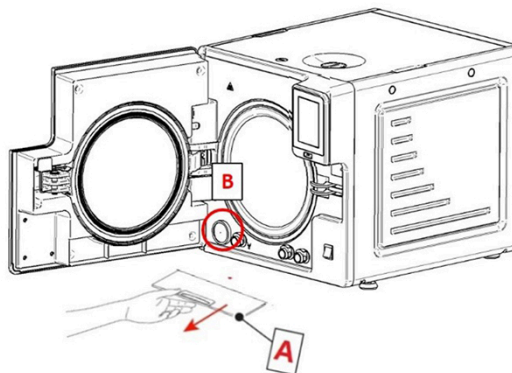

13.3.7. BACTERIOLOGICAL FILTER REPLACEMENT

When filter maintenance is due or every time you notice visible clogging of the filter (indicated by the filter markedly turning grey), unscrew the bacteriological filter from its support and replace it with a new one, screwing it fully down on the union.



A spare bacteriological filter is provided with the device.

If you need spare parts of this component, refer to technical assistance [appendix](#).

13.3.8. CLEANING AND DISINFECTION OF FILTER, INTEGRATED DEMINERALISATION FILTER AND WATER TANKS

Remove the upper panel:

1. turning the lock (A) anti-clockwise;
2. lifting it from the side grips.

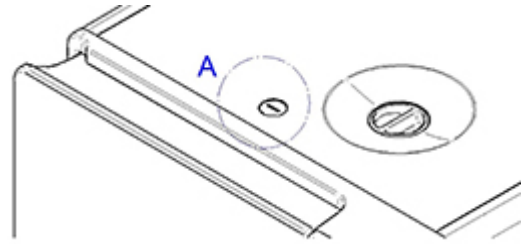

Clean and disinfect filters and internal walls only of the tank with a disposable wipe/cloth soaked in ethyl alcohol 70%.

 Do not use 70% alcohol to disinfect the other plastic surfaces.

Empty the tanks containing the autoclave filling and discharge water, remove any deposits around the filters (highlighted in red) at the bottom of the tanks (see figure) and on the integrated demineralisation filter (if present).

After removing and cleaning the filters, wipe the inside of the tanks with a cloth soaked in ethyl alcohol 70% and clean thoroughly. After cleaning the filters, refit them inside the tanks.

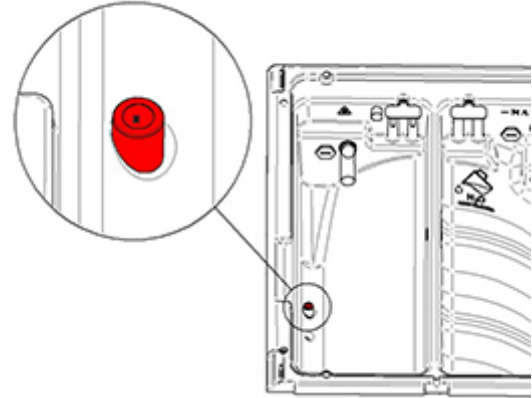

13.3.9. REPLACEMENT OF THE INTEGRATED DEMINERALISATION FILTER

When the special alarms indicate the production of demineralised water with conductivity levels above the allowed threshold (20 μ S/cm), the ion-exchange resin cartridge must be replaced:

- Turn the sterilizer off;
- Remove the upper cover by turning the lock (key socket) anti-clockwise;
- Empty the load tank of the autoclave;
- Remove the cartridge by first turning the cartridge locking latch;
- Replace the cartridge according to the initial installation procedure (see chapter INTEGRATED DEMINERALISATION FILTER).
- Position the upper cover back in place by turning the lock (key socket) clockwise.

 When moving the used demineralisation filter, water may come out of the cartridge.

13.3.10. BOILER GASKET REPLACEMENT

It is advisable to have the door gasket replaced by an authorised technician, therefore contact Technical Service (see **APPENDIX – TECHNICAL SERVICE**).

13.4. PERIODIC STERILIZER VALIDATION

As happens with all devices, it is possible, and sometimes inevitable, to have a decrease in performance and the effectiveness of components along their lifespan, in a period of time dependent on its frequency of use.

To guarantee the safety of the process over time, it is periodically (possibly annually) necessary to **verify** the **thermodynamic process parameters** (pressure and temperature), to check if they continue to remain within allowed limits or not.

The requalification of the sterilizer's performance is the **responsibility of the user** of the product.

The reference European standards **EN 17665** (Sterilization of the medical devices - Method for the validation and systematic control of the steam sterilization) and **EN 556** (Sterilization of the medical devices – Requirements for the medical devices marked with "STERILE" indication) supply an effective guide tool for carrying out the verifications on the steam sterilizers.

Since, in addition to specific experience and training, these controls require the use of special equipment (high-precision sensors and probes, data loggers, dedicated software, etc.) suitably verified and calibrated, it is necessary to contact a company specializing in these activities.

 *Customer support department (see **Appendix**) is available to provide any information relative to the periodic validation of steam sterilizers.*

13.5. DEVICE SERVICE LIFE

Water steam sterilizer service life is of 10 years (average use: 5 cycles/day, for 220 days/year). For normal use, it is expected that the device is used and maintained according to the instructions provided by the manufacturer.

13.6. END-OF-LIFE DISPOSAL

According to Directive 2012/19/EU concerning waste disposal, the units must not be disposed of as municipal waste, but must be separated. When purchasing a new device of an equivalent type, one for one, the device that has come to the end of its lifetime should be returned to the dealer for disposal.

As regards reuse, recycling and other forms of recovery of the above mentioned waste, the manufacturer carries out the functions defined in the individual national legislations.

Appropriate differentiated waste collection for subsequent recycling treatment and environmentally friendly disposal contributes to preventing possible negative effects on the environment and health and encourages recycling of the materials of which the device is made up. The symbol indicating separate collection for electrical and electronic equipment consists of the crossed out bin marked on the device.



Under national legislation, fines can be imposed if the product is disposed in an illegal manner.

14. APPENDIX - GENERAL PROBLEMS



If while using the device a problem or an alarm occurs, this **DOES NOT** mean that the device is out of order. It may not, in fact, be related to a breakdown but, more probably to an anomalous situation, often merely transitory (such as a blackout), or incorrect use.

In any case, it is important to first identify the cause of the failure and then take suitable corrective actions, either autonomously or with the intervention of the **Technical Service Department** (see Appendix).

For this purpose, below, we provide instructions for diagnosing and resolving general problems, in addition to a precise description of the alarm codes, their meaning and their solution.

14.1. TROUBLESHOOTING

If your sterilizer is not working correctly, please make the following checks before contacting the Technical Service Department:

PROBLEM	POSSIBLE CAUSE	SUGGESTED SOLUTION
The sterilizer does not power-on.	The power cable is not plugged-in.	Plug it in.
	Lack of voltage at the power supply socket.	Check the cause of the lack of voltage at socket and fix it.
	The main switch and/or differential switch are turned to OFF.	Turn the switch to ON.
	The network fuses are blown.	Replace with good fuses of equal nominal value. (See the Summary Table in Appendix, Technical Characteristics).
After pressing START, the sterilization cycle does not start.	The device is preheating.	Wait for the sterilizer to reach the proper operating conditions for starting the program.  <i>Under standard conditions, the Average Heating Time is about 10-15 Minutes.</i>
The safety valve has triggered.	Locking ring loosened. Presence of anomalous overpressure in the chamber.	Check the proper tightening of the milled ring nut of the safety valve.  Let the device cool or use gloves to prevent burns while touching the valve.
Water presence on the sterilizer resting surface.	The water automatic filling system hose (optional) is not correctly connected.	Check the tightness of the fittings and, if necessary, reassemble them more carefully. Check that the hoses are completely inserted on the fittings; check the presence of hose clamps.
	Steam leak from door gasket.	At the end of the cycle clean the gasket and the closing porthole with a dampened cloth. Check the presence of any gasket damage. Perform a new verification cycle.
Excessive humidity on the material and/or instruments at the end of the program.	Excessive load in the sterilization chamber.	Check that the load does not exceed the maximum values permitted. (See the Summary Table in Appendix "Technical Characteristics").
	Load not correctly positioned.	Position the load, in particular the wrapped one, as per the indications. (See Chapter "Preparing the material").
	Wrong selection of the sterilization program.	Choose the sterilization program suitable for the type of material to be treated. (See the Summary Table in the Appendix "Programs").
	Clogged chamber drainage filter.	Clean or replace the drainage filter. (See Appendix "Maintenance").
Traces of oxidation or spots on instruments.	Quality of the instruments not adequate.	Check the quality of instruments, making sure that the material they are made of is suitable to tolerate the steam sterilization.
	Quality of the distilled water not adequate.	Empty the tank and fill it with high-quality distilled water. (See Water supply characteristics in Appendix "Technical characteristics").
	Organic or inorganic residues on the instruments.	Carefully clean the material before subjecting it to the sterilization cycle. (See Chapter "Preparing the material").
	Contact between instruments made of different metals.	Separate instruments made of different metals. (See Chapter "Preparing the material").
	Presence of limescale residues on the wall of the chamber and/or additional components.	Clean the chamber and the additional components as prescribed. (See Appendix "Maintenance").
Blackening of the instruments or damage to the material.	Wrong selection of the sterilization program.	Choose the sterilization program suitable for the type of material to be treated. (See the Summary Table in the Appendix "Programs").

15. APPENDIX - ALARM INDICATION

 If the problem persists, contact the technical service (see [APPENDIX](#)) communicating the sterilizer model and serial number. These data are indicated on the registration plate on the rear side of the device and on the declaration of conformity and can be viewed also by means of the "sterilizer information" command.

Every time an **anomalous condition** occurs during the operation of the sterilizer, an alarm is generated, identified by a **specific code** (consisting of a letter followed by a 3-digit number).

Alarm codes are divided into **three categories**:

E= ERROR

Non-user dependent fault that prevents the cycle from functioning correctly. Problem not resettable by the user, technical assistance required.

Code format: **Exxx (xxx= identification number 000 ÷ 999)**

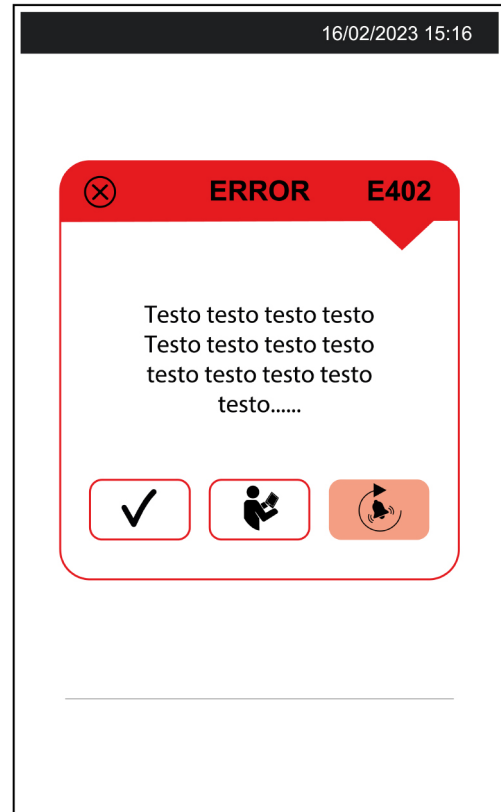

W = WARNING

A fault that does not affect the correct operation of a cycle. Problem normally resettable by the user.

Code format: **Wxxx (xxx= identification number 000 ÷ 999)**



I = INFO

System notifications.

Generally the user can deactivate them via display choice.

Code format: **lxxx (xxx= identification number 000 ÷ 999)**



 *In case of alarm, switch off the device only after having followed the indications displayed and performed the reset (see “System Reset” paragraph).*

15.1. ALARM INTERVENTION

The alarm intervention causes the **cycle interruption** (or the normal operation interruption), the display of the relevant **alarm code** and **message** and an **audible warning**.

15.2. ALARM DURING CYCLE

The alarm procedure is designed in order not to give the user any possibility to confuse an anomalous cycle with an efficiently carried out one, and therefore to **unintentionally use not sterilized materials**; it is structured to guide the user up to the **PRESET** of the sterilizer and the following use.

15.3. SYSTEM RESET

The system can be reset in two alternative ways, depending on the type of alarm occurred (see the List of alarm codes below in this appendix):

1. Pressing the button (A);
2. Following the instructions displayed and then pressing the RESET button.

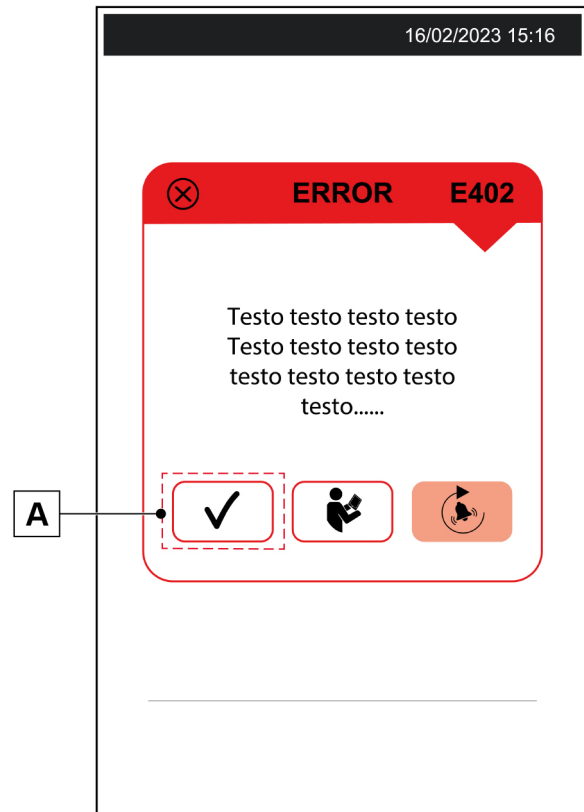

Pressing the RESET button returns to the main menu.

After the RESET and any technical operation necessary to eliminate the fault, the device will be ready to perform a new program.



Never turn off the device before carrying out the reset.

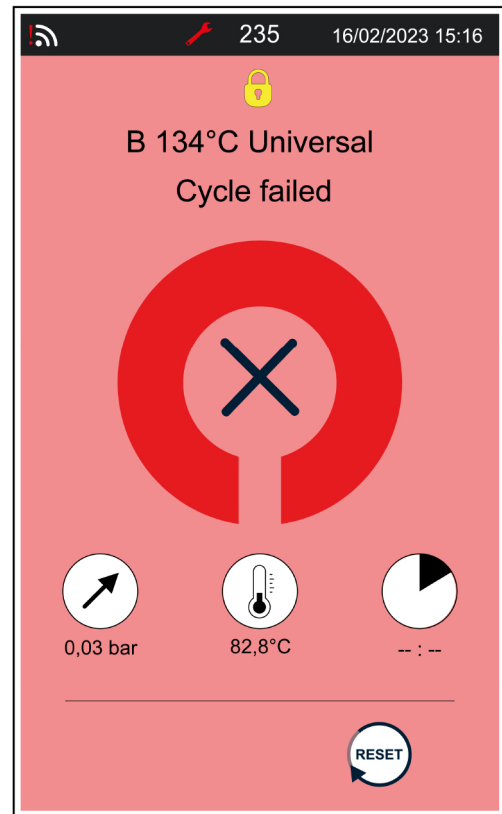

16. ALARM CODES

The list of alarm codes, the relevant messages displayed and RESET modes, are indicated in the following table:

16.1. ERRORS (CATEGORY E)



The alarm codes in the list can refer to functions that are not present on the models concerned in this Manual.

CODE	ALARM DESCRIPTION	MESSAGE ON THE DISPLAY	RESET MODE
E000	Blackout	Power failure	2.3
E001	Overvoltage	Overvoltage Contact tech. service	2.3
E004	Network frequency reading error	Network freq. error Contact tech. service	2.3
E005	Voltage below acceptable limit	Voltage below limit	2.3
E032	Filling tank Inconsistency between full and empty tank floats	Filling tank sensor problem Contact tech. service	2.3
E033	Discharge tank Inconsistency between full and empty tank floats (PLATINUM only)	Discharge tank sensor problem Contact tech. service	2.3
E034	Structural integrity error on RAM data and parameters used in the cycle	System error. Restart the machine. If the problem persists, contact the Technical Service Dept.	2.3
E035	Recirculation filter removed during cycle	Discharge tank filter removed during cycle	2.3
E036	SW watchdog	System error. Restart the machine. If the problem persists, contact the Technical Service Dept.	2.3
E037	Error executing FW	System error. Restart the machine. If the problem persists, contact the Technical Service Dept.	2.3
E040	Data saving error Contact tech. service	Error while saving a Log in the flash memory	2.3
E041	Incorrect sterilization time	Error in the selection of process time 5.5' or 10' option for the concerned cycles only	2.3
E095	Exception in the application's operation	System error. Restart the machine. If the problem persists, contact the Technical Service Dept.	2.3
E096	HW watchdog	System error. Restart the machine. If the problem persists, contact the Technical Service Dept.	2.3
E099	Problem during cycle report generation	Problem during cycle report creation	2.3
E100	Internal management control of the state machine that manages the process	System error Contact tech. service	2.3
E101	PT1 probe open circuit (chamber)	PT1 open circuit (chamber probe) Contact tech. service	2.3
E102	PT2 probe open circuit (steam generator)	PT2 open circuit (generator probe) Contact tech. service	2.3
E103	PT3 probe open circuit (heating band)	PT3 open circuit (heating band probe) Contact tech. service	2.3
E104	NTC probe open circuit (exchanger)	NTC open circuit (exchanger probe) Contact tech. service	2.3
E105	Conductivity probe open circuit	Conductivity sensor open circuit Contact tech. service	2.3
E111	PT1 probe reading error (chamber)	PT1 error (chamber probe) Contact tech. service	2.3
E112	PT2 probe reading error (steam generator)	PT2 error (generator probe) Contact tech. service	2.3
E113	PT3 probe reading error (heating band)	PT3 error (heating band probe) Contact tech. service	2.3
E114	NTC probe reading error (exchanger)	NTC error (exchanger probe) Contact tech. service	2.3

CODE	ALARM DESCRIPTION	MESSAGE ON THE DISPLAY	RESET MODE
E115	Conductivity sensor reading error	Conductivity sensor error Contact tech. service	2.3
E116	Generic HW error	Board fault Contact tech. service	2.3
E117	Door motor overcurrent error	Motor Door overcurrent	2.3
E120	1k3 reference resistor error	Board fault Contact tech. service	2.3
E121	1k5 reference resistor error	Board fault Contact tech. service	2.3
E122	1k8 reference resistor error	Board fault Contact tech. service	2.3
E123	Micro NAND (large) external flash memory error on process board.	Flash memory error Contact tech. service	2.3
E124	Micro NOR (small) external flash memory error on process board.	Flash memory error Contact tech. service	2.3
E128	Communication error with ESP32	Wi-Fi module fault Contact tech. service	2.3
E129	Communication error with NFC board	NFC board fault Contact tech. service	2.3
E140	Error during update file transmission.	Wi-Fi module FW update error	2.3
E143	FW update error	Error during firmware update	2.3
E144	Missing video tutorial! Repeat tutorial update.	No video tutorials found in memory	2.3
E145	Total current measurement fault (too high or too different from estimated value).	Faulty current draw Contact tech. service	2.3
E146	Fault signal from solenoid valve driver	Solenoid valve driver fault Contact tech. service	2.3
E147	Fault signal from door motor driver	Door motor driver fault Contact tech. service	2.3
E148	Copy only one tutorial update .ZIP file to the USB stick	More than one .ZIP file found on USB stick and FW does not know which one to use	2.3
E150	PRESS sensor open circuit (chamber)	Pressure sensor open circuit Contact tech. service	2.3
E160	PRESS sensor short circuit (chamber)	Pressure sensor error Contact tech. service	2.3
E201	Generator resistor open (not heating)	Steam generator heating failed Contact tech. service	2.3
E202	Heating band resistor open (not heating)	Heating band heating failed Contact tech. service	2.3
E250	Error during lowering to 1PV	Error 1° vacuum lowering (1PV) Check filling Check chamber filter	2.3
E251	Error during pressure rise from 1PV to TMJ1	Error 1° pressure rise (1PV-TMJ1) Contact tech. service	2.3
E252	Error during pressure rise from TMJ1 to 1PP	Error 1° pressure rise (TMJ1-1PP) Contact tech. service	2.3
E253	Error during lowering to 2PV	Error 2° vacuum lowering (2PV) Check filling Check chamber filter	2.3
E254	Error during pressure rise from 2PV to TMJ2	Error 2° pressure rise (2PV-TMJ2) Contact tech. service	2.3
E255	Error during pressure rise from TMJ2 to 2PP	Error 2° pressure rise (TMJ2-2PP) Contact tech. service	2.3
E256	Error during lowering to 3PV	Error 3° vacuum lowering (3PV) Check filling Check chamber filter	2.3
E257	Error during pressure rise from 3PV to TMJ3	Error 3° pressure rise (3PV-TMJ3) Contact tech. service	2.3
E258	Error during pressure rise from TMJ3 to 3PP (ET)	Error 3° pressure rise (TMJ3-3PP) Contact tech. service	2.3

CODE	ALARM DESCRIPTION	MESSAGE ON THE DISPLAY	RESET MODE
E260	Error during steam discharge from SE at TMJ3 atmospheric pressure	Pressure discharge error (SE-TMJ3) Contact tech. service	2.3
E261	Chamber pressure levelling error	Pressure levelling error Contact tech. service	2.3
E262	Pressure pulses error in chamber during drying	Drying error (pressure rise) Contact tech. service	2.3
E353	Error during steam discharge from 1PP at TMJ1 atmospheric pressure	Pressure discharge error (1PP-TMJ1) Contact tech. service	2.3
E356	Error during steam discharge from 2PP at TMJ2 atmospheric pressure	Pressure discharge error (2PP-TMJ2) Contact tech. service	2.3
E360	Vacuum phase error up to SPD	Vacuum lowering error (TMJ3-SPD) Contact tech. service	2.3
E362	Vacuum phases error during lowering in drying	Drying error (vacuum lowering) Contact tech. service	2.3
E400	SteamT too high compared to PT1 during process	Wrong P/T ratio Check filling Relaunch the cycle	2.3
E401	PT1 too high compared to steamT during process	Wrong P/T ratio Check filling Relaunch the cycle	2.3
E402	PT1 too high during process	Temperature above maximum limit Contact tech. service	2.3
E403	PT1 too low during process	Temperature below minimum limit Contact tech. service	2.3
E404	Difference between PT1 max and min too high during process	Unstable temperature Contact tech. service	2.3
E405	PRESS too high during process	Pressure above maximum limit Contact tech. service	2.3
E406	PRESS too low during process	Pressure below minimum limit Contact tech. service	2.3
E410	Internal timer error	Board timer fault Contact tech. service	2.3
E411	Error in sterilization time, verified with double variables	Sterilization time error	2.3
E500	17-22-28 Water conductivity above 60 uS/cm and more than 5 cycles performed (manual filling or automatic filling no PURE and water filling from Load tank). Signal at cycle start.	Autoclave blocked Unsuitable water quality Change water	2.3
E501	17-22-28/PLUS/PLATINUM Water conductivity above 60 uS/cm and more than 5 cycles performed (automatic filling with PURE and water filling from Load tank). Signal at cycle start (17-22-28) or Cycle stopped (PLUS/PLATINUM).	Autoclave blocked Unsuitable water quality Empty the tank Replace pure filters	2.3
E503	PLUS/PLATINUM Water conductivity above 60 uS/cm and more than 5 cycles performed (manual filling or automatic filling no PURE or with integrated DEMI filter and water filling from Load tank). Cycle stopped.	Autoclave blocked Unsuitable water quality Replace integrated filter (if present) Change water	2.3
E531	Error from solenoid valve driver on EV1	Solenoid valve 1 fault Contact tech. service	2.3
E532	Error from solenoid valve driver on EV2	Solenoid valve 2 fault Contact tech. service	2.3
E533	Error from solenoid valve driver on EV3	Solenoid valve 3 fault Contact tech. service	2.3
E534	Error from solenoid valve driver on EV4	Solenoid valve 4 fault Contact tech. service	2.3
E535	Error from solenoid valve driver on EV5	Solenoid valve 5 fault Contact tech. service	2.3
E536	Error from solenoid valve driver on EV6	Solenoid valve 6 fault Contact tech. service	2.3

CODE	ALARM DESCRIPTION	MESSAGE ON THE DISPLAY	RESET MODE
E537	Error from solenoid valve driver on EV7	Solenoid valve 7 fault Contact tech. service	2.3
E550	Error during door locking (catch closing)	Door locking error Try again Contact tech. service	2.3
E551	Error during door unlocking (catch opening)	Door unlocking error Contact tech. service	2.3
E552	Status error of the front switch of the door locking system	Door locking system error Contact tech. service	2.3
E553	Status error of the switch of the door locking system catches	Door locking system error Contact tech. service	2.3
E554	Door encoder error Contact tech. service	Door motor encoder not working	2.3
E570	USB removed during use Contents may be corrupted	USB removed too soon while writing	2.3
E900	Error in second phase during Vacuum Test	Vacuum Test failed (second phase) Contact tech. service	2.3
E901	Error in first phase during Vacuum Test	Vacuum Test failed (first phase) Contact tech. service	2.3
E902	Error in achieving the vacuum value required for Vacuum Test	Vacuum test failed Vacuum not reached Contact tech. service	2.3
E990	PRESS too high (not phase dependent)	Pressure above maximum limit Contact tech. service	2.3
E991	PT1 overheating	PT1 overheating Check filling	2.3
E992	PT2 overheating	PT2 overheating Contact tech. service	2.3
E993	PT3 overheating	PT3 overheating Contact tech. service	2.3
E994	Radiator NTC overheating	High discharge fluid temperature Check correct machine ventilation	2.3
E999	Manually interrupting the cycle	Manual interruption of the cycle	2.3

- 1 = OK (warning)
2 = OK + Stopped cycle start
3 = Cycle failed + OK + RESET

16.2. WARNING (CATEGORY W)

CODE	ALARM DESCRIPTION	MESSAGE ON THE DISPLAY	RESET MODE
W001	Confirmation of chamber cooling wait to start Vacuum Test	Chamber temperature too high Test start postponed Do you want to wait?	1
W002	17-22-28 Water conductivity above 15 uS/cm (manual filling or automatic filling no PURE and water filling from Filling tank). Signal at cycle start.	Insufficient water quality	1
W003	17-22-28 Water conductivity above 60 uS/cm and less than 5 cycles performed (manual filling or automatic filling no PURE and water filling from Filling tank). Signal at cycle start.	Unsuitable water quality Change water	1
W004	PLATINUM Water conductivity above 60 uS/cm (with integrated RECIRCULATION filter and water filling from Discharge tank). Signal at cycle end.	Filters exhausted Water recirculation disabled Replace integrated filters	1
W005	Problem accessing USB key	USB stick problem Replace the stick	1
W006	Error opening a file on USB key (reading/writing)	USB stick not accessible Replace the stick	1
W008	17-22-28/PLUS/PLATINUM Water conductivity above 15 uS/cm (automatic filling with PURE and water filling from Filling tank). Signal at cycle start (17-22-28) or cycle end (PLUS/PLATINUM).	Filters nearly exhausted	1
W009	17-22-28/PLUS/PLATINUM Water conductivity above 60 uS/cm and less than 5 cycles performed (automatic filling with PURE and water filling from Filling tank). Signal at cycle start (17-22-28) or cycle end (PLUS/PLATINUM).	Unsuitable water quality Empty the tank Replace pure filters	1
W010	Open door	Open door Close door	1
W011	Check the door Please, open and then close the door	Check the door position if it does not open	1
W012	PLATINUM Number of cycles with RECIRCULATION filter exhausted, or water conductivity level too high (with RECIRCULATION filter fitted). Signal at machine switch-on and when cycle ends.	Filters exhausted Water recirculation disabled Replace integrated filters	1
W014	Request to perform a service maintenance	Authorize remote connection?	1
W015	USB stick full	USB stick full Replace the stick	1
W016	Communication with printer failed	Printer disconnected Check connection	1
W017	Printer: no paper	Printer paper fault	1
W018	Printer: door open	Printer door open	1
W019	Generic error from printer that does not issue a precise message	Printer fault	1
W022	PLUS/PLATINUM Water conductivity above 15 uS/cm (manual filling or automatic filling no PURE or with integrated DEMI filter and water filling from Filling tank). Signal at cycle end.	Insufficient water quality Integrated water filter nearly exhausted (if present)	1
W023	PLUS/PLATINUM Water conductivity above 60 uS/cm and less than 5 cycles performed (manual filling or automatic filling no PURE or with integrated DEMI filter and water filling from Filling tank). Signal at cycle end.	Unsuitable water quality Replace integrated filter (if present) Change water	1
W030	Load tank in reserve	Filling tank minimum level Fill the tank	1
W031	Discharge tank full For PLATINUM disabled if recirculation active	Discharge tank maximum level Empty the tank	1

CODE	ALARM DESCRIPTION	MESSAGE ON THE DISPLAY	RESET MODE
W040	Tank filling with automatic filling failed	No water entry Check automatic filling	1
W041	Load tank maximum level error (automatic filling)	Automatic filling Tank maximum level reached	1
W042	Load tank maximum level error (manual filling)	Manual filling Tank maximum level reached	1
W043	Load tank maximum level error (with active recirculation)	Discharge tank maximum level reached Empty the tank	1
W060	LAN connection error due to Ethernet configuration parameters	Ethernet config. fault Check settings	1
W061	Wi-Fi connection error due to Wi-Fi configuration parameters	Wi-Fi config. fault Check settings	1
W070	Remote printer not shared	Shared printer function deactivated	1
W071	Connection problems with the remote printer. Try again	General connection problems with the printer. Displayed only in case of remote printing and refers to a network connection problem.	1
W102	NFC overwrite request	NFC already associated with a user, overwrite?	1
W104	Error the selected user is not associated with the NFC found	The user selected is NOT associated to this NFC	1
W131	The selected user is not authorised to start or download the cycle	User not authorised	1
W141	The Process FW has detected a mismatch with the Cloud FW. This inconsistency can lead to malfunctions in connectivity to the practice SW or the Cloud.	Incorrect Wi-Fi module FW version Update the FW	1
W201	Periodic maintenance. Default 250 cycles or 120 days.	Clean chamber filter	1
W202	Periodic maintenance. Default 500 cycles or 180 days.	Clean dust filter Clean water tanks Replace bacteriological filter	1
W203	Periodic maintenance. Default 1,000 cycles or 365 days.	Replace door gasket Lubricate the door locking system	1
W204	Periodic maintenance. Default 3,000 cycles or 1,200 days.	Perform periodic maintenance Contact tech. service	1
W205	Periodic maintenance is about to expire W202. To be shown from 100 cycles or 30 days before expiry.	Bacteriological filter to be replaced in xx cycles/ days	1
W206	Periodic maintenance is about to expire W202. To be shown from 50 cycles or 15 days before expiry.	Bacteriological filter to be replaced in xx cycles/ days	1
W207	Periodic maintenance is about to expire W203. To be shown from 100 cycles or 30 days before expiry.	Door gasket to be replaced in xx cycles/days	1
W208	Periodic maintenance is about to expire W203. To be shown from 50 cycles or 15 days before expiry.	Door gasket to be replaced in xx cycles/days	1
W209	Periodic maintenance is about to expire W204. To be shown from 100 cycles or 30 days before expiry.	Maintenance required in xx cycles/days Contact tech. service	1
W215	Bacteriological filter to be replaced in XX days	Periodic maintenance W202 due. Displayed 30 days before expiry	1
W216	Bacteriological filter to be replaced in XX days	Periodic maintenance W202 due. Displayed 15 days before expiry	1
W217	Door gasket to be replaced in XX days	Periodic maintenance W203 due. Displayed 30 days before expiry	1
W218	Door gasket to be replaced in XX days	Periodic maintenance W203 due. Displayed 15 days before expiry	1
W219	Maintenance required in XX days Contact tech. service	Periodic maintenance W204 due. Displayed 30 days before expiry	1
W230	Confirm maintenance has been carried out?	Confirm that maintenance has been carried out	1
W231	Password error	Wrong password or PIN entered	1

1 = OK (warning)

- 2** = OK + Stopped cycle start
- 3** = Cycle failed + OK + RESET

16.3. INFO (CATEGORY I)

CODE	ALARM DESCRIPTION	MESSAGE ON THE DISPLAY	RESET MODE
I001	Reset to factory settings (from Service menu)	Reset initial settings Do you confirm?	1
I002	User deletion confirmation	Delete user Do you confirm?	1
I004	Request for confirmation that the filter has been replaced (at power-on with expired maintenance or error due to high conductivity, or with machine on when a filter is inserted in the discharge tank).	Filter installed/replaced Do you confirm?	1
I005	Confirmation for performing FW update	New FW available Do you want to perform the update?	1
I008	Identifier of a new User you want to create, already in memory.	User already in memory or already used	1
I020	Number of cycles has been exhausted without downloading in New mode	Run backup Download new cycles	1
I021	Flash data overwriting start	Cycle memory full Start of overwriting	1
I030	Pressure levelling in progress Please wait...	Request to unlock the door with pressure too low, wait for pressure levelling	1
I050	Vacuum Test performance reminder	Test reminder Perform Vacuum Test	1
I051	Helix Test performance reminder	Test reminder Perform Helix/B&D Test	1
I052	Vacuum Test + Helix Test performance reminder	Test reminder Perform Vacuum + Helix/B&D Test	1
I070	With preheating active and with the door open, after 10 min and after 20 min the pop-up is shown.	Preheating activated It is advisable to close the door	1
I073	Printer busy. Please wait...	Remote print request failed because the printer is busy with another device.	1
I080	When minimum modular drying is selected, the user is requested to confirm that the correct load has been inserted.	Minimum drying set: make sure that the load has been reduced. Confirm?	1
I100	Prompt to associate an NFC with the selected user	Associate an NFC to the user?	1
I101	Request to move the NFC card closer to the sensor	Move the NFC to be associated closer The NFC data will be erased	1
I103	NFC successfully associated with the selected "XX" user	NFC successfully associated with xxx	1
I126	Esp32 update in progress	Wi-Fi FW update Please wait...	1
I127	FW update Please wait...	FW update in progress. Wait for it to finish	1
I130	Configuration saved Switch the device off and on	Configuration saved, please turn the device off and on again	1
I131	Safety lock Maintenance in remote or via App in progress	Display lock due to an activity in progress from the App or in Remote	1
I998	Cycle Reset request at the end of failed cycle	Do you conf. reset? Caution, unsterilized material	1
I999	Cycle Stop request in progress	Cycle interruption. Do you confirm?	1

- 1 = OK (warning)
- 2 = OK + Stopped cycle start
- 3 = Cycle failed + OK + RESET

16.4. TROUBLESHOOTING

According to the **type of alarm** occurred, please find below the indications to detect the possible causes and restore the proper operation:

16.4.1. ERRORS (CATEGORY E)



The alarm codes in the list can refer to functions that are not present on the models concerned in this Manual.

CODE	POSSIBLE CAUSE	SUGGESTED SOLUTION
E000	Sudden power failure (blackout).	Wait for the power to be restored and RESET following the instructions.
	The main switch has accidentally been turned off and/or the power plug pulled from the socket.	Reconnect the plug and/or turn the device on again and RESET according to the instructions.
	Network fuses blown.	Replace with good fuses of equal nominal value. (See the Summary Table in Appendix Technical Characteristics). Turn the device on again and RESET according to the instructions.
E001	Abnormal voltage peak on the mains.	Reset according to the instructions. If the problem occurs again, have the mains electric system checked by a technician.
E004	Failure to main board.	RESET according to the instructions. Contact Technical Service (see Appendix).
	Disturbance on the electrical mains.	RESET according to the instructions. If the problem occurs again, have the electrical mains checked by a technician. If the electrical mains is equipped with a Continuity system, have the system checked by a technician.
E005	Supply voltage value out of limits – check supply voltage	RESET according to the instructions. Disconnect the power cable and check the mains voltage. The value must be within the rated voltage limits +/- 10%.
E032	Water level in the load tank below minimum.	RESET according to the instructions. Top up with water up to the MAX level (or at least up to over the MIN level).
	MIN water level sensor failure.	Contact Technical Service (see Appendix).
E033	Water level in the drain tank over the MAX level.	RESET according to the instructions and empty the tank. Completely drain the drain tank.
	MAX water level sensor failure.	Contact Technical Service (see Appendix).
E034	Malfunction of the control software.	RESET according to the instructions. Try restarting the program a second time. If the problem persists, contact Technical Service (see Appendix).
E035	Recirculation filter removal.	End the fail cycle. Reinsert the filter and restart the sterilization cycle.
E036	Malfunction of the control software.	RESET according to the instructions. Try restarting the program a second time. If the problem persists, contact Technical Service (see Appendix).
E037	FW malfunction	RESET according to the instructions. Try restarting the program a second time. If the problem persists, contact Technical Service (see Appendix).
E040	Malfunction of the control software.	RESET according to the instructions. Try restarting the program a second time. If the problem persists, contact Technical Service (see Appendix).
E041	Malfunction of the control software.	RESET according to the instructions. Try restarting the program a second time. If the problem persists, contact Technical Service (see Appendix).
E095	Malfunction of the control software.	RESET according to the instructions. Try restarting the program a second time. If the problem persists, contact Technical Service (see Appendix).
E096	HW watchdog	RESET according to the instructions. Try restarting the program a second time. If the problem persists, contact Technical Service (see Appendix).
E099	FW malfunction	Try turning the device off and then on again. Contact Technical Service (see Appendix).
E100	FW malfunction	Try turning the device off and then on again. Contact Technical Service (see Appendix).
E101	Chamber temperature sensor failure (PT1).	Contact Technical Service (see Appendix).
E102	Steam generator temperature sensor failure (PT2).	
E103	Heating element temperature sensor failure (PT3).	

CODE	POSSIBLE CAUSE	SUGGESTED SOLUTION
E104	Discharge fluid temperature sensor failure (NTC).	
E105	PT5 temperature sensor failure (conductivity measurement compensation).	
E111	Chamber temperature sensor reading fault (PT1).	Contact Technical Service (see Appendix).
E112	Steam generator temperature sensor reading fault (PT2).	
E113	Heating element temperature sensor reading fault (PT3).	
E114	Discharge fluid temperature sensor reading fault (NTC)	
E115	PT5 temperature sensor reading fault (conductivity measurement compensation)	
E116	HW fault	Contact Technical Service (see Appendix).
E117	Current drawn by door motor over limit	Grease door pin. Contact Technical Service (see Appendix).
E120	Reference heating element acquisition chain fault.	Contact Technical Service (see Appendix).
E121	Reference heating element acquisition chain fault.	
E122	Reference heating element acquisition chain fault.	
E123	Flash memory damaged.	Contact Technical Service (see Appendix).
	Electronic board damaged.	
E124	Flash memory damaged.	Contact Technical Service (see Appendix).
	Electronic board damaged.	
E128	Connection error with Wi-Fi module	Contact Technical Service (see Appendix).
E129	Error executing FW NFC component failure FW not updated	Try turning the device off and then on again. Update the FW. Contact Technical Service (see Appendix).
E140	Error during update file transmission	Contact Technical Service (see Appendix).
E143	Error during update file transmission	Contact Technical Service (see Appendix).
E144	Error during update file transmission	Contact Technical Service (see Appendix).
E145	Faulty current draw detected	Check mains voltage. Contact Technical Service (see Appendix).
E146	Solenoid valves control driver fault	Contact Technical Service (see Appendix).
E147	Door motor control driver fault	Contact Technical Service (see Appendix).
E148	More than one .ZIP file found on USB stick	Copy only one tutorial update .ZIP file to the USB stick.
E150	Pressure sensor failure (MPX).	Contact Technical Service (see Appendix).
E160	Pressure sensor (MPX) not properly connected to the connector.	Contact Technical Service (see Appendix).
	Pressure sensor short circuit (MPX).	
E201	Steam generator safety thermostat triggered.	Contact Technical Service (see Appendix).
	Steam generator or heating element malfunction.	
E202	Heating band safety thermostat triggered.	Contact Technical Service (see Appendix).
	Heating band malfunction.	
E250	Water or condensate in the sterilization chamber.	RESET according to the instructions. Thoroughly dry the inside of the sterilization chamber and restart the cycle. Do <u>not</u> insert material impregnated with water or in general with liquids into the chamber.
	Drain filter obstructed.	Clean the drain filter (see Appendix Maintenance).
	Air seepage through the gasket.	RESET according to the instructions. Thoroughly clean the gasket with a clean cotton cloth moistened with water. Restart the cycle.
	Vacuum pump failure. Problem in the hydraulic circuit.	Contact Technical Service (see Appendix).

CODE	POSSIBLE CAUSE	SUGGESTED SOLUTION
E251	Water injection pump malfunction.	Contact Technical Service (see Appendix).
	Problem in the hydraulic circuit.	
	Steam generator safety thermostat triggered.	
	Steam generator malfunction.	
E252	Steam seepage through the gasket.	RESET according to the instructions. Thoroughly clean the gasket with a clean cotton cloth moistened with water. Restart the cycle.
	Excessive load.	RESET according to the instructions. Check that the load does not exceed the maximum values allowed (See the Summary Table in Appendix "Technical Characteristics").
	Problem in the hydraulic circuit.	Contact Technical Service (see Appendix).
	Steam generator safety thermostat triggered.	
	Steam generator malfunction.	
E253	Water or condensate in the sterilization chamber.	RESET according to the instructions. Thoroughly dry the inside of the sterilization chamber and restart the program. Do <u>not</u> insert material impregnated with water or in general with liquids into the chamber.
	Air seepage through the gasket.	RESET according to the instructions. Thoroughly clean the gasket with a clean cotton cloth moistened with water. Restart the program.
	Vacuum pump failure.	Contact Technical Service (see Appendix).
	Problem in the hydraulic circuit.	
E254	Water injection pump malfunction.	Contact Technical Service (see Appendix).
	Problem in the hydraulic circuit.	
	Steam generator safety thermostat triggered.	
	Steam generator malfunction.	
E255	Steam seepage through the gasket.	RESET according to the instructions. Thoroughly clean the gasket with a clean cotton cloth moistened with water. Restart the program.
	Excessive load.	RESET according to the instructions. Check that the load does not exceed the maximum values allowed (See the Summary Table in Appendix "Technical Characteristics").
	Problem in the hydraulic circuit.	Contact Technical Service (see Appendix).
	Steam generator safety thermostat triggered.	
	Steam generator malfunction.	
E256	Water or condensate in the sterilization chamber.	RESET according to the instructions. Thoroughly dry the inside of the sterilization chamber and restart the program. Do <u>not</u> insert material impregnated with water or in general with liquids into the chamber.
	Air seepage through the gasket.	RESET according to the instructions. Thoroughly clean the gasket with a clean cotton cloth moistened with water. Restart the program.
	Vacuum pump failure.	Contact Technical Service (see Appendix).
	Problem in the hydraulic circuit.	
E257	Steam seepage through the gasket.	Contact Technical Service (see Appendix).
	Excessive load.	
	Problem in the hydraulic circuit.	
	Steam generator safety thermostat triggered.	
E258	Steam seepage through the gasket.	RESET according to the instructions. Thoroughly clean the gasket with a clean cotton cloth moistened with water. Restart the program.

CODE	POSSIBLE CAUSE	SUGGESTED SOLUTION
	Excessive load.	RESET according to the instructions. Check that the load does not exceed the maximum values allowed (See the <u>Summary Table</u> in Appendix "Technical Characteristics").
	Problem in the hydraulic circuit.	Contact Technical Service (see <u>Appendix</u>).
	Steam generator safety thermostat triggered.	
	Steam generator malfunction.	
E260	Drain filter obstructed.	Clean the drain filter (see <u>Appendix Maintenance</u>).
	Problem in the hydraulic circuit.	Contact Technical Service (see <u>Appendix</u>).
E261	Bacteriological filter obstructed.	Clean the drain filter (see <u>Appendix Maintenance</u>).
	Problem in the hydraulic circuit.	Contact Technical Service (see <u>Appendix</u>).
E262	Bacteriological filter obstructed.	Clean the drain filter (see <u>Appendix Maintenance</u>).
	Problem in the hydraulic circuit.	Contact Technical Service (see <u>Appendix</u>).
E353	Drain filter obstructed.	Clean the drain filter (see <u>Appendix Maintenance</u>).
	Problem in the hydraulic circuit.	Contact Technical Service (see <u>Appendix</u>).
E356	Drain filter obstructed.	Clean the drain filter (see <u>Appendix Maintenance</u>).
	Problem in the hydraulic circuit.	Contact Technical Service (see <u>Appendix</u>).
E360	Drain filter obstructed.	Clean the drain filter (see <u>Appendix Maintenance</u>).
	Problem in the hydraulic circuit.	Contact Technical Service (see <u>Appendix</u>).
E362	Drain filter obstructed.	Clean the drain filter (see <u>Appendix Maintenance</u>).
	Problem in the hydraulic circuit.	Contact Technical Service (see <u>Appendix</u>).
E400	Problem in the hydraulic circuit.	Contact Technical Service (see <u>Appendix</u>).
E401	Problem in the hydraulic circuit.	
E402	Steam generator malfunction.	
	Problem in the hydraulic circuit.	
E403	Steam generator malfunction.	
	Problem in the hydraulic circuit.	
E404	Problem in the hydraulic circuit.	
	Steam generator malfunction.	
E405	Problem in the hydraulic circuit.	
	Steam generator malfunction.	
E406	Problem in the hydraulic circuit.	
	Steam generator malfunction.	
E410	Timer problem.	
E411	Sterilization time error.	
E500	Use of low quality demineralised water – check label data	Empty the load tank, fill with demineralised water that complies with the limit of 15 µS.
	Conductivity sensor problem	Contact Technical Service (see <u>Appendix</u>).
E501	Use of low quality demineralised water – PURE filter exhausted	Deactivate the automatic filling System, empty the load tank and replace the PURE filters.
	Conductivity sensor problem	Contact Technical Service (see <u>Appendix</u>).
E503	Use of low quality demineralised water – integrated filter exhausted	Empty the load tank and replace the integrated filter.
	Use of low quality demineralised water – check label data	Empty the load tank, fill with demineralised water that complies with the limit of 15 µS.
	Conductivity sensor problem	Contact Technical Service (see <u>Appendix</u>).
E531	Solenoid valve 1 broken	Contact Technical Service (see <u>Appendix</u>).
	Electronic board problem.	
E532	Solenoid valve 2 broken	
	Electronic board problem.	
E533	Solenoid valve 3 broken	
	Electronic board problem.	
E534	Solenoid valve 4 broken	

CODE	POSSIBLE CAUSE	SUGGESTED SOLUTION
	Electronic board problem.	
E535	Solenoid valve 5 broken	
	Electronic board problem.	
E536	Solenoid valve 5 broken	
	Electronic board problem.	
E537	Solenoid valve 5 broken	
	Electronic board problem.	
E550	Closed door detection microswitch failure – check the microswitch	Contact Technical Service (see Appendix).
	Locking system safety pressure switch failure – check the pressure switch	
	Door locking servo motor failure – check servo motor operation.	
	Door double catch / pin engagement problem – check proper engagement	
E551	Door microswitch failure – check microswitches.	Contact Technical Service (see Appendix).
	Door locking servo motor failure – check servo motor operation.	
	Door double catch / pin disengagement problem	
E552	Check door microswitch wiring	Contact Technical Service (see Appendix).
	Check door microswitch	
E553	Check catch microswitch wiring	Contact Technical Service (see Appendix).
	Check catch microswitch	
E554	Door motor encoder malfunction.	Contact Technical Service (see Appendix).
E570	USB removed during download/upload.	Format the USB stick and then reinsert it.
E900	Air seepage through the gasket.	RESET according to the instructions. Thoroughly clean the gasket with a clean cotton cloth moistened with water. Restart the program.
	Problem in the hydraulic circuit.	Contact Technical Service (see Appendix).
E901	Excessive humidity in the sterilization chamber.	RESET according to the instructions. Thoroughly dry the inside of the chamber and restart the program.
	Air seepage through the gasket.	RESET according to the instructions. Thoroughly clean the gasket with a clean cotton cloth moistened with water. Restart the program.
	Problem in the hydraulic circuit.	Contact Technical Service (see Appendix).
E902	Excessive humidity in the sterilization chamber.	RESET according to the instructions. Thoroughly dry the inside of the chamber and restart the program.
	Air seepage through the gasket.	RESET according to the instructions. Thoroughly clean the gasket with a clean cotton cloth moistened with water. Restart the program.
	Vacuum pump failure.	Contact Technical Service (see Appendix).
	Problem in the hydraulic circuit.	
E990	General operating problem.	Contact Technical Service (see Appendix).
E991	General operating problem.	
E992	General operating problem.	
E993	General operating problem.	
E994	Problem in the hydraulic circuit.	Contact Technical Service (see Appendix).
	Incorrect machine installation	Check that the machine is correctly installed and that it is properly aerated.
E999	Manual interruption of the sterilization or test cycle.	RESET according to the instructions.

16.4.2. WARNING (CATEGORY W)

CODE	POSSIBLE CAUSE	SUGGESTED SOLUTION
W001	Chamber temperature too high to perform a Vacuum Test	Wait for the temperature to cool down before running the cycle
W002	The filling tank contains water of inadequate quality (>15 µS/cm)	RESET according to the instructions. Empty the filling tank and refill it with distilled water of adequate quality (<15 µS/cm).
W003	The filling tank contains water of inadequate quality (>60 µS/cm)	RESET according to the instructions. Empty the filling tank and refill it with distilled water of adequate quality (<15 µS/cm).
W004	The filling tank contains water of inadequate quality (>60 µS/cm)	RESET according to the instructions. Empty the filling tank and refill it with distilled water of adequate quality (<15 µS/cm). Empty the discharge tank and replace the recirculation filter.
W005	Pendrive is not formatted correctly	Format the pendrive or try a different pendrive
W006	Pendrive is not formatted correctly	
W008	The filling tank contains water of inadequate quality (>15 µS/cm) in the presence of an automatic filling system with Pure	RESET according to the instructions. Disable the automatic filling system and empty the load tank. Replace the Pure filters and reactivate the automatic filling.
W009	The filling tank contains water of inadequate quality (>60 µS/cm) in the presence of an automatic filling system with Pure	RESET according to the instructions. Disable the automatic filling system and empty the load tank. Replace the Pure filters and reactivate the automatic filling.
W010	Door opening in progress	Wait for the door to open
W011	Failure to recognise open door	Open and then close the door
W012	Number of cycles required for the recirculation filter has been exhausted	RESET according to the instructions. Empty the filling tank and refill it with distilled water of adequate quality (<15 µS/cm). Empty the discharge tank and replace the recirculation filter.
W014	Service maintenance required	Authorize remote connection
W015	USB stick full	Format the pendrive or try a different pendrive
W016	Incorrect printer wiring	Check printer connection
	Printer off	Turn on the printer
W017	Printer: no paper	Add paper to the printer
W018	Printer door open	Close printer door
W019	Faulty printer	Check the printer correct operation or change printer
W022	The filling tank contains water of inadequate quality (>15 µS/cm) in the presence of integrated demi filter	RESET according to the instructions. Empty the filling tank, replace the integrated demi filter and refill the tank with distilled water of adequate quality (<15 µS/cm).
W023	The filling tank contains water of inadequate quality (>60 µS/cm) in the presence of integrated demi filter	RESET according to the instructions. Empty the filling tank, replace the integrated demi filter and refill the tank with distilled water of adequate quality (<15 µS/cm).
W030	Filling water level at minimum	Add demi water to the load tank
W031	Discharge water level at maximum	Empty the discharge tank
W040	Automatic filling system solenoid valve failure	Replace the solenoid valve
	Water mains connection closed	Open the water mains connection (tap)
	Pure softening system clogging	Replace Pure filters
W041	Filling tank maximum level reached (automatic filling)	Wait for automatic filling deactivation
W042	Filling tank maximum level reached (manual filling)	Stop filling the load tank
W043	Discharge tank maximum level reached (with active recirculation)	Empty the discharge tank
W060	Error in data entered for Ethernet configuration	Re-enter the correct Ethernet parameters
W061	Error in data entered for Wi-Fi configuration	Re-enter the correct Wi-Fi parameters
W070	Shared printer function deactivated	On the autoclave, to which the printer is connected, set the shared printer function to ON.
W071	Problems with the network connection used by the remote printer	Check that the autoclave, connected to the remote printer, is correctly connected to the network.
W102	NFC overwrite request	Do or do not proceed with NFC overwriting
W104	Error the selected user is not associated with the NFC found	Associate the NFC with the new user or select the correct user

CODE	POSSIBLE CAUSE	SUGGESTED SOLUTION
W131	User not authorised to start or download the cycle	Other user required
W141	Inconsistency between FW and Wi-Fi module	Update the FW
W201	Periodic maintenance required	Clean chamber filter
W202	Periodic maintenance required	Clean dust filter Clean water tanks Replace bacteriological filter
W203	Periodic maintenance required	Replace door gasket Lubricate the door locking system
W204	Periodic maintenance required	Perform periodic maintenance Contact Technical Service (see Appendix).
W205	Maintenance due date W201 approaching	See error W201
W206	Maintenance due date W202 approaching	See error W202
W207	Maintenance due date W203 approaching	See error W203
W208	Maintenance due date W204 approaching	See error W204
W209	Maintenance due date W205 approaching	See error W205
W215	Periodic maintenance W202 due. Displayed 30 days before expiry.	Acknowledge the pop-up by ticking the box.
W216	Periodic maintenance W202 due. Displayed 15 days before expiry.	Acknowledge the pop-up by ticking the box.
W217	Periodic maintenance W203 due. Displayed 30 days before expiry.	Acknowledge the pop-up by ticking the box.
W218	Periodic maintenance W203 due. Displayed 15 days before expiry.	Acknowledge the pop-up by ticking the box.
W219	Periodic maintenance W204 due. Displayed 30 days before expiry.	Acknowledge the pop-up by ticking the box. Contact Technical Service (see Appendix).
W230	Request of carried out maintenance	Confirm that maintenance has been carried out
W231	Wrong password	Enter the correct password

16.4.3. INFO (CATEGORY I)

CODE	POSSIBLE CAUSE	SUGGESTED SOLUTION
I001	Request to confirm reset to factory settings (from service menu only)	Confirm the action or not
I002	Request to confirm user deletion	Confirm the action or not
I004	Request to confirm filter replacement	Confirm whether or not the filter has been replaced
I005	Request to confirm FW update execution	Confirm the FW update or not
I008	User overwrite request	Confirm overwriting or not
I020	Cycle download required	Perform cycle backup
I021	Cycle download required (overwrite)	Perform cycle backup
I030	Request to unlock the door with pressure too low	Wait for pressure to level out
I050	Vacuum Test performance reminder	Perform Vacuum Test
I051	Helix Test performance reminder	Perform Helix Test
I052	Vacuum Test + Helix Test performance reminder	Perform Vacuum Test + Helix Test
I070	Door open during preheating	Close door
I073	Remote printer busy	Wait until the remote printer is free
I100	NFC association request	Confirm whether or not to associate the NFC with the selected user
I101	Request to move NFC closer	Move the NFC card closer to the sensor
I103	NFC association with user performed	Close notification
I126	Esp32 update in progress	Wait for the update to complete
I127	FW update in progress	Wait for it to finish
I130	Configuration saved	Switch the device off and on again
I131	Maintenance activity in remote or via App in progress	Wait for the activity to finish
I998	Cycle failed	Confirm reset and wait for the machine to release pressure
I999	Current cycle stop confirmation request	Confirm whether or not to stop the cycle

17. USER PIN RESET

 If the user enters the pin incorrectly for 3 times, it is necessary to enter the following unlock pin for four consecutive times when you will be prompted to enter pin again:

9999

18. APPENDIX – ADDITIONAL COMPONENTS



Only use spare parts and additional components that meet the manufacturer's specifications.

DEMINERALISER PURE 100

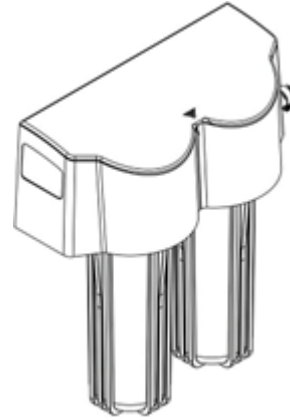

DEMINERALISER PURE 500
TWIN PURE 500

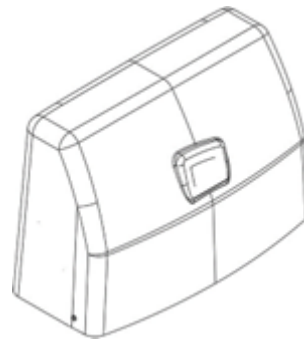

AUTOMATIC FILLING

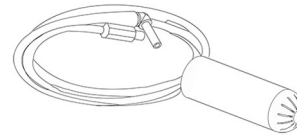

FRONT FILLING

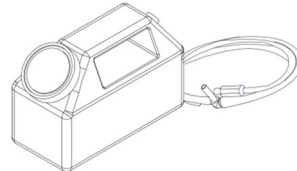

H₂O AUXILIARY SOLENOID VALVE

Additional SV kit including:

- 2-way water solenoid valve, NC - 24 V DC
- Steel support and fastening screws
- Connection cable with plug
- Silicone hose with connector
- Control valve
- 1-way valve

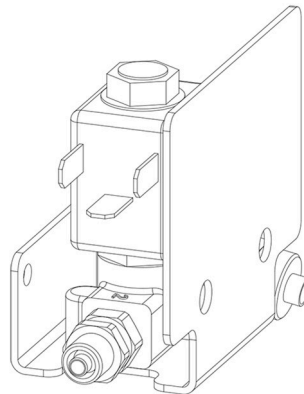

For the management of the additional components for automatic filling, refer to the manual of the additional component.

EXTERNAL PRINTER

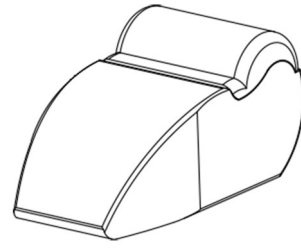

BARCODE READER

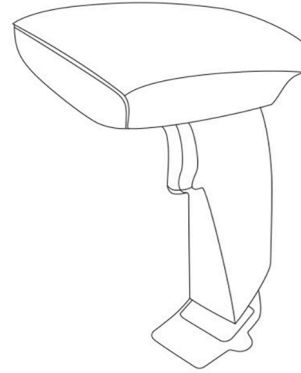

DATA STER SOFTWARE

MY TRACE SOFTWARE

19. PRINTER CONNECTION

Connect the printer to the RS232 serial port located on the rear of the autoclave.

Load the desired type of paper and turn on the printer.
Set the type of label (see the paragraph PRINTERS).



Refer to the printer manual for printer starting and paper loading.

20. APPENDIX - SPARE PARTS AND ADDITIONAL COMPONENTS



Only use spare parts and additional components that meet the manufacturer's specifications.

Description	Code
bacteriological filter	97290160
door gasket (17/22 l)	97400258
door gasket (28 l only)	97467471
chamber filter/water tank	97290210
integrated demineralisation filter	97290277

21. APPENDIX - TECHNICAL SERVICE

FOR ANY REQUEST FOR TECHNICAL INTERVENTION ON THE PRODUCT,
BOTH UNDER WARRANTY AND OUT OF WARRANTY, DIRECTLY CONTACT
THE DEALER OR RESELLER THAT SUPPLIED THE PRODUCT.

We will gladly provide any information you may need on the product as well as give you suggestions and advice on the water steam sterilization procedures.

In this regard, please refer to the following address:

Cefla s.c.

Plant

Via Bicocca, 14/C

40026 - Imola (BO) IT

Tel. +39 0542 653441 Fax. +39 0542 653555

Headquarters

Via Selice Provinciale 23/A – 40026 Imola (BO) IT

22. APPENDIX - WARNINGS AND LOCAL REGULATIONS

Please consult the Web site of the manufacturer to find a list of authorised representatives.



Before carrying out any technical service operations, consult the service manual containing the above instructions.



Making Your Life Better.