

X MIND prime



X-MIND prime 3D User Manual

Contents

1.	<u>INTRODUCTION</u>	<u>1</u>
1.1	Icons appearing in the manual	1
2.	<u>SPECIFICATION OF THE INTENDED USE</u>	<u>2</u>
2.1	Application and medical purpose	2
	2.1.1 Intended patient population	2
	2.1.2 Operator profile	2
	2.1.3 Application environments	3
2.2	Applied parts	4
2.3	Typical doses delivered to the patient during extra-oral exams	4
	2.3.1 Panoramic mode	5
	2.3.2 3D mode	7
3.	<u>SAFETY INFORMATION</u>	<u>8</u>
3.1	Warnings	9
	3.1.1 Precautions while using laser centring devices	10
3.2	Protection against radiation	11
	3.2.1 Pediatric Use: Summary	12
3.3	Information about Electromagnetic Compatibility	14
	3.3.1 Electromagnetic emissions	15
	3.3.2 Electromagnetic immunity	16
3.4	Cybersecurity measures	17
3.5	Environmental risks and disposal	18
3.6	Symbols used	19
4.	<u>CLEANING AND DISINFECTION</u>	<u>21</u>
5.	<u>DESCRIPTION</u>	<u>22</u>
5.1	Identification labels and laser labels	22
	5.1.1 Identification labels and laser labels	23
5.2	Functions, models and versions	24
6.	<u>TECHNICAL CHARACTERISTICS</u>	<u>26</u>
6.1	Dimensions	32
6.2	Tube loading curves, anode heating and cooling curves	35
6.3	Characteristics of the supplied workstation	37
6.4	Software	38
6.5	X-MIND prime 3D – PC communication	38
6.6	Reference standard	39

6.7	CBCT Conditions of Operation	41
6.7.1	Reference Plane	41
6.8	CTDI information	42
6.8.1	Measure conditions	42
6.8.2	Measurement procedure	42
6.8.3	Measured values	43
6.8.4	Measured Dose values for other conditions of operation	44
6.8.5	Dose profile	45
7.	QUALITY ASSURANCE PROGRAM	46
7.1	Quality control tools	47
7.2	Functioning of the indicator lights	48
7.3	Laser alignment check	48
7.4	Panoramic image quality check	49
7.4.1	Log book	52
7.5	3D image quality check	53
7.5.1	"QC Tool" software	54
7.5.2	3D test image acquisition	55
7.5.3	Nyquist frequency	58
7.5.4	Contrast to noise ratio	58
7.5.5	Spatial resolution	59
7.5.6	CT number	59
7.5.7	Length and width measures	59
7.5.8	Slice thickness	60
7.5.9	Homogeneity	60
7.5.10	Dose at the isocenter	61
7.5.11	Acceptance index	61
7.5.12	Log book	62
7.6	Dosimetry test (paragraph for authorised personnel)	63
7.6.1	Log book	65
8.	GENERAL INSTRUCTIONS FOR USE	66
8.1	Switching the device ON and OFF	66
8.1.1	Emergency button	67
8.2	Positioning the chin support	68
8.3	Keyboard - Description and functions	71
8.4	Graphical User Interface - Description and functions	73
8.4.1	Main GUI area functions	75
8.5	Digital sensor	76
9.	MAKING AN EXAM	77

9.1	Anatomic / Manual exposure	83
9.1.1	Anatomic exposure	84
9.1.2	Manual exposure	86
10.	IMAGE PROCESSING WINDOWS	87
11.	2D EXAMS	90
11.1	Standard Panoramic	92
11.2	Left / Right Half Panoramic	92
11.3	Frontal dentition	92
11.4	Low dose Panoramic	92
11.5	Ortho Rad dentition	93
11.6	Single Phase Bitewing (L/R)	93
11.7	Bilateral Bitewing	93
11.8	TMJ O/C	94
11.9	TMJ Single Phase	95
11.10	Sinus	95
12.	3D EXAMS	96
12.1	Full Dentition	96
12.2	Single Jaw and Dental Impression / Dental model scan	96
12.3	Maxillary Teeth	97
12.4	Mandibular Teeth	97
12.5	Extended Volumes / Airways	97
12.6	TMJ	97
12.7	SINUS	97
12.8	Metal Artefact Reduction (MAR) filter	98
12.9	New reconstruction	99
13.	PATIENT POSITIONING	101
13.1	General rules	101
13.2	2D exams	105
13.3	3D exams	105
14.	ERROR MESSAGES	106
15.	MAINTENANCE	109
16.	PANORAMIC IMAGE ASSESSMENT	110
16.1	Proper positioning of the patient	111
16.2	Patient positioning errors	113

<u>16.2.1</u>	<u>Turned head</u>	<u>113</u>
<u>16.2.2</u>	<u>Tilted head</u>	<u>114</u>
<u>16.2.3</u>	<u>Downward angulation of the head</u>	<u>115</u>
<u>16.2.4</u>	<u>Backward angulation of the head</u>	<u>116</u>
<u>16.2.5</u>	<u>Tongue effect</u>	<u>117</u>
<u>16.2.6</u>	<u>Spine effect</u>	<u>118</u>

**Note**

No part of this publication can be reproduced, transmitted, transcribed or translated without the approval of Acteon.
This manual in English is the original Manual version.

1. INTRODUCTION

Note



This manual is updated for the product it is sold with, to guarantee an adequate reference for using the product properly and safely.
The manual may not reflect changes made to the product that do not affect operating procedures or safety.

X-MIND prime 3D, manufactured by de Götzen, is an X-ray device for the radiographic analysis of the maxillo-facial complex.

X-MIND prime 3D performs 2D Panoramic, Half-panoramic, Low dose Panoramic, Frontal dentition, Ortho Rad Panoramic, Bitewing Bilateral, Bitewing Left and Bitewing Right, 2D Sinus and 2D TMJ, 3D Dentition with multiple available FOV centered in different areas of the maxillo-facial complex (Full Dentition, Maxillary Jaw, Mandibular Jaw, Maxillary Teeth, Mandibular Teeth, Extended Volumes), 3D Sinus, 3D TMJ and 3D Airways.

The aim of this Manual is to instruct the user on the safe and effective use of the device. The device must be used complying with the procedures described in this Manual and never be used for purposes other than those indicated herein.

Please read this Manual thoroughly before starting to use the unit; it is advisable to keep the manual close to the device, for reference while operating.

X-MIND prime 3D is an electrical medical device and can only be used under the supervision of a physician or of highly qualified personnel, with necessary knowledge of X-ray protection. The user is liable for legal compliance in relation to the installation and operation of the device.

1.1 Icons appearing in the manual



This icon indicates a "NOTE": please read the items marked by this icon thoroughly.



This icon indicates a "WARNING": the items marked by this icon refer to safety aspects of the patient and/or operator.

2. SPECIFICATION OF THE INTENDED USE

2.1 Application and medical purpose

X-MIND prime 3D is an extra-oral dental panoramic and CBCT (aka CBVT) X-ray unit to take either two dimensional (panoramic, TMJ and sinus exams) or three dimensional radiographic exams of teeth, jaw and oral structures.

Two dimensional images are taken using the narrow beam technique. Three dimensional exams are taken using cone shaped X-ray beam technique; both of them are well known techniques.

The device is operated and used by dentists, radiologists and other legally qualified health care professionals. It can be used with both paediatric and adult patients.

Caution

Federal law restricts this device to sale by or on the order of a dentist, a radiologist or another legally qualified health care professional.

2.1.1 Intended patient population

X-MIND prime 3D system can be used with the following type of patient:

- Age: paediatric (from about 7 years) to geriatric
- Patient status:
 - self-sufficient patient (the patient can autonomously place himself as requested by the physician)
 - non self-sufficient patient (the patient is assisted by medical personnel)
 - in any case the patient must be conscious, not anaesthetized and not incapacitated
- Nationality: multiple.

2.1.2 Operator profile

This system may only be operated by persons who have suitable experience in radiation protection or knowledge of radiation protection and who have been instructed in the operation of the X-ray equipment.

2.1.3 Application environments

X-MIND prime 3D may be used in professional buildings (e.g. hospitals, private clinics) or in residential buildings. For the purpose of EMC environment classification both installations are classified as "Professional healthcare facility environment".



Note

In the radiographic room, direct audio and visual communication between operator and patient shall be always possible. Otherwise, provide proper support (i.e. lead glass or similar, interphone, etc.).

2.2 Applied parts

During normal use, X-MIND prime 3D is in contact with the patient via the handle, the chin rest and bite, the temple clamp and strip, classified as Type B applied parts.

2.3 Typical doses delivered to the patient during extra-oral exams

The dose per area of products delivered by X-MIND prime 3D to the patient during extra-oral exams is indicated in the graphical user interface.



Note

The dosimetric indications result from the average of dose measures on a lot of X-rays source assemblies.

The dose is taken at a certain distance from the focal spot of the X-ray source and then reported to the imaging plane.

To get the DAP value, the dose on the imaging plane is multiplied by the X-ray field area measured on the imaging sensor that is 52 cm far away from focal spot.

The typical size of the X-ray beam on the imaging sensor depends on the selected exam:

- for 2D exams: 140 mm x 4.5 mm
- for 3D Dentition, 3D TMJ, 3D Sinus and Extended Volumes: 144 mm x 118.6 mm
- for 3D Dentition, 3D TMJ and 3D Sinus (FOV 80 x 80 mm): 122.9 mm x 109.9 mm (*)
- for Mandibular and Maxillary dentition: 77 mm x 118.6 mm
- for Mandibular and Maxillary dentition (FOV 80 x 50 mm): 77 mm x 109.9 mm (*)
- for 5x5 volumes: 73 mm x 69 mm

(*) values valid in case a 80 x 80 collimator (kit code 6604061200) is present

The distance between the focal spot and the patient skin is variable during the X-ray and on average we can assume the mean distance between the focal spot and the patient skin as 264 mm.

The overall uncertainty of the indicated value of the air Kerma and dose per area product is 50%.



Note

As stated in IEC 60601-2-63, no deterministic effects are known with extra-oral dental X-ray equipment.

2.3.1 Panoramic mode

The air kerma value at the entrance of the X-ray image receptor for the PANORAMIC exam is reported in the table below as functions of kV and mA.

kV	60	62	64	66	68	70	72	74	76	78	80	82	84	86
mA	Air Kerma [mGy]													
2	3.57	3.85	4.14	4.43	4.72	5.00	5.29	5.58	5.86	6.15	6.44	6.61	6.75	6.88
2.2	3.93	4.24	4.56	4.87	5.19	5.50	5.82	6.13	6.45	6.76	7.08	7.27	7.43	7.57
2.5	4.46	4.82	5.18	5.54	5.89	6.25	6.61	6.97	7.33	7.69	8.04	8.26	8.44	8.60
2.8	5.00	5.40	5.80	6.20	6.60	7.00	7.40	7.81	8.21	8.61	9.01	9.25	9.45	9.63
3.2	5.71	6.17	6.63	7.09	7.54	8.00	8.46	8.92	9.38	9.84	10.30	10.57	10.80	11.00
3.6	6.42	6.94	7.45	7.97	8.49	9.00	9.52	10.04	10.55	11.07	11.58	11.89	12.15	12.38
4	7.14	7.71	8.28	8.86	9.43	10.00	10.58	11.15	11.72	12.30	12.87	13.21	13.50	13.76
4.5	8.03	8.67	9.32	9.96	10.61	11.25	11.90	12.54	13.19	13.83	14.48	14.86	15.19	15.48
5	8.92	9.64	10.35	11.07	11.79	12.50	13.22	13.94	14.65	15.37	16.09	16.52	16.88	17.20
5.6	9.99	10.79	11.60	12.40	13.20	14.00	14.81	15.61	16.41	17.22	18.02	18.50	18.90	19.26
6.3	11.24	12.14	13.05	13.95	14.85	15.76	16.66	17.56	18.46	19.37	20.27	20.81	21.27	21.67
7.1	12.67	13.69	14.70	15.72	16.74	17.76	18.77	19.79	20.81	21.83	22.85	23.45	23.97	24.42
8	14.27	15.42	16.57	17.71	18.86	20.01	21.15	22.30	23.45	24.59	25.74	26.43	27.01	27.51
9	16.06	17.35	18.64	19.93	21.22	22.51	23.80	25.09	26.38	27.67	28.96	29.73	30.38	30.95
10	17.84	19.27	20.71	22.14	23.58	25.01	26.44	27.88	29.31	30.74	32.18	33.03	33.76	34.39
11	19.63	21.20	22.78	24.36	25.93	27.51	29.09	30.66	32.24	33.82	35.39	36.34	37.13	37.83
12.5	22.30	24.09	25.89	27.68	29.47	31.26	33.05	34.84	36.64	38.43	40.22	41.29	42.20	42.99



The air Kerma for the other PANORAMIC exams available on the equipment can be calculated using the ratios vs PANORAMIC EXAM in the table below:

Exam	Ratio
Half panoramic	0.55
Low Dose	0.85
Ortho Rad panoramic	0.90
Frontal dentition	0.33
Bitewing L or R	0.24
Bitewing L and R	0.47
TMJ	0.71
Sinus	0.65

2.3.2 3D mode

The air Kerma value at the entrance of the X-ray image receptor for the 3D exams is reported in the table below as functions of kV and mA.

kV	60	62	64	66	68	70	72	74	76	78	80	82	84	86
mA	Air Kerma [mGy]													
2	1.37	1.48	1.59	1.70	1.81	1.92	2.03	2.14	2.25	2.36	2.47	2.58	2.70	2.81
2.2	1.51	1.63	1.75	1.87	1.99	2.11	2.24	2.36	2.48	2.60	2.72	2.84	2.96	3.09
2.5	1.71	1.85	1.99	2.13	2.26	2.40	2.54	2.68	2.82	2.95	3.09	3.23	3.37	3.51
2.8	1.92	2.07	2.23	2.38	2.54	2.69	2.84	3.00	3.15	3.31	3.46	3.62	3.77	3.93
3.2	2.19	2.37	2.54	2.72	2.90	3.07	3.25	3.43	3.61	3.78	3.96	4.14	4.31	4.49
3.6	2.46	2.66	2.86	3.06	3.26	3.46	3.66	3.86	4.06	4.25	4.45	4.65	4.85	5.05
4	2.74	2.96	3.18	3.40	3.62	3.84	4.06	4.29	4.51	4.73	4.95	5.17	5.39	5.61
4.5	3.08	3.33	3.58	3.83	4.07	4.32	4.57	4.82	5.07	5.32	5.57	5.82	6.06	6.31
5	3.42	3.70	3.98	4.25	4.53	4.80	5.08	5.36	5.63	5.91	6.19	6.46	6.74	7.01
5.6	3.83	4.14	4.45	4.76	5.07	5.38	5.69	6.00	6.31	6.62	6.93	7.24	7.55	7.86
6.3	4.31	4.66	5.01	5.36	5.70	6.05	6.40	6.75	7.10	7.45	7.79	8.14	8.49	8.84
7.1	4.86	5.25	5.64	6.04	6.43	6.82	7.21	7.61	8.00	8.39	8.78	9.18	9.57	9.96
8	5.48	5.92	6.36	6.80	7.24	7.69	8.13	8.57	9.01	9.45	9.90	10.34	10.78	11.22
9	6.16	6.66	7.16	7.65	8.15	8.65	9.14	9.64	10.14	10.64	11.13	11.63	12.13	12.63
10	6.84	7.40	7.95	8.50	9.06	9.61	10.16	10.71	11.27	11.82	12.37	12.92	13.48	14.03
11	7.53	8.14	8.75	9.35	9.96	10.57	11.18	11.78	12.39	13.00	13.61	14.22	14.82	15.43
12.5	8.56	9.25	9.94	10.63	11.32	12.01	12.70	13.39	14.08	14.77	15.46	16.15	16.85	17.54

The air Kerma for TMJs 3D exams can be calculated using the ratio vs 3D mode in the table below:

Exam	Ratio
TMJ 3D	0.9

3. SAFETY INFORMATION

**Warning**

Please read this chapter thoroughly.

Equipment has been designed and manufactured in compliance with safety requirements; furthermore it supplies all information necessary for correct use, and warnings related to dangers associated with X-ray generating units.

Acteon cannot be held liable for:

- Use of X-MIND prime 3D other than its intended use
- Damage to the unit, the operator or the patient, caused both by installation and maintenance procedures other than those described in this Manual and in the Service Manual supplied with the unit, and by erroneous operations
- Mechanical and/or electrical modifications performed during and after the installation, other than those described in the Service Manual.

Installation and any technical operations must only be performed by qualified technicians authorised by Acteon.

Only authorised personnel may remove the covers and/or have access to live components.

**Warning**

In compliance with the IEC 60601-1 standard, the modification of the equipment or its parts is strictly prohibited.

3.1 Warnings

The device must be used in compliance with the procedures described and never be used for purposes other than those indicated herein.

Before performing any maintenance operation, disconnect the unit from the power supply.

X-MIND prime 3D is an electric medical device and so can only be used under the supervision of suitably qualified medical personnel, with necessary knowledge of X-ray protection.

The user is responsible for compliance with legal requirements as regards ownership, installation and use of the equipment.

The user is responsible for a safe set-up and maintenance of the host PC; as a general guidance, cybersecurity suggestions are given in paragraph 3.4 of this Manual.

The user is responsible for the execution of the routine quality control procedure described in chapter 7 of this Manual.

This device has not been designed for use in environments where vapours, anaesthetic mixtures flammable with air, or oxygen and nitrous oxide, may be present.

Do not let water, or other liquids, penetrate the device, as this could cause short circuits and corrosion.

Before cleaning the device, make sure the main power supply has been disconnected from the equipment. When pushing the ON/OFF button of the equipment, it must not come on.

Wherever necessary, use appropriate accessories, such as leaded aprons, to protect the patient from radiation.

While performing the X-ray, no-one, apart from the operator and the patient, must remain in the room.

X-MIND prime 3D has been built for continuous operation with an intermittent load; so the described use cycles must be observed, to enable the device to cool down.

X-MIND prime 3D must be switched off while using electrosurgical devices or similar apparatus.



Warning

For safety reasons, the patient support arm must not be abnormally overloaded, for example by leaning on it. The traction on the handle must be less than 16 kg.



Warning

To avoid the risk of electric shock, the equipment must only be connected to a mains supply with earthing.

Clean and disinfect, when necessary, all parts that may come into contact with the patient.

The centring bite or the bite protective sleeve must be replaced after each exam.

To avoid permanent damage to the unit, never try to rotate the moving arm manually when the unit is switched on.

In the case of Error 362, movement is possible to let the patient exit.



Note

When the unit is switched on, do not move the rotating arm.

3.1.1 Precautions while using laser centring devices

For patient positioning, X-MIND prime 3D uses two laser diodes with optical power on the working surface < 1 mW.

The directive CEI-EN 60825-1 defines the laser as "any device that produces or amplifies electromagnetic radiation in a coherent manner which includes a wave lengths from 180 nm to 1 mm by means of a stimulated emission". In reference to this directive, the lasers present on the X-MIND prime 3D are parts of class 2.

A laser in class 2 can be potentially dangerous if the ray is reflected into not protected eyes by a mirror, watch, a ring etc.

The warning label below is affixed to X-MIND prime 3D to indicate a laser in class 2 is mounted internally and caution is advised:

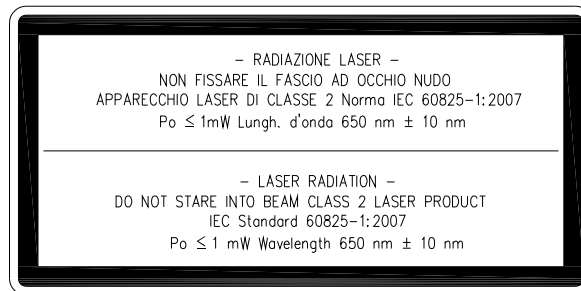

Warning

- Always keep the room well lit.
- Do not look into the output windows of laser centring units.
- Do not stare at the reflections of laser pointers.
- Instruct the patient to keep his/her eyes closed as long as the laser pointers are active.
- Before starting an exam, the patient must remove earrings, glasses, necklaces and any other item that could reflect the laser beam or be impressed on the radiographic image.
- Do not clean the openings of laser centring devices with tools that could modify the optics. Any cleaning must only be performed by authorized technicians.
- Operations other than those indicated could cause the emission of dangerous non-ionizing radiation.

3.2 Protection against radiation

Although the dose supplied by dental X-ray units is quite low and distributed on a fairly small surface, the operator must adopt precautions and/or suitable protection for the patient and himself, during radiography.



Warning

Protection against radiation is regulated according to law.
The equipment may only be used by specialised personnel.

It is advisable to control the X-ray emission from a protected area, by remote control. If it is necessary to operate near the patient, stay as far as the remote control cable allows, or at least 2 m both from the X-ray source and from the patient, as shown in the following figure.

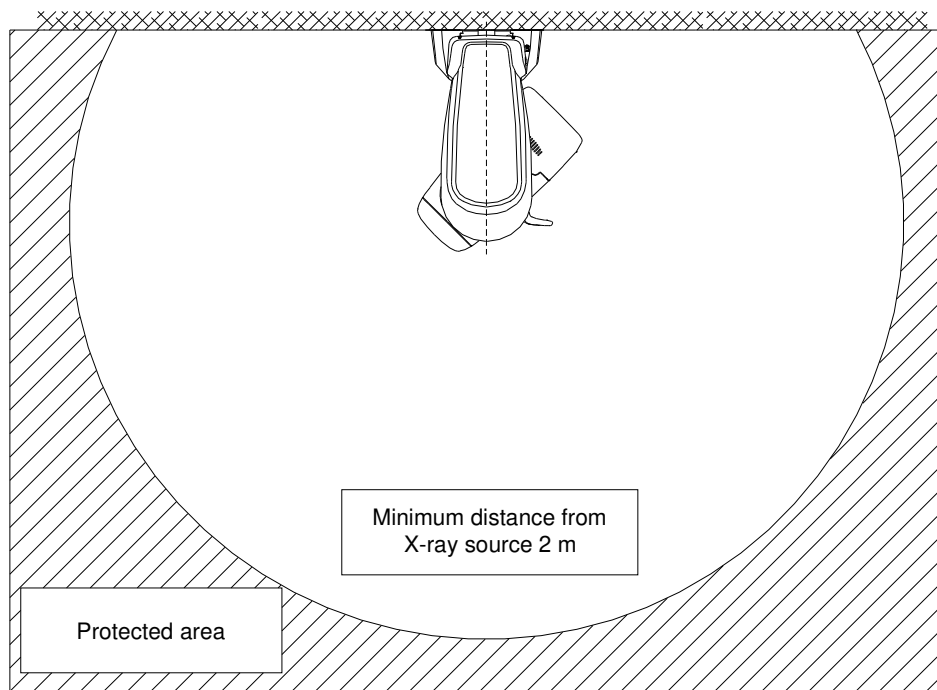

Figure 1



3.2.1 Pediatric Use: Summary

3.2.1.1 Introduction

Special care should be exercised when imaging patients outside the typical adult size range, especially smaller pediatric patients whose size does not overlap the adult size range (e.g., patients less than 50kg (110lb) in weight and 150cm (59") in height, measurements, which approximately correspond to that of an average 12 years old or a 5th percentile U.S. adult female).

3.2.1.2 References for pediatric dose optimization

The following resources provide information about pediatric imaging radiation safety and/or radiation safety for extra-oral dental panoramic and CBCT (aka CBVT) X-ray devices:

1. [HTTPS://WWW.FDA.GOV/RADIATION-EMITTINGPRODUCTS/RADIATIONEMITTINGPRODUCTSANDPROCEDURES/MEDICALIMAGING/UCM298899.HTM](https://www.fda.gov/radiation-emitting-products/radiation-emitting-products-and-procedures/medical-imaging/ucm298899.htm)
2. www.imagegently.org
3. [HTTPS://WWW.FDA.GOV/RADIATION-EMITTINGPRODUCTS/RADIATIONEMITTINGPRODUCTSANDPROCEDURES/MEDICALIMAGING/MEDICALX-RAYS/UCM315011.HTM](https://www.fda.gov/radiation-emitting-products/radiation-emitting-products-and-procedures/medical-imaging/medical-x-rays/ucm315011.htm)
4. <https://www.iaea.org/resources/rpop/resources/training-material#1>
5. [HTTPS://WWW.IAEA.ORG/RESOURCES/RPOP/RESOURCES/TRAINING-MATERIAL#3](https://www.iaea.org/resources/rpop/resources/training-material#3)

3.2.1.3 Device specific features and instructions

X-MIND prime 3D provides as standard with all units, the following specific design features and instructions that enable safer use of our device with pediatric patients:

Design features important to pediatric imaging	Paragraph
Adult/Child exam modality: child selection adapts exposure current (mA) and High voltage (kV) reducing the overall dose supplied to the patient. Exposure parameters of 3D exams for a medium-sized child patient give a dose reduction (compared to the adult patient) as recommended by IAEA (see paragraph above, link #4)	8.4 and 9.1.1
For the panoramic exams (panoramic, half-panoramic and low dose panoramic programs) Child selection also corresponds to a reduced trajectory exam time giving a further 10% of dose reduction.	9.1.1
A function to run the exam in test mode without X-ray to check the behaviour of the patient during the exam and reduce the possibility of exam interruption and retake	9 and 13.1
The recommendation – especially with pediatric patients - to use a smaller FOV when taking a 3D exam.	12

3.3 Information about Electromagnetic Compatibility

Medical electrical equipment needs special precautions regarding EMC and needs to be installed and put into service according to the EMC information provided in the accompanying documents.

Portable and mobile RF communications equipment can affect medical electrical equipment.

The equipment can be installed both in professional buildings (e.g. hospitals or clinics) and in residential buildings. Residential buildings, according to IEC 60601-1-2 4th edition, are intended to be connected to dedicated power supply system (normally fed by separation transformers).

For the purpose of EMC environment classification according to IEC 60601-1-2 4th edition, both installations are classified as "Professional healthcare facility environment".

The EMISSIONS characteristics of this equipment make it suitable for use in industrial areas and hospitals (CISPR 11 class A). If it is used in a residential environment (for which CISPR 11 class B is normally required) this equipment, even if it is usually permanently installed in X-Ray shield locations, might not offer adequate protection to radio-frequency communication services. If abnormal performance is observed, such as degradation of essential performance in the form of lack of accuracy of exposure parameters and lack of reproducibility of exposure parameter, additional measures may be necessary, such as re-orienting or relocating the device.



Warning

The use of cables other than:

- Ethernet cable CAT.5E L=5 m - code 5007090100
- Ethernet cable CAT.5E L=10 m - code 5007090300

with the exception those sold by the manufacturer of the equipment or system as replacement parts for internal components, may result in increased emission or decreased immunity of the equipment or system.



Warning

X-MIND prime 3D should not be used adjacent to or stacked with other equipment; if adjacent use is necessary, X-MIND prime 3D has to be observed to verify if it operates in a normal way.

Interference may occur in the vicinity of equipment marked with the symbol



Warning

Portable and mobile RF communications equipment should be used no closer to any part of X-MIND prime 3D, including cables. Minimum distance 30 cm.

3.3.1 Electromagnetic emissions

In accordance with the IEC 60601-1-2 Ed4 standard, X-MIND prime 3D is suitable for use in the electromagnetic environment specified below.

The customer or user of the system must ensure that it is used in the said environment.

Emissions test	Compliance	Electromagnetic environment
RF emissions CISPR 11	Group I	X-MIND prime 3D uses RF energy only for its internal function. Therefore, its R.F. emissions are very low and are not likely to cause any interference in nearby electronic equipment.
	Class A	X-MIND prime 3D is suitable for use in all establishments other than domestic and those directly connected to the public low voltage power supply network that supplies buildings used for domestic purposes.
Harmonics emissions IEC 61000-3-2	Class A	
Voltage fluctuations/ flicker emissions IEC 61000-3-3	Complies	



3.3.2 Electromagnetic immunity

In accordance with the IEC 60601-1-2 Ed4 standard, X-MIND prime 3D is suitable for use in the electromagnetic environment specified below. The customer or user of the system must ensure that it is used in the said environment.

Immunity test	IEC 60601-1-2 test level	Compliance level	Electromagnetic environment
Electrostatic discharge (ESD) IEC 61000-4-2	8 kV contact 2/4/8/15 kV air	IEC 60601-1-2 Test level	Floors should be wood, concrete or ceramic tile. If floors are covered with synthetic material, the relative humidity should be at least 30%
Radiated electromagnetic field IEC 61000-4-3	3 V/m 80 MHz to 2.7 GHz	IEC 60601-1-2 Test level	Portable and mobile RF communications equipment should be used no closer to any part of X-MIND prime 3D including cables. Minimum distance 30 cm
Electrical fast transient/burst IEC 61000-4-4	2 kV for power supply lines 1 kV for input/output lines > 3 m	IEC 60601-1-2 Test level	Mains power quality should be that of a typical commercial or hospital environment
Surge IEC 61000-4-5	0.5/1 kV differential mode 0.5/1/2 kV common mode	IEC 60601-1-2 Test level	Mains power quality should be that of a typical commercial or hospital environment
Conducted disturbances induced by RF fields IEC 61000-4-6	3 V 150 kHz to 80 MHz 6 V ISM frequencies	IEC 60601-1-2 Test level	Portable and mobile RF communications equipment should be used no closer to any part of X-MIND prime 3D, including cables. Minimum distance 30 cm
Voltage dips, short interruptions and voltage variations on power supply input lines IEC 61000-4-11	10 ms – 0 % a 0°, 45°, 90°, 135°, 180°, 225°, 270°, 315° 20 ms – 0% a 0° 500 ms – 70% a 0° 5 s – 0%	IEC 60601-1-2 Test level	Mains power quality should be that of a typical commercial or hospital environment. If the user of the EUT requires continued operation during power mains interruptions, it is recommended that the EUT be powered from an uninterruptible power supply or a battery
Power frequency (50/60 Hz) magnetic field IEC 61000-4-8	30 A/m	IEC 60601-1-2 Test level	Power frequency magnetic fields should be at levels characteristics of a typical location in a typical commercial or hospital environment

3.4 Cybersecurity measures

Like all computer-based systems, X-MIND prime 3D might be exposed to Cybersecurity threats.

X-MIND prime 3D is equipped with hardware provisions that make sure that no unwanted X-ray exposure, laser radiation or motorized movements can be activated even in case of cyber-attack or software failure.

Nevertheless, in order to minimize the possibility of cyber-attacks, it is the user responsibility to make sure that the following protection measures are followed.

- The initial software installation and system set-up shall be done by authorized and trained personnel only and using the software provided with the machine
- Any software or firmware upgrade of the equipment shall be done by authorized and trained personnel only
- After any software or firmware upgrade, or any other maintenance operation, image quality checks shall be performed to ensure the system is working as expected. Instructions are given in chapter 7
- Password-protect each user account on the Windows login. Passwords shall be strong enough (at least made of 8 alphanumeric characters), shall be safely managed by every user (for example they have not been written down), and should be periodically changed (if the system is supplied with a PC, the Windows user is password-protected, but it is user responsibility to change the default password and set new ones for all the different users that will have access to the system)
- Activate a screensaver that requires a password to be unblocked after a timeout of 5-10 minute, giving this way an automatic timed method to terminate sessions, preventing an unauthorized access to the computer when it is not used (if the system is supplied with a PC, the screen saver is activated by default)
- Install an antivirus software and keep virus definitions up to date
- Activate the windows firewall on the host PC (if the system is supplied with a PC, the Windows firewall is activated by default)
- It is recommended to activate a hardware firewall on the WAN router/modem used for internet connection, if present
- Make sure that all other PCs in the network are protected by an anti-virus
- Make a virus scan of USB sticks or CD/DVD media before using them to check that they are free of viruses, malware or any dangerous software
- Avoid installation of an unknown or untrusted software since it may undermine the performance and safety of the computer and the equipment
- Keep the Windows operating system up to date by installing all security patches
- Make regular copies (backup) of all your valuable data and store them in a safe place, separately from the host PC

3.5 Environmental risks and disposal

Some parts of the device contain materials and liquids that, at the end of the unit's lifecycle, must be disposed of at appropriate disposal centres.

In particular, the device contains the following materials and/or components:

- Tube-head: dielectric oil, copper, iron, aluminium, glass, tungsten, lead.
- Collimator: lead
- Other parts of the device: non-biodegradable plastic materials, metal materials, printed circuits, iron-plastic materials, lead.



Note

Information for users of the European Community according to 2011/65/EU Directive on the restriction of the use of certain hazardous substances in electrical and electronic equipment.



The symbol of the crossed waste container on the equipment or packaging shows that the product, at the end of its lifecycle, must be collected separately from other types of waste.













The separate collection of this equipment at the end of its lifecycle is organised and managed by the manufacturer. Users who need to dispose of this equipment should therefore contact the manufacturer and follow the procedure adopted by the manufacturer for the separate collection of the equipment at the end of its lifecycle.







Proper separate collection for subsequent recycling, treatment and compatible environmental disposal of equipment helps avoid possible negative effects on the environment and on health and encourages the reuse or recycling of materials the equipment is made from.

Illegal disposal of the product by the owner of the equipment will result in administrative sanctions, as provided for by applicable regulations.

3.6 Symbols used

In this manual and on X-MIND prime 3D itself, apart from the symbols indicated on the keyboard, the following icons are also used:

Symbols	Description
	Device with type B applied parts
	Some parts of the device contain materials and liquids that, at the end of the unit's lifecycle, must be disposed of at appropriate disposal centres
~	A.C. voltage
N	Connection point to the neutral conductor
L	Connection point to the line conductor
	Protection grounding
	Functional grounding
	OFF; device not connected to the mains
	ON; device connected to the mains
	Laser
	Dangerous voltage
REF	Product identification code
SN	Serial number
	Manufacturing date (year and month)
	Name and address of the manufacturer
	Filtration
	Tube-head
	X-Ray tube

Symbols	Description
	Focal spot according to IEC 60336
	Follow instructions for use
	Conformity to the Directive 93/42/EEC and its revised version and all other applicable Directives
	Exposure enabled status (the corresponding green LED is on)
	X-Ray emission (the corresponding yellow LED is on)
	Electronic instructions for use symbol for medical devices, according to EN ISO 15223-1: 2016

4. CLEANING AND DISINFECTION

In order to guarantee a good level of hygiene and cleaning, it is necessary to carry out the following procedures.



Warning

Disconnect the unit from the mains before performing any cleaning.

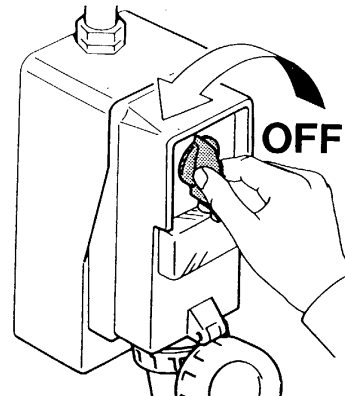

Do not let water or other liquids penetrate the unit, as these could cause corrosion or short circuits.

Use only a wet cloth and a mild detergent to clean the painted surfaces, accessories and connection cables and then wipe with a dry cloth. Do not use corrosive or abrasive detergents (alcohol, benzene, trichloroethylene, products containing quaternary ammonium).

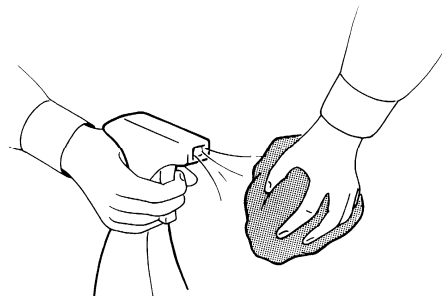

The centring bite or the bite protective sleeve must be replaced after each exam. Thoroughly clean the chin support, resting handles and temple clamps group whenever they are used.

The chin support, resting handles and temple clamps group should be disinfected (when considered necessary) with a solution of 2% glutaraldehyde.



Note

To ensure a greater level of hygiene the handles of the equipment are covered with a special antibacterial paint which, thanks to the emission of silver ions, prevents the development of micro-organisms.

5. DESCRIPTION

5.1 Identification labels and laser labels

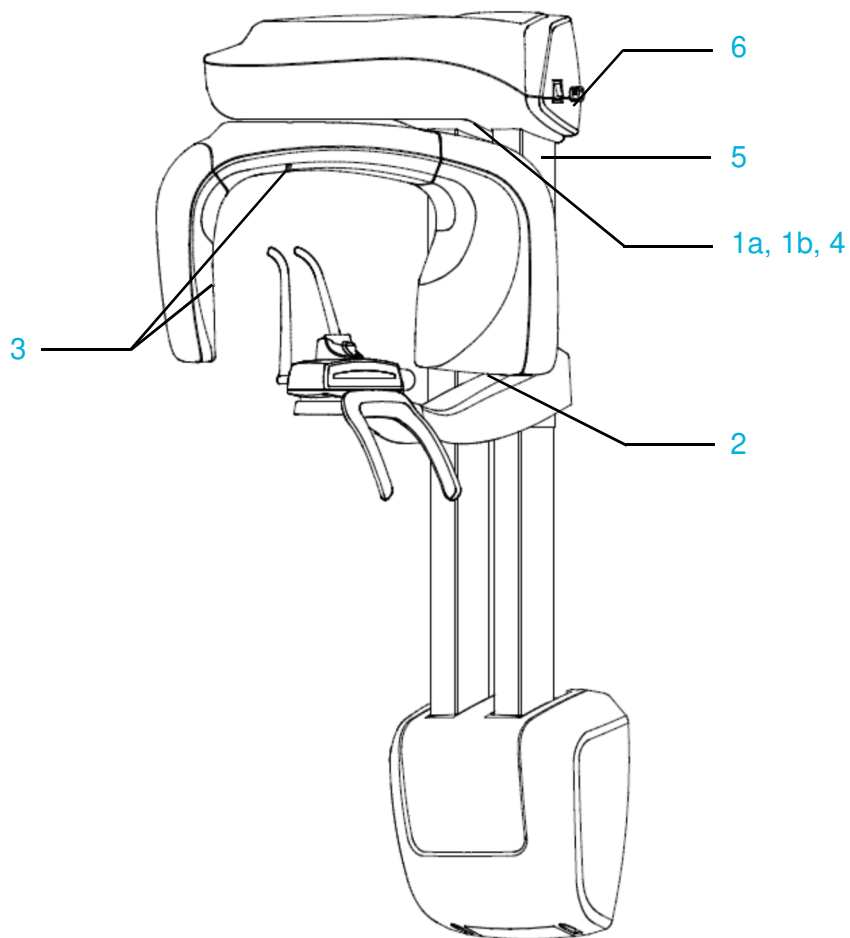
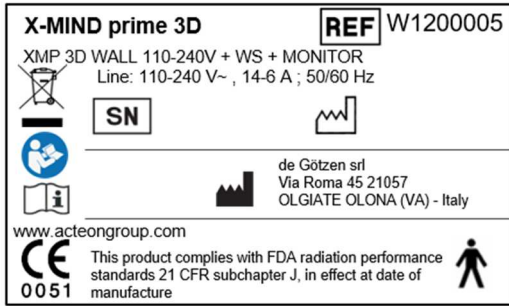

Figure 2: Identification labels

5.1.1 Identification labels and laser labels

1a
X-MIND prime 3D
identification label



1b
UDI label

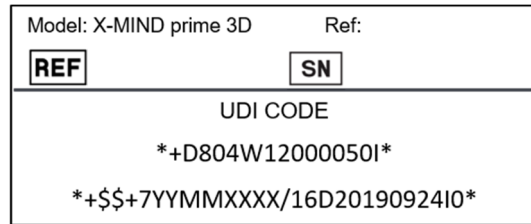

2
Tube-head
identification label

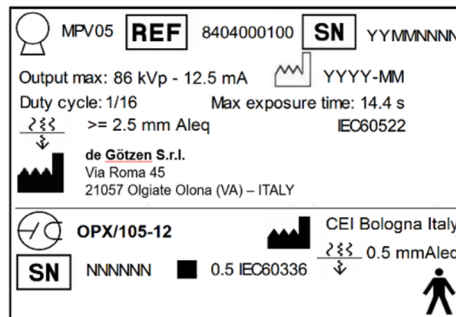

3
(No. 2) Laser symbol label



4
Laser WARNING label



5
WARNING label

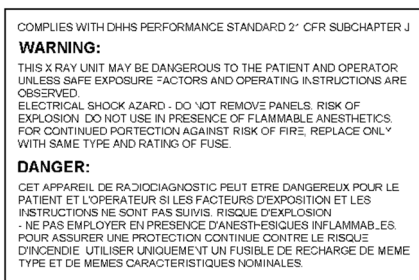

6
Emergency button label



5.2 Functions, models and versions

X-MIND prime 3D, manufactured by de Götzen, is a complete panoramic X-ray system that can perform the following exams:

- Panoramic adult or child exams, with 3 sizes and 3 types of biting for a total of 18 combinations with automatic selection; with manual selection, it is possible to select a high voltage between 60kV and 86kV, in 2kV steps and anodic current from 2 mA to 12.5 mA in the R20 scale steps.
- Sinus mode makes it possible to take exams of the paranasal sinuses with front projection (postero/anterior).
- TMJ closed/open mouth in lateral projection.
- Right or Left Half Panoramic, to be used when the patient is known to have a problem only on one side of the arch, in order to reduce radiation.
- Low dose Panoramic, which reduces the dose radiated by excluding the TMJ's ascending rami from the radiograph.
- Frontal dentition, for a radiograph of the front part (roughly from canine to canine).
- Ortho Rad Panoramic with improved orthogonality, which reduces teeth overlap, thereby improving the diagnosis of interproximal decay.
- Bitewing Left or Right, for lateral dentition (generally from eighth to fourth) with a trajectory that reduces teeth overlap.
- Bilateral Bitewing (Left and Right), which sequentially performs both bitewings, showing them on the same image.
- 3D Full Dentition (FOV 85 x 93 mm) with 3 sizes for a total of 6 combinations with automatic selection; with manual selection, it is possible to select a high voltage between 60kV and 86kV, in 2kV steps and anodic current from 2 mA to 12.5 mA in the R20 scale steps.
- 3D Single Jaw (FOV 85 x 50 mm) with two different FOV positions (Maxillary, Mandibular), and 3 sizes for a total of 12 combinations with automatic selection; with manual selection, it is possible to select a high voltage between 60kV and 86kV, in 2kV steps and anodic current from 2 mA to 12.5 mA in the R20 scale steps.
- 3D Mandibular Teeth (FOV 50 x 50 mm) with five different FOV positions (Frontal, Pre-Molars and Molars), and 3 sizes for a total of 30 combinations with automatic selection; with manual selection, it is possible to select a high voltage between 60kV and 86kV, in 2kV steps and anodic current from 2 mA to 12.5 mA in the R20 scale steps.
- 3D Maxillary Teeth (FOV 50 x 50 mm) with five different FOV positions (Frontal, Pre-Molars and Molars), and 3 sizes for a total of 30 combinations with automatic selection; with manual selection, it is possible to select a high voltage between 60kV and 86kV, in 2kV steps and anodic current from 2 mA to 12.5 mA in the R20 scale steps.
- 3D TMJ (FOV 85 x 93 mm) with two different FOV positions (R or L), 3 sizes for a total of 12 combinations with automatic selection; with manual selection, it is possible to select a high voltage between 60kV and 86kV, in 2kV steps and anodic current from 2 mA to 12.5 mA in the R20 scale steps.
- 3D Sinus (FOV 85 x 93 mm) with 3 sizes for a total of 6 combinations with automatic selection; with manual selection, it is possible to select a high voltage between 60kV and 86kV, in 2kV steps and anodic current from 2 mA to 12.5 mA in the R20 scale steps.



- 3D Extended Volumes (FOV 116 x 103 mm) with 3 sizes for a total of 6 combinations with automatic selection; with manual selection, it is possible to select a high voltage between 60 kV and 86 kV, in 2 kV steps and anodic current from 2 mA to 12.5 mA in the R20 scale steps.
- 3D Airways (FOV 116 x 103 mm) with 3 sizes for a total of 6 combinations with automatic selection; with manual selection, it is possible to select a high voltage between 60 kV and 86 kV, in 2 kV steps and anodic current from 2 mA to 12.5 mA in the R20 scale steps.

6. TECHNICAL CHARACTERISTICS

General features	
Type	X-MIND prime 3D
Manufacturer	de Götzen S.r.l. 21057 Olgiate Olona (VA) - Italy
Class	Class I with type B applied parts according to IEC 60601-1 classification. 
Protection degree	IPX0 standard device
Line voltage	99-264 V
Rated line voltage	110-240 V
Line frequency	50/60Hz
Maximum line current	14A @ 110V 50/60Hz 6A @ 240V 50/60Hz
Technical factors for maximum line current	86kV, 12.5mA
Power consumption	1.8kVA @ 110V 50/60Hz 1.4kVA @ 240V 50/60Hz
Protection fuse (F1)	20 A T 250V 6.3x32 mm 10kA@125V 8 A T 250V 6.3x32 mm 200A@250V
Column protection fuse (F2)	3 A T 250V 6.3x32 mm 10kA@125V 1.6 A T 250V 6.3x32 mm 100A@250V
Line apparent resistance	0.4 Ω max (99-132 V) 0.5 Ω max (198-264 V)
Rated output voltage (kVp)	60 – 86kVp, with 2 kVp steps
Anodic current	2 – 12.5mA, with R20 scale steps (2, 2.2, 2.5, 2.8, 3.2, 3.6, 4, 4.5, 5, 5.6, 6.3, 7.1, 8, 9, 10, 11, 12.5)
Additional filtration	\geq 2 mm Al eq.

Exposure times

Panoramic exam (PAN)	14 s Adult / 12.8 s Child
Half panoramic exam	7.7 s Adult / 7.1 s Child
Ortho Rad panoramic exam	11.5 s Adult / Child
Low dose panoramic exam	11.6 s Adult / 10.4 s Child
Frontal dentition	4.1 s Adult / Child
Bitewing Right, Bitewing Left	3.1 s Adult / Child
Bitewing Right & Left	6.2 s Adult / Child
TMJ mouth closed/open	10.6 s for left and right joint in open and closed condition
TMJ single phase	5.3 s
Sinus P/A projection	9 s
3D exams (except TMJ 3D)	7 s
TMJ 3D	6.2 s
Exposure time accuracy	± 5 % or ± 20ms whichever is greater

Exam modes

Exam selection	<ul style="list-style-type: none"> • Automatic selection for Adult and Child, 3 Sizes • 3 biting modes (Panoramic exam) • Manual selection
Panoramic exam	<ul style="list-style-type: none"> • Standard panoramic • Half panoramic L/R • Ortho Rad panoramic • Low dose panoramic • Frontal dentition • Bitewing Left/Right • Bitewing Left and Right
TMJ (Temporal Mandibular Joint) exam	TMJ open and closed mouth
Sinus	Sinus P/A projection
Volumetric 3D exams	Automatic selection for Adult and Child, 3 sizes chosen between: entire Dentition, Mandibular Dentition, Maxillary Dentition, Small Volumes (frontal, premolar, molar), TMJ Left, TMJ Right, Sinus

3D Dentition reconstructed volume

Entire volume (*)	85 mm x 93 mm (Diameter x Height)
Mandibular and Maxillary volume (*)	85 mm x 50 mm (Diameter x Height)
Small volumes	50 mm x 50 mm (Diameter x Height)
Extended volumes	116 mm x 103 mm (Diameter x Height)

(*) In case collimator kit code 6604061200 is present, the values will change to: Entire volume 80 mm x 80 mm (Diameter x Height); Mandibular and Maxillary volume 80 mm x 50 mm (Diameter x Height)

Image magnification	Geometric magnification	Magnification after software correction
Adult / Child standard Panoramic	1 : 1.28 (constant over dentition part)	1 : 1 (*)
TMJ open/closed mouth	1 : 1.25 (nominal)	1 : 1 (*)
Sinus	1 : 1.27 (nominal)	1 : 1 (*)

**(*) Warning**

The declared image magnification value is valid after proper software calibration.

**Note**

X-MIND prime 3D is based on a standard dentition and ascending rami shape. This shape, based on statistical studies, establishes a form for the dentomaxillofacial complex, adopted as "standard".

X-MIND prime 3D follows a rototranslation path which maintains the magnification factor as stated in the Technical Characteristics of each type of exam as constant along this "standard" shape only along the dentition area. The patient's anatomy can differ significantly from the statistical model, so the magnification factor is not maintained and may be different from the value stated. Based on experience and competence, the user has to judge this variation.

In any case, TMJ radiography cannot be used to perform calculations of distances, angles etc. on the film.

Tube-head characteristics

Model	MPV 05
Manufacturer	de Götzen S.r.l. 21057 Olgiate Olona (VA) - Italy
Maximum tube voltage	86 kVp
kVp accuracy	± 8 %
Maximum anodic current	12.5 mA
Anodic current accuracy	± 10 %
Duty cycle	1 : 16
Reference loading conditions related to maximum energy input to the anode	2812.5mAs/h @ 86 kVp
Nominal power	1.075 kW (86 kVp - 12.5 mA)
Total filtration	≥ 2.5 mm Al eq. @ 86 kVp
HVL (Half value layer)	> 3.2 mm Al eq. @ 86 kVp
Transformer insulation	Oil bath
Target angle and reference axis	See Figure 3
Cooling	By convection
Leakage radiation at 1 m	< 0.5 mGy/h @ 86 kVp - 12.5 mA - 3s duty cycle 1/16
Tube-head maximum thermal capacity	310kJ

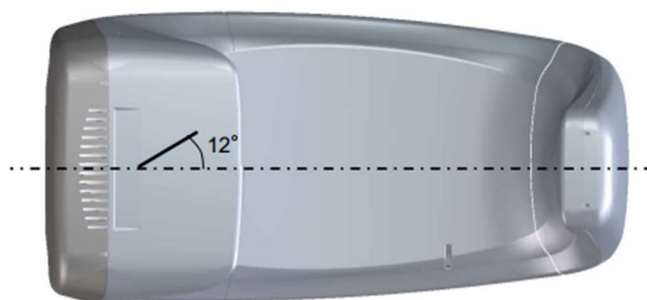

Figure 3: Tube-head target angle (view from the bottom)

X-ray tube characteristics

Manufacturer	CEI
Type	OPX 105-12
Nominal focal spot	0.5 EN 60336
Inherent filtration	0.5 mm Al eq.
Anode tilt	12°
Anode material	Tungsten
Nominal maximum voltage	110 kVp
Filament max current	4 A
Filament max voltage	6.7 V
Anode thermal capacity	30 kJ
Anode thermal capacity during continuous operation	300 W

Laser centering devices

2 laser beams are used for patient positioning; beams that align the sagittal and Frankfurt planes (please refer to relevant paragraphs for a detailed explanation).

Wave length	650 nm
Divergence	< 2.0 mRad
Optical power on the working surface	< 1 mW
Laser class	Class 2 laser product according to IEC standard 60825-1:2007

Digital sensor

Detector type	CMOS flat panel
Sensitive Area (H x L)	144 x 118.6 mm
Pixel dimensions	120 µm 240 µm (2x2 binning)
Number of pixels (H x L)	1200 x 988 600 x 494 (2x2 binning)
Voxel dimensions	175 µm HD mode 87.5 µm XD mode
Resolution (spatial frequency at CTF=5%)	4.16 lp/mm
Sensor cover attenuation equivalent	< 0.4 mm Al eq.

Mechanical characteristics

Focal spot to image receptor distance	52 cm (20")
Telescopic motorised column run	66 cm (26")
Maximum total height	219 cm (86")
Note: For the wall mount model this value refers to the recommended installation height	
Weight	67 kg base version
Column base (optional)	6 kg

Working conditions

Minimum room size (please refer to the Service Manual)	120 x 115 cm
Recommended room size (please refer to the Service Manual)	160 x 150 cm
Working temperature range	+ 10°C ÷ + 35°C
Relative working humidity (RH) range	30% ÷ 75%
Working atmospheric pressure range	700 ÷ 1060 hPa
Temperature range for transport and storage	- 20°C ÷ + 70°C
Humidity range for transport and storage	< 95% without condensation
Minimum atmospheric pressure for transport and storage	630 hPa



Note

The handles of the equipment are covered with a special antibacterial paint which, thanks to the emission of silver ions, prevents the development of micro-organisms.

6.1 Dimensions

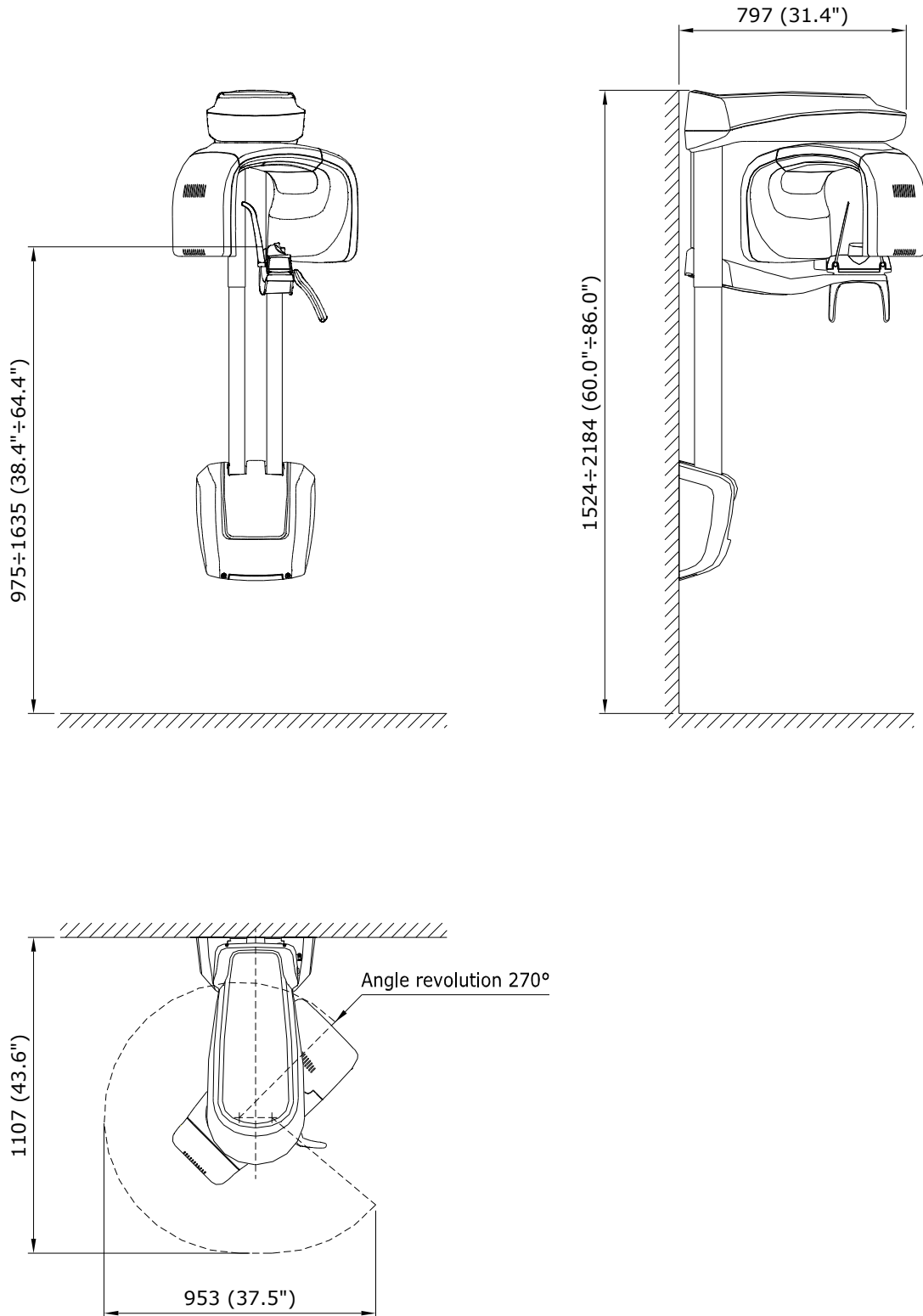

Figure 4: X-MIND prime 3D dimensions
Wall mounted version

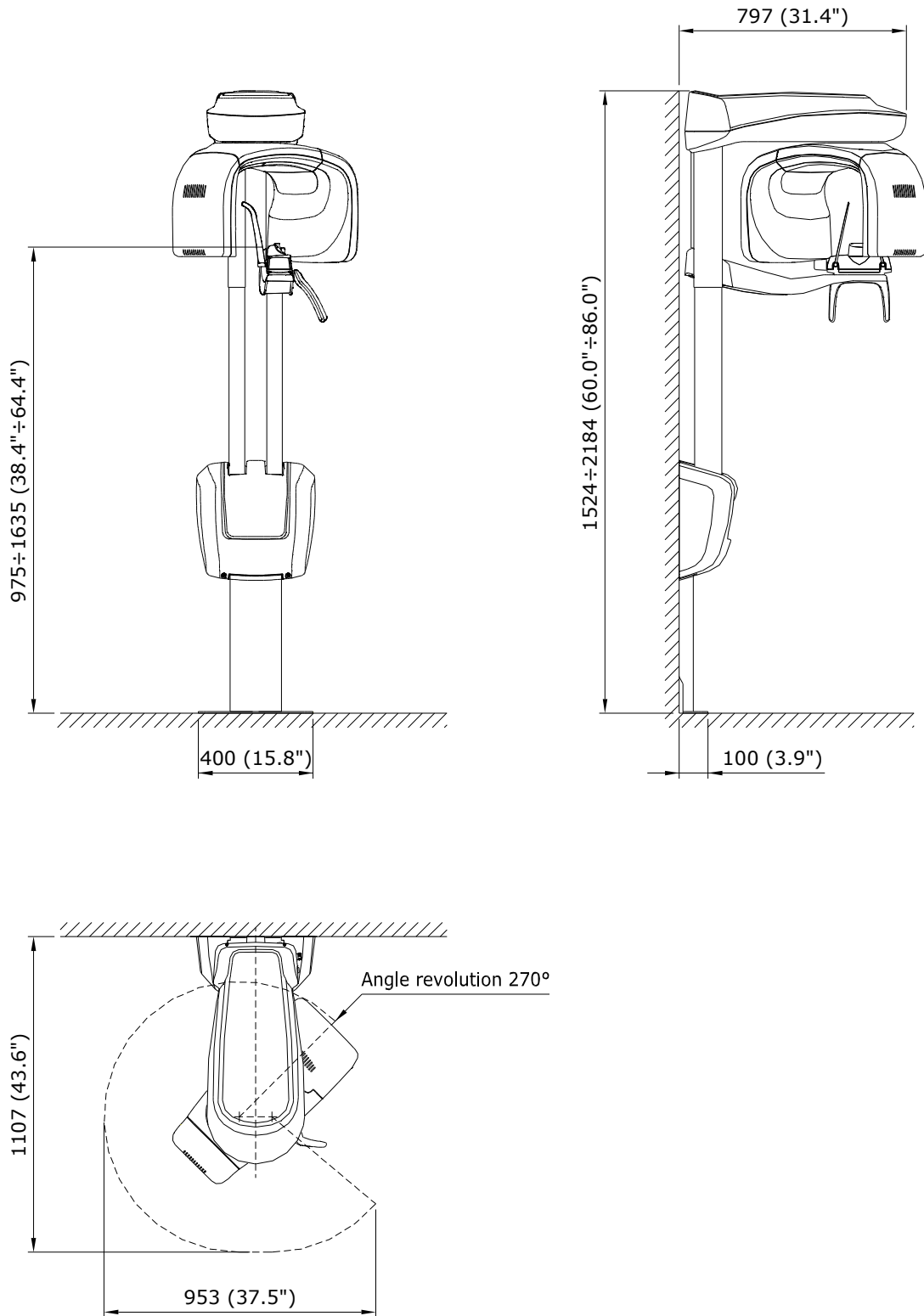

Figure 5: X-MIND prime 3D dimensions
Wall mounted with floor support version

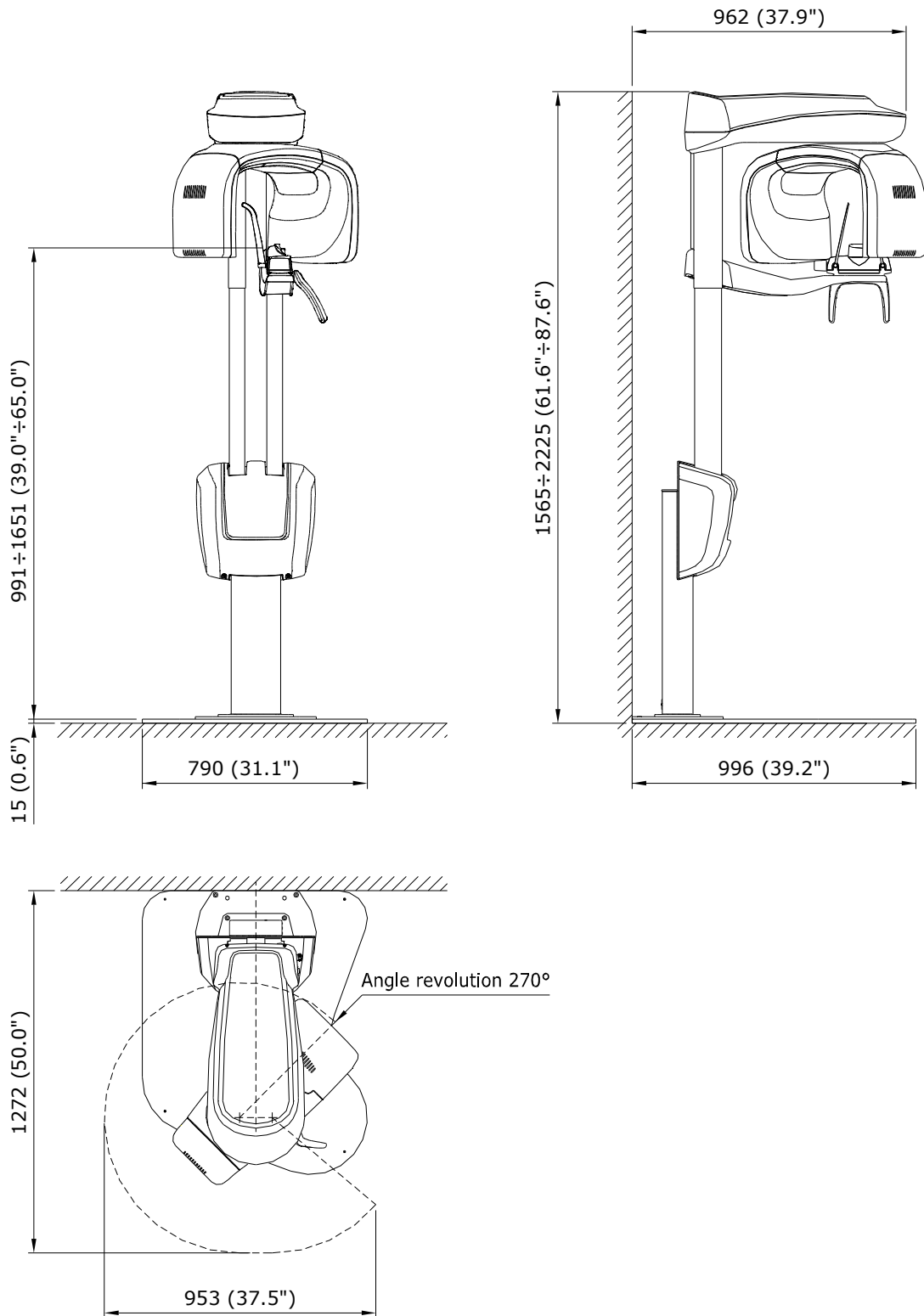
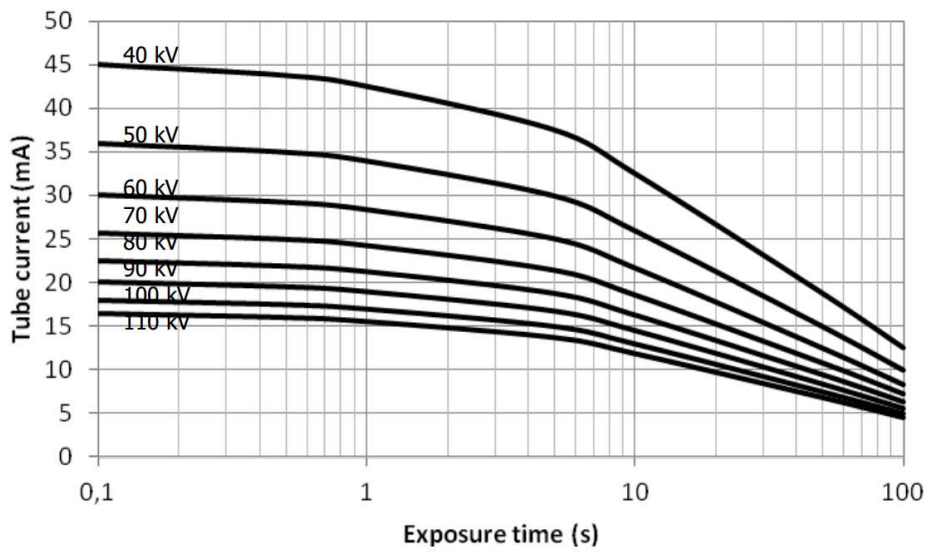

Figure 6: X-MIND prime 3D dimensions
Floor mounted version

6.2 Tube loading curves, anode heating and cooling curves

Tube "CEI OPX 105-12" (0.5 IEC 336)

Tube loading curves



Anode heating and cooling curves

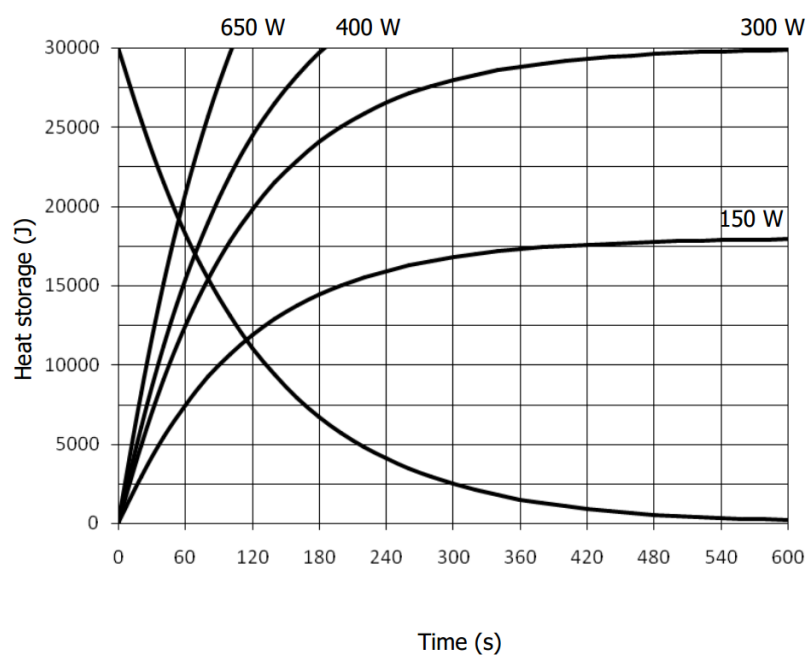

Tube head cooling curve

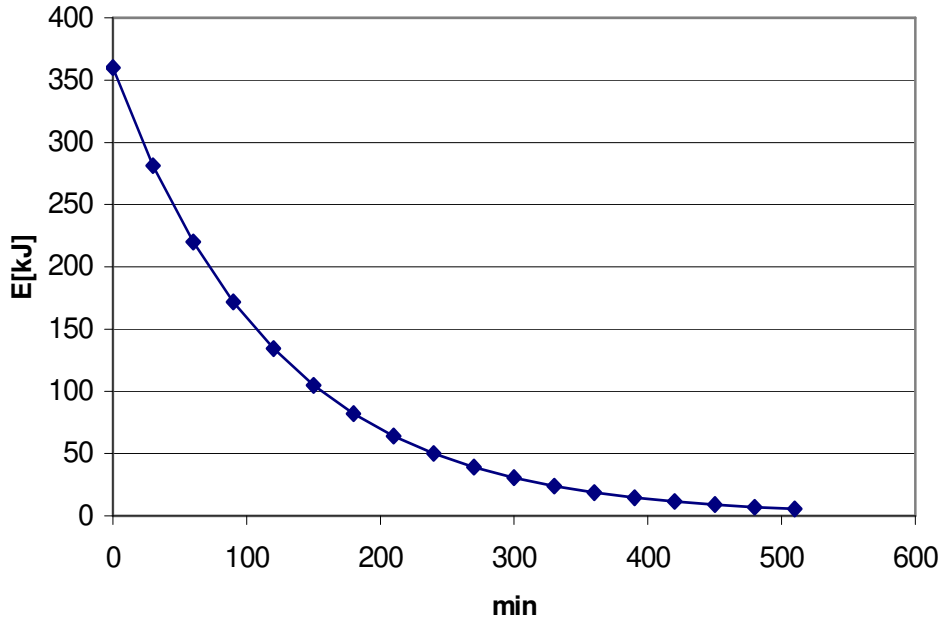

6.3 Characteristics of the supplied workstation

The workstation supplied with the equipment has the following characteristics:

- Processor Intel Core i7 (4 cores 8 threads) 3 GHz or higher.
- 8 GB RAM.
- Hard drive 1 TB.
- DVD recorder.
- GPU card with the following specifications (NVIDIA® QUADRO® P2000):
 - chipset Nvidia
 - Global memory \geq 4 GB
 - Capability (=architecture) \geq Maxwell.
- Operating System Windows 10 - 64 bit.

Monitor characteristics:

- Resolution: 1920 x 1080 pixels
- Colour depth: 16M of colour
- Contrast: 1000:1
- Luminosity: 250 cd/m²

6.4 Software

The equipment Graphical User Interface can be run with the software provided with the machine or integrated in a third party imaging and database software that complies with the following specifications: it has to be CE marked as medical device of class IIa and integrate the equipment SDK according to what stated in the document PANOW3D API programmer's guide Vn (n is the document revision), contact Acteon to have the latest revision of the programmer's document.

The 3D exams can be viewed with any software that can import, view and manage 3D volumes saved in DICOM slices with the following maximum dimensions:

- Normal resolution full volume: 532 slices, 492x492 pixels per slice, 12 or 16 bits, for a total of 484 kB/slice;
- Full resolution 80x50 volume: 542 slices, 984x984 pixels per slice, 12 or 16 bits, for a total of 968 kB/slice.

6.5 X-MIND prime 3D – PC communication

The communication between X-MIND prime 3D and computer is carried out with a LAN connection based on a TCP/IP protocol and a point to point connection between the detector and computer using an UDP protocol on a gigabit Ethernet.

In order to properly operate the unit, follow carefully the instructions reported in the Service Manual at paragraph 7.6.

The system is provided with 2 Ethernet cat 5e cables in order to permit the PC connection. In case of replacement, cables of the same or superior category have to be used.

If the communication between X-MIND prime 3D and PC is not properly set problems in unit connection causing impossibility of acquisition or loss of frames causing distortion and artefacts on the images can occur.



Note

X-MIND prime 3D is not intended to transmit or receive information to/or from other equipment through network/data couplings.

6.6 Reference standard

Medical electrical equipment for extra-oral dental radiography X-MIND prime 3D complies with:

IEC 60601 1: 2005 (3rd ed.)

Medical electrical equipment - Part 1: General requirements for basic safety and essential performance

IEC 60601 1: 2005 (3rd ed.) + Am1:2012

Medical electrical equipment - Part 1: General requirements for basic safety and essential performance

IEC 60601-1-6:2010 (3rd Ed.)

Medical electrical equipment - Part 1-6: General requirements for safety - Collateral Standard: Usability including IEC 62366: Application of usability engineering to medical devices.

IEC 60601-1-6:2010 (3rd Ed.) + Am1:2013

Medical electrical equipment - Part 1-6: General requirements for safety - Collateral Standard: Usability including IEC 62366: Application of usability engineering to medical devices.

IEC 60601-1-2:2007 (3rd Ed.)

Electromagnetic compatibility - Requirements and tests.

IEC 60601-1-2:2014 (4th Ed.)

Electromagnetic disturbances - Requirements and tests.

IEC 60601-1-3:2008 (2nd Ed.)

Medical electrical equipment - Part 1-3: General Requirements for Radiation Protection in Diagnostic X-Ray Equipment.

IEC 60601-1-3:2008 (2nd Ed.) + Am1:2013 (ed. 2.1)

Medical electrical equipment - Part 1-3: General Requirements for Radiation Protection in Diagnostic X-Ray Equipment.

IEC 60601-2-63:2012 (1st ed.)

Medical electrical equipment - Part 2-63: Particular requirements for the basic safety and essential performance of extra-oral dental X-ray equipment.

IEC 60601-2-63:2012 (1st ed.) + Am1:2017 (ed. 1.1)

Medical electrical equipment - Part 2-63: Particular requirements for the basic safety and essential performance of extra-oral dental X-ray equipment.

IEC 62366:2007 (1st Ed.)

Medical devices – Application of usability engineering to medical devices.

IEC 62366:2007 (1st Ed.) + Am1:2013

Medical devices – Application of usability engineering to medical devices.

IEC 62304:2006 (1st Ed.) + Ac:2008

Medical devices software – Software life-cycle processes.

IEC 62304:2006 (1st Ed.) + Am1:2015 (ed. 1.1)

Medical devices software – Software life-cycle processes.

IEC 60825-1:1993 (1nd ed.)

Safety of laser product – Part 1: equipment classification and requirements.

IEC 60825-1:2007 (2nd ed.)

Safety of laser product – Part 1: equipment classification and requirements.



EN-ISO 14971:2012
Medical Devices - Application of Risk Management to Medical Devices.
CAN/CSA-C22.2 No 60601-1:08
Canadian National deviations to IEC 60601-1.
CAN/CSA-C22.2 No 60601-1:14
Canadian National deviations to IEC 60601-1.
ANSI/AAMI ES60601-1:2005/A2:2010
US National differences to IEC 60601-1.
ANSI/AAMI ES60601-1:2005/(R)2012 and A1:2012
US National differences to IEC 60601-1.
CFR 21
Code Federal Regulation. Sub Chapter J.

 0051 Guarantees the compliance of X-MIND prime 3D with Directives 93/42/EEC (as amended), 2011/65/EU, 2006/42/EC.

Classifications

X-MIND prime 3D is an electrical medical X-ray device classified as class I type B according to EN 60601-1, with continuous operation at an intermittent load.

According to 93/42/EEC Medical Devices Directive, the equipment is classified as class II B.

According to Canadian MDR, the equipment belongs to class II.

According to FDA 21 CFR, the equipment belongs to class II.

6.7 CBCT Conditions of Operation

The following table lists the conditions of operation for the unit working in CBCT modality.

Quantity	Range
Tube current (mA)	from 2 to 12.5 mA
kV	from 60 to 86 kV
Exposure time	21.2 s
X-ray filtration	≥ 2.5mm Al eq. @ 86 kVp
Nominal Tomographic section thickness	0.175 mm (0.0875 mm in HR)
Image receptor area	144 x 118.6

6.7.1 Reference Plane

The reference plane offset is the horizontal plane passing on the chin rest of the unit. The Figure 7 shows the position of the reference plane and its location with respect to the chin rest, the focal spot and the irradiated volume by the x-ray cone beam. Each exam has a proper chin support that gives the proper reference plane offset.

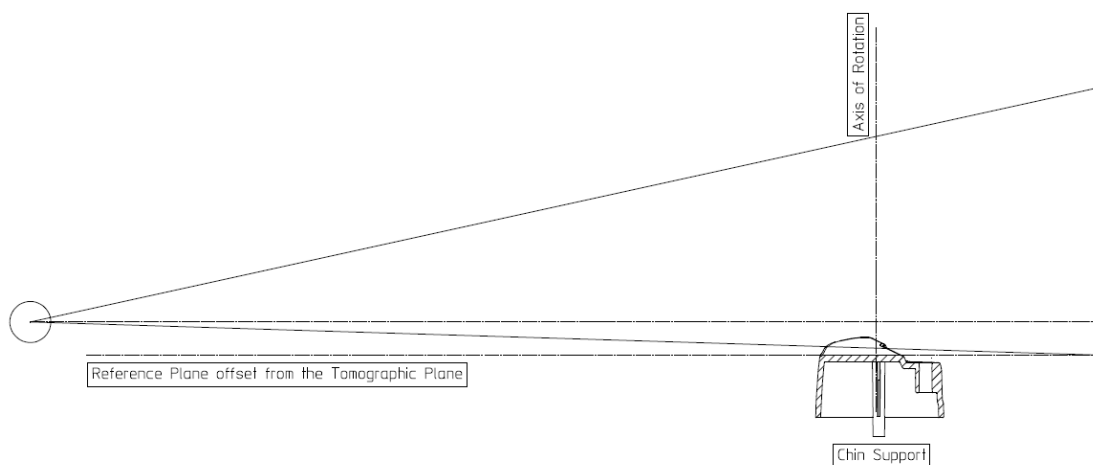

Figure 7

6.8 CTDI information

The following dose information are measured using a dosimetry head phantom compliant with the specifications of CFR 21 1020.33.

The phantom is a circular cylinder of polymethyl-methacrylate (PMMA) of density 1.19 ± 0.01 grams per cubic centimeter. The phantom is 15.0 centimeters high and has a diameter of 16.0 centimeters since the system is designed to image the head (head scanners).

The phantom has holes just large enough for the placement of a dosimeter(s) along its axis of rotation and along a line parallel to the axis of rotation 1.0 centimeter from the outer surface and within the phantom.

Values were measured as CTDI100 as recommended in the FDA Guidance doc. "Provision for Alternate Measure of the Computed Tomography Dose Index (CTDI) to Assure Compliance with the Dose Information Requirements of the Federal Performance Standard for Computed Tomography" of October 20.2006.

6.8.1 Measure conditions

The conditions of operations are set according to the following table:

Quantity	Range
Tube current (mA)	from 2 to 12.5 mA
kV	from 60 to 86 kV
Exposure time	21.2 s
X-ray filtration	≥ 2.5 mm Al eq. @ 86 kVp
Nominal Tomographic section thickness	0.175 mm (0.0875 mm in HR)
Image receptor area	144 x 118.6 mm

6.8.2 Measurement procedure

1. The phantom is placed on the support of the chin rest of the machine.
2. The dose detector is placed in the phantom in one of the positions at a time.
3. The default values for adult and normal size (84kV - 5mA) are selected.
4. An exposure is performed.
5. The dose measure is recorded.

6.8.3 Measured values

Different dose measurements are performed to find the location of the plane where the dose measurement at 1cm interior from the surface of the phantom is maximum. Such location is perpendicular to the mid-sagittal line of the imaged volume on the right side of the patient considering the patient orientation. The other Measurement Locations refer to 90° steps clockwise.

Measurement Location	Dose Value [mGy]
CDTI ₁₀₀ (CENTER)	7.7
CDTI ₁₀₀ (PERIPHERAL, MAX)	8.7
CDTI ₁₀₀ (PERIPHERAL, 90°)	2.8
CDTI ₁₀₀ (PERIPHERAL, 180°)	8.6
CDTI ₁₀₀ (PERIPHERAL, 270°)	8.6
CDTI ₁₀₀ (PERIPHERAL, AVERAGE)	7.1

weighted CDTI₁₀₀ is CDTI_w = 11.1 mGy
 volume CDTI_w is CDTI_{wi} = CDTI_w = 11.1 mGy

6.8.4 Measured Dose values for other conditions of operation

The following table lists the relative CTDI values for different conditions of operations, normalized to the value of CTDI measured in the center of the Phantom at nominal conditions of operation (84kV, 5mA, full dentition).

Conditions of Operation	CTDI Value Relative to CTDI _{100,CENTER}
60 kV	0.72
74 kV	0.91
86 kV	1.01
6 mA	0.46
8 mA	1.23
10 mA	2.23
Mandibular volume	0.57
Maxillary volume	0.57
5 x 5 small volume	0.32

The following table lists the relative CTDI values for different kV values, normalized to the maximum value of CTDI measured 1cm from the outer surface of the Phantom at nominal conditions of operation (84kV).

Conditions of Operation	CTDI Value Relative to CTDI _{100,PERIPHERAL,MAX}
60 kV (minimum value)	0.93
86 kV (maximum value)	1.00

Maximum deviation from the nominal values given in the preceding tables is $\pm 25\%$.

6.8.5 Dose profile

In the following graph the dose profile is displayed along a line z perpendicular to the tomographic plane measured in the center to the Dose Phantom.

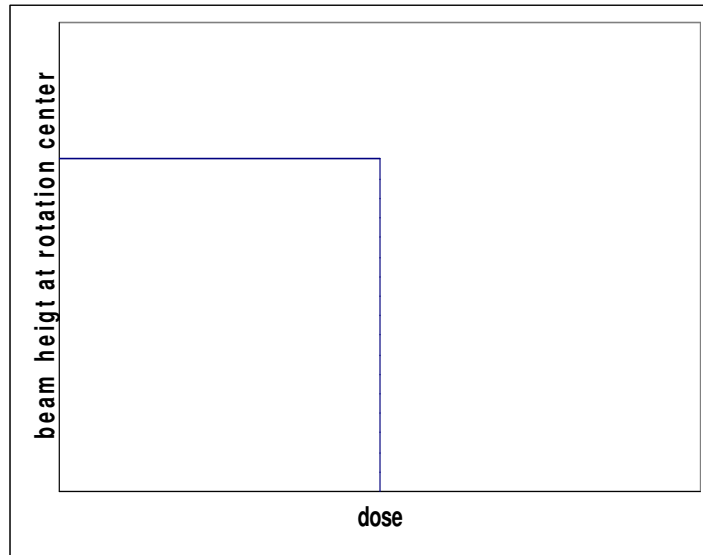

7. QUALITY ASSURANCE PROGRAM

Here following the list of the operation required to maintain the continued proper functioning of the unit:

Frequency	Type of check	Done by	Reference
Daily	Functioning of the indicator lights	User	Paragraph 7.2
Daily	Laser alignment check	User	Paragraph 7.3
Monthly	Panoramic image quality check	User	Paragraph 7.4
Six-month	3D image quality check	User	Paragraph 7.5
Yearly	Dosimetry test	Authorized personnel	Paragraph 7.6

**Note**

It is recommended to perform the quality assurance procedures either with the suggested frequency or with the frequency required by local regulations if higher.

7.1 Quality control tools

The following tools are required to perform the quality check:

- Support plate (P/N 6195170100): used to check laser alignment and to hold the centering tool (P/N 6195170200)
- Centering tool (P/N 6195170200): used to check Panoramic image quality
- 3D quality phantom (P/N 6195170000) compliant with DIN 6868-161: used to check 3D image quality
- AIS software: used to acquire image and perform measurements
- PhD_Test software: used to perform exposure without arm rotation. The PhD_Test.exe is located at C:\Program Files (x86)\Acteon Imaging\Panoramic X-MIND prime
- "QC Tool" software: used to assess 3D image quality. The software can be installed from the AIS installation media: a shortcut on the desktop will be created
- kV meter (NOT provided with the unit): used to measure exposure parameters.

All the tools are provided with the unit, except kV meter. The 3D quality phantom is provided as standard with the units for U.S. market. For the other countries, the tool is optional and has to be ordered separately.

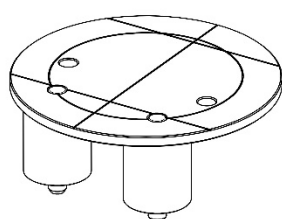

*Support plate
(P/N 6195170100)*

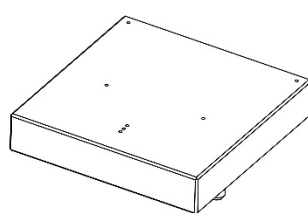

*Centering tool
(P/N 6195170200)*

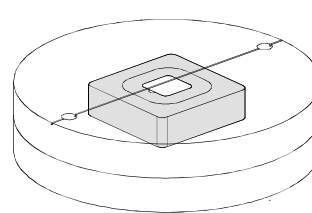

*3D Quality phantom
(P/N 6195170000)*

Figure 8

7.2 Functioning of the indicator lights

Power ON the unit, verify that the "Machine Ready" (1), "X-Ray Emission" (2) and "Computer connection" (3) LEDs blink twice.



Figure 9

In case the test fails, verify that the main power supply is present in the room. If the case, call technical assistance.

7.3 Laser alignment check

Power ON the unit and perform the axis reset by pressing the >0< button.

At the end of the axis positioning, select standard Panoramic exam (see paragraph 11.1) and press >0<. Place the support plate (P/N 6195170100 - Figure 11) on the chin rest support and power ON the laser. Check that the mid-sagittal laser beam is aligned to the reference line of the support plate ($\pm 3\text{mm}$).

At the end of the check, switch OFF the unit.

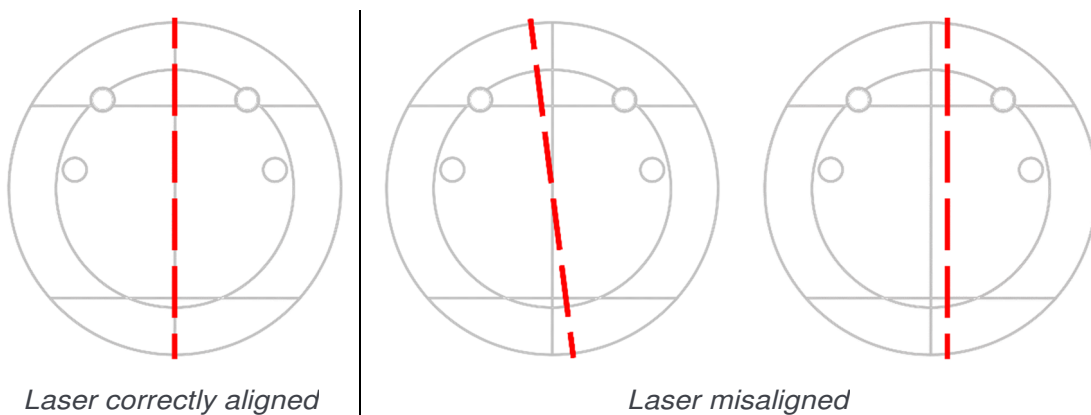

Figure 10

In case the test fails, repeat it checking that there is no mechanical interference. If misalignment is still present, call technical assistance.

7.4 Panoramic image quality check



Warning

X-rays will be emitted during the performance of the following operations. It is recommended to use the greatest caution and to comply with local safety regulations and laws.

1. Switch ON the unit (see paragraph 1).
2. Open AIS software and open the patient "Quality Test". If not present, create a new patient (Last name: "Quality"; First name: "Test").
3. From the top toolbar, select the Panoramic icon to open the X-MIND prime interface.

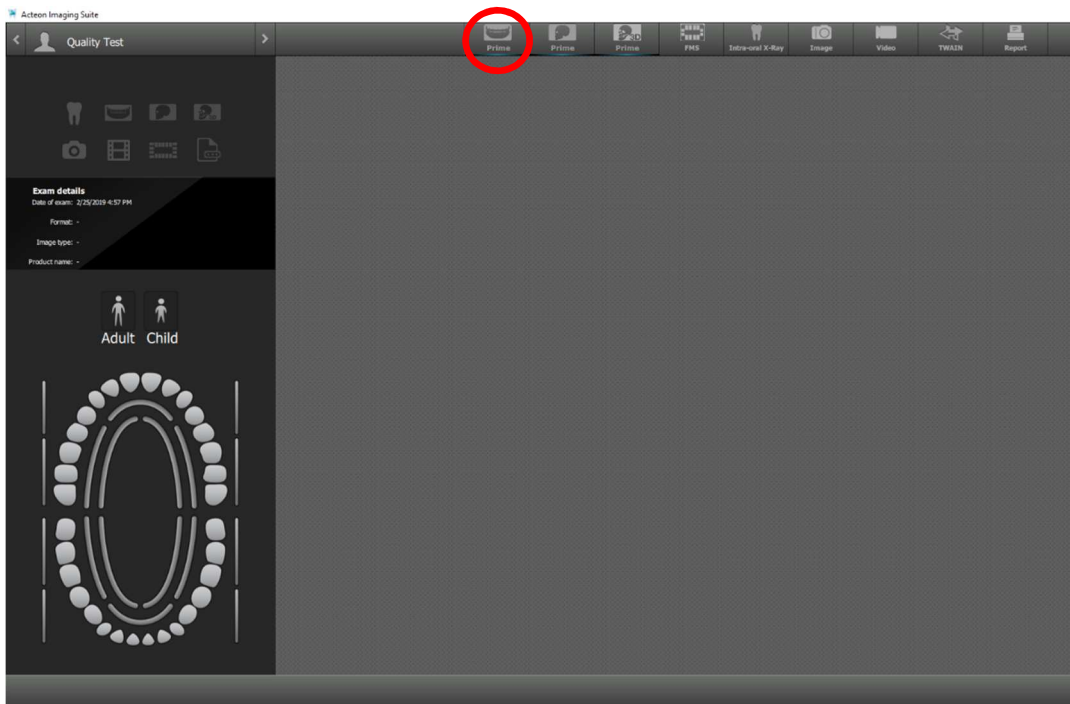

4. Mount the centering tool on the support plate and place it on the chin rest support.

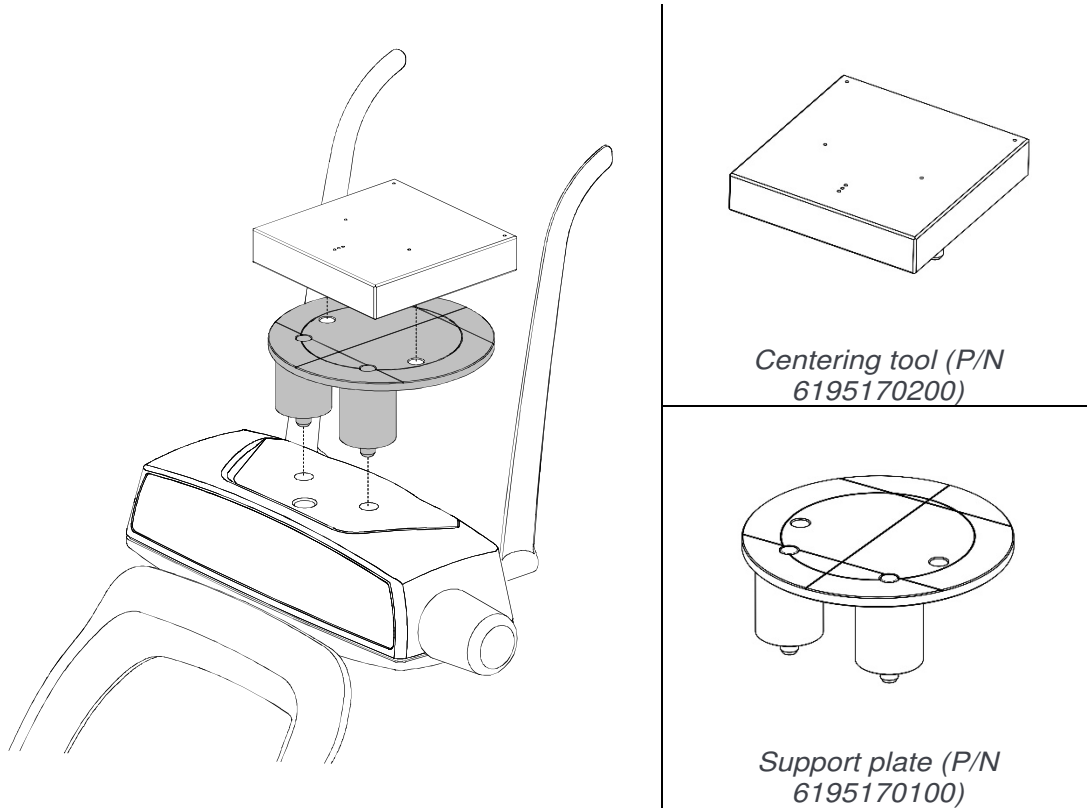
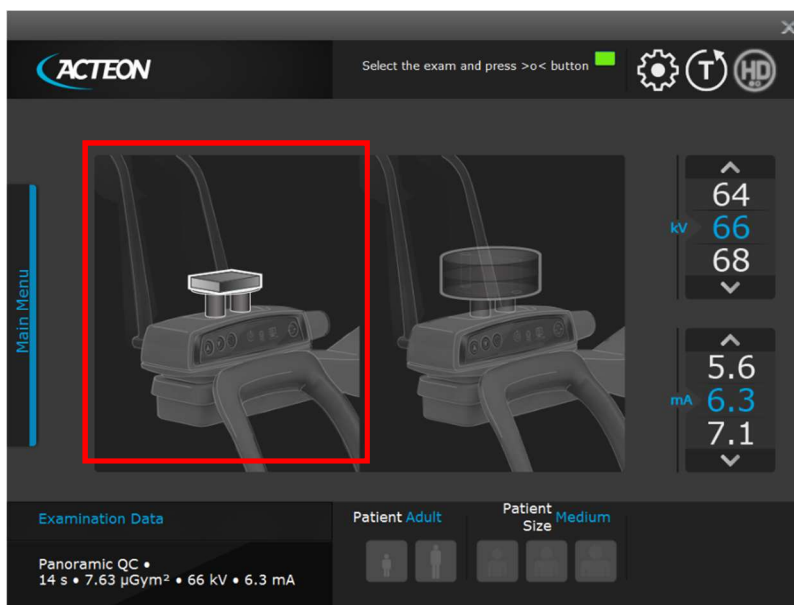
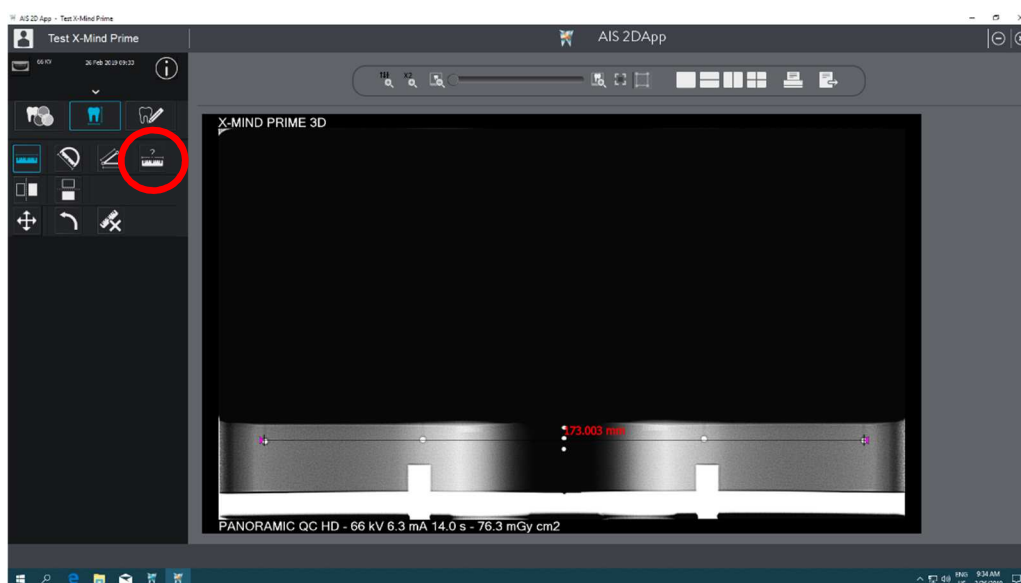

Figure 11: Support plate and centering tool positioning

5. On the main menu of the virtual interface, select "Quality Test" exam, the following image will be displayed:



6. Select "Panoramic QC" exam clicking on the left area of the virtual interface.
7. Make an exposure at 66kV, 6.3mA (see chapter 9).
8. Close the X-MIND prime interface
9. Double-click to open the acquisition
10. Select the "Measurements" icon and measure the distance between the two external spheres; this value must be $173\text{mm} \pm 2\text{mm}$.



In case the test fails, call technical assistance.

11. Measure the distance between the left external sphere and the central one and the distance between the right external sphere and the central one: the difference of these values must be maximum 2mm.
In case the test fails, call technical assistance.
12. Record the tests results in the log book at paragraph 7.4.1.



7.5 3D image quality check

The 3D image quality check is based on the usage of the 3D quality phantom (or equivalent) and the software "QC tool".

The phantom consists of discs of PMMA with inclusions of different materials (PVC and Air) for performing the required measurements. After the image acquisition, the volume is exported in DICOM format from the imaging program into the "QC tool".

The following paragraphs describe the tests to be performed for 3D image quality test.

7.5.1 "QC Tool" software

The "QC Tool" software can be started either from the desktop shortcut or directly from AIS by right clicking on the acquired 3D test image as described below. After each test, record the measurements in the logbook provided in paragraph 7.5.12. At the end of the test a report can be exported in .pdf and .csv format.

Once the 3D acquisition of the quality phantom is imported in the QC tool, a new test can be started by clicking on "Start Quality Control Test".

In the first page of the QC tool the user can configure the test, by specifying the following information:

- Device
- Phantom used
- Tester information
- Practitioner information
- Type of test (Acceptance/Constancy)
- Local regulation.

Once the test is set up, it can be started by clicking on "Start test".

The QC tool user interface is divided in the following areas:



Figure 12

1. Image viewer
2. Slice number
3. Name and description of the current measure
4. Measured value
5. Example image which shows how to perform the measurement
6. Button to proceed/skip to the next measure

At the end of the test, click on "Save test" in order to save the result. The result of past test can be accessed from the main page of the QC tool by clicking on "Past tests". A test report can be generated by clicking on "Export test report". The report will be exported in two file formats: .pdf and .csv.

Record the measurements in the logbook provided at paragraph 7.5.12.



Note

In case you find any value out of the acceptable range, please call your service representative for a system inspection.

7.5.2 3D test image acquisition

In order to acquire the 3D image needed for the quality test, create (if not present) a patient "Quality Test" and perform the following steps:

1. On the main menu of the virtual interface, select "Quality Test" exam, the following image will be displayed:

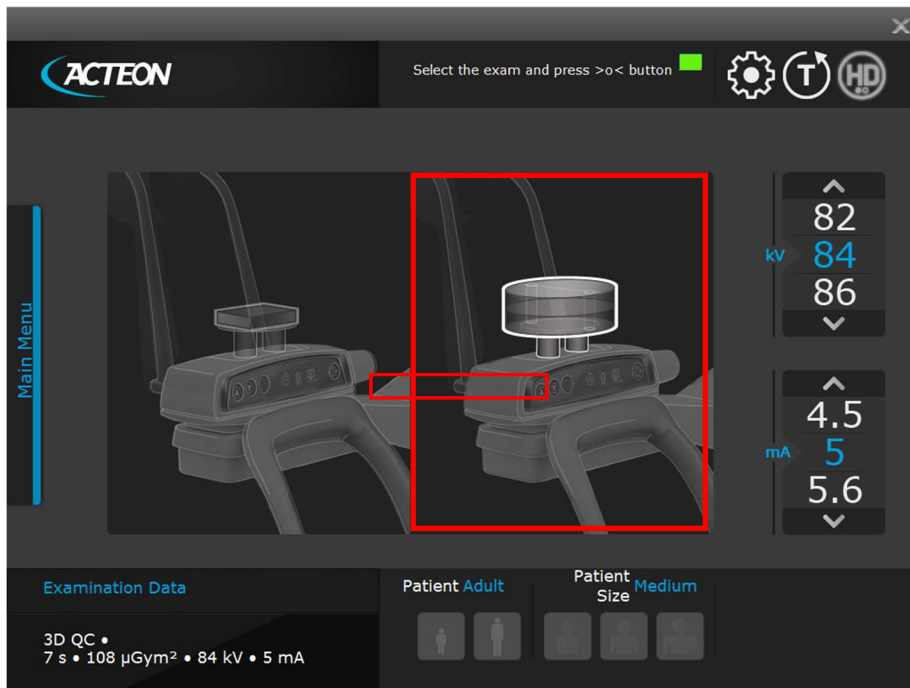

2. Select "3D QC" exam clicking on the right area of the virtual interface.
3. Place the support plate on the chin rest and place the 3D quality phantom on the plate, in such a way as the reference central line is on the top.

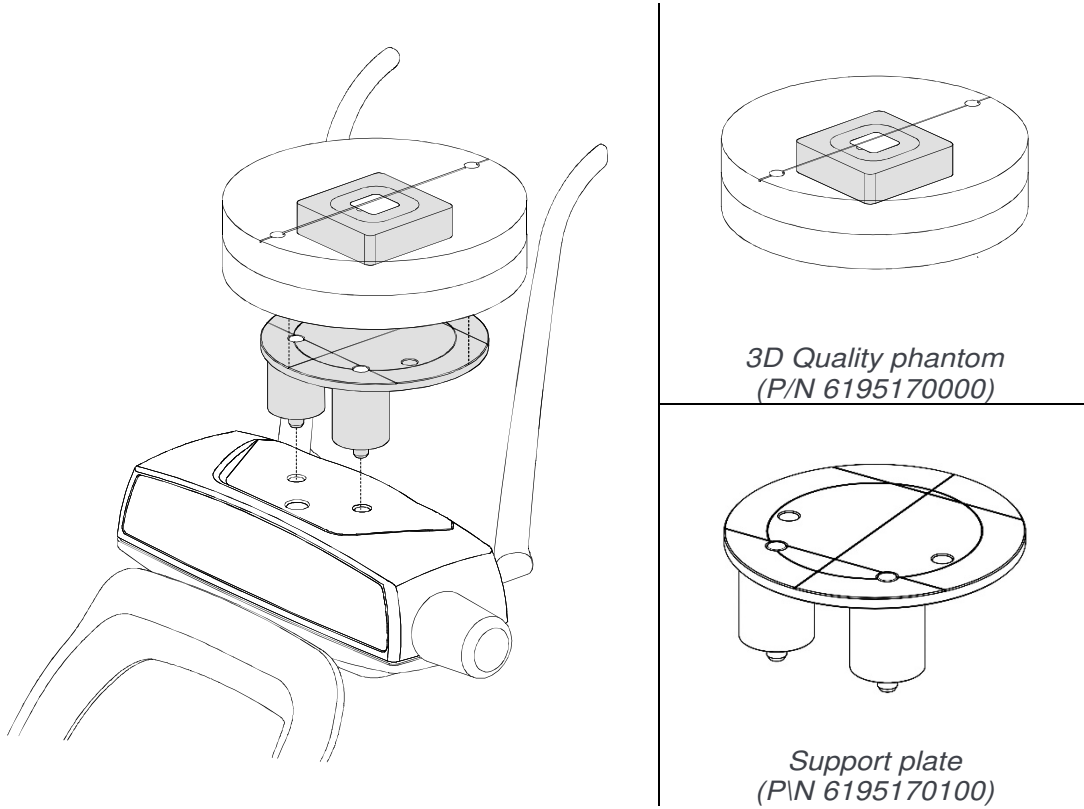

Figure 13

4. On the PVC insertion is present a position reference; this reference must be positioned towards the keyboard side.

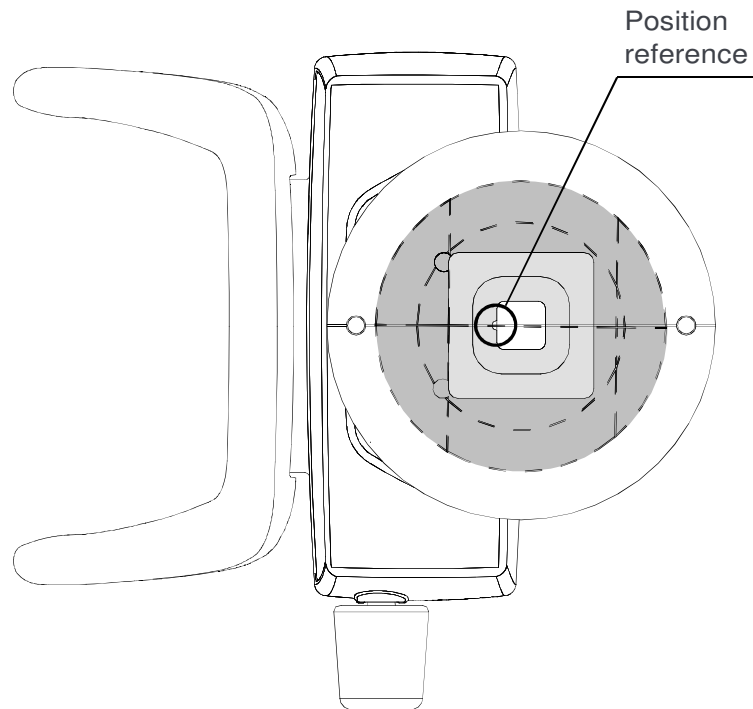

Figure 14

5. Press the button ">O<" on the keyboard to run the chin rest automatic positioning.
6. Switch ON the laser and move the phantom in order to align its reference central line to the sagittal plane; the PVC insertion must be centred inside the internal circle of the support plate.
7. Press the button ">O<" on the keyboard and make an exposure at 84kV, 5mA.
8. Right click on the acquired image and select "Export to QC Tool" from the drop-down menu.

7.5.3 Nyquist frequency

Verify that the displayed image looks like the following:

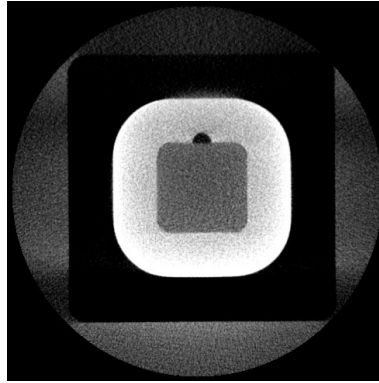

Figure 15

Left click and drag to draw an area as shown in the example picture on the right panel (5 - Figure 12).

Verify that the Nyquist frequency value displayed is greater or equal to 1. Report this value in the "Nyquist frequency" cell of the QC log book at paragraph 7.5.12.

7.5.4 Contrast to noise ratio

Click on "Next measure" button (6 - Figure 12) to proceed with the "Contrast to noise ratio" test, which gives information about noise performances.

The image will be loaded automatically; left click to place an area as shown in the example picture on the right panel (5 - Figure 12).

Two values are displayed:

- Contrast to Noise Ratio: verify that the displayed value is greater or equal to 4. Report this value in the "Image noise" cell of the QC log book at paragraph 7.5.12
- Contrast: verify that the displayed value is greater or equal to 400. Report this value in the "Low contrast resolution" cell of the QC log book at paragraph 7.5.12.

7.5.5 Spatial resolution

Click on "Next measure" button (6 - Figure 12) to proceed with the "Modulation Transfer Function" test, which gives information about spatial resolution.

The image will be loaded automatically. Left click to place an area as shown in the sample picture on the right panel (5 - Figure 12).

Two values are displayed, which are characteristic points of the Modulation Transfer Function expressed in lp/mm:

- MTF_{10%} - spatial frequency at which the frequency response is 10% of the maximum value. This value must be greater or equal to 1 lp/mm
- MTF_{50%} - spatial frequency at which the frequency response is 50% of the maximum value.

Report the values in the "MTF 10%" and "MTF 50%" cells of the QC log book at paragraph 7.5.12.

7.5.6 CT number

Click on "Next measure" button (6 - Figure 12) to proceed with the "CT number" test, which gives information about the CT number of the different materials within the volume. The image will be loaded automatically, left click and drag to draw an area as shown in the example picture on the right panel (5 - Figure 12).

The mean and standard deviation of the gray levels inside the area are displayed. The mean value must be in the range from -100 to +100 HU.

Report this value in the "CT number" cell of the QC log book at paragraph 7.5.12.

7.5.7 Length and width measures

Click on "Next measure" button (6 - Figure 12) to proceed with the "Length and width" test, which gives information about the geometry of the 3D reconstruction in the tomographic plane.

The image will be loaded automatically, left click and drag to draw an area as shown in the example picture on the right panel (5 - Figure 12).

Both measures have to be in the range from 54.0mm to 66.0mm (nominal 60mm).

Report these values in the "Length measure" and "Width measure" cells of the QC log book at paragraph 7.5.12.

7.5.8 Slice thickness

Click on "Next measure" button (6 - Figure 12) to proceed with the "Slice thickness" test, which gives information about the geometry of the 3D reconstruction along the z axis. The image will be loaded automatically, left click and drag to draw an area as shown in the example picture on the right panel (5 - Figure 12).

Verify that the Slice thickness value displayed is in the range from 15.3mm to 18.7mm (nominal 17.0mm).

Report these values in the "Slice thickness" cell of the QC log book at paragraph 7.5.12.

7.5.9 Homogeneity

Click on "Next measure" button (6 - Figure 12) to proceed with the "Homogeneity" test which gives information about the uniformity of the reconstruction. The image will be loaded automatically: verify that the displayed image looks like the following:

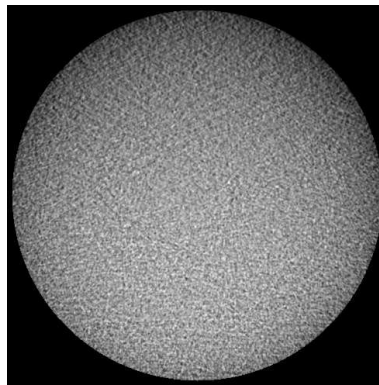

Figure 16

The measurement will be performed automatically. The Homogeneity value must be greater or equal to 5.

Report these values in the "Homogeneity" cell of the QC log book at paragraph 7.5.12.

7.5.10 Dose at the isocenter

**Note**

Perform this test only if required by local regulation.

For this analysis three dose measurements are required. The dose measures must be taken in free air, with the dosimeter as close as possible to the image receptor plane and the exposure parameters set to Full Dentition 3D, Adult patient, Medium size. The dose values should be expressed in mGy.

Two values are computed starting from the three dose measures:

- dose at the isocentre: dose computed in the center of rotation, where the patient is, according to the geometry of the machine
- dose maximum aberration: index of the dose reproducibility, expressed as percentage deviation from the mean value.

7.5.11 Acceptance index

In the last section an index is displayed summarizing the quality of the 3D image with respect to the given dose.

It is computed starting from the quality parameters previously measured: Contrast to Noise Ratio, $MTF_{50\%}$ and Dose at the isocentre. The index is expressed in $1/(mGy \cdot cm^2)$.



7.5.12 Log book

Pass Criterion	DATE
> 1	Nyquist frequency
$CNR \geq 4$	Image noise
Contrast > 400	Low contrast resolution
MTF 10% ≥ 1	High contrast resolution
MTF 50%	
Mean value of HU [-100 ÷ +100]	CT number
54.0mm ÷ 66.0mm	Width measure
54.0mm ÷ 66.0mm	Length measure
15.3mm ÷ 18.7mm	Slice thickness
≥ 5	Homogeneity
--	Dose at isocentre
--	Dose max aberration
≥ 100 1/(mGy·cm ²)	Acceptance Index

7.6 Dosimetry test (paragraph for authorised personnel)



Note

The dosimetry test has to be performed only by authorized personnel. The present paragraph explains the procedure for dosimetry test with non-invasive method. For further details, please refer to Service Manual.

1. Place the probe of the dosimeter on the center of the sensor area (black rectangle on the sensor plastic cover).
2. Open the PhD_Test software (located at C:\Program Files (x86)\Acteon Imaging\Panoramic X-MIND prime) and check that the unit is connected to the PC (the message "MCU is connected" is displayed in the bottom left corner of the program window).
3. From the "Exam parameters" panel select the ID as "Centring 3D". Select format as "W01 - 86x90 full 3D".

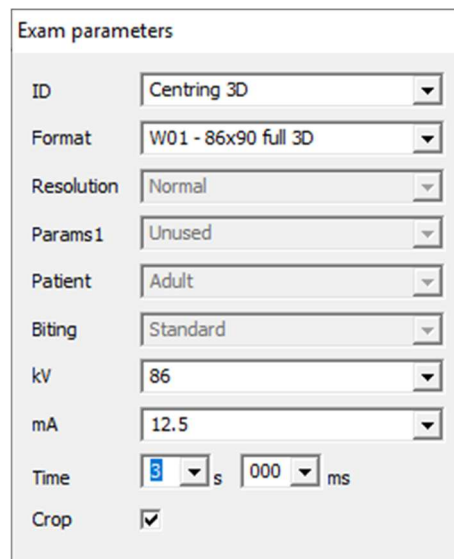

Exam parameters	
ID	Centring 3D
Format	W01 - 86x90 full 3D
Resolution	Normal
Params1	Unused
Patient	Adult
Biting	Standard
kV	86
mA	12.5
Time	3 s 000 ms
Crop	<input checked="" type="checkbox"/>



Note

The "Centring 3D" choice allows you to carry out the dosimetry test without the rotation of the tube-head arm.

- In the "Sensor centring parameters" panel set the following exposure parameters: 60 kV, 2 mA, 3 s.

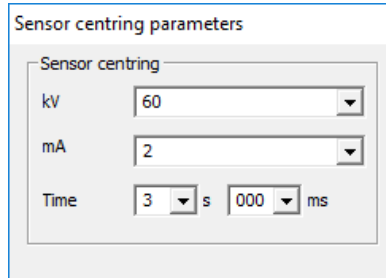

- Press the X-ray button to take an exposure and verify that the measured values are in the acceptance limits listed in the Table at point 6.
- Take a second exposure setting the following parameters: 86 kV, 12.5 mA, 3 s and verify that the measured values are in the acceptance limits listed in the following table.

kV	mA	t (s)	kV acceptance limits	Time acceptance limits
60	2	3	55.2 to 64.8 kV	2.85 to 3.15 s
86	12.5	3	79.1 to 92.8 kV	2.85 to 3.15 s

- In case the test fails (result do not match the indicated values), proceed with the following actions:
 - Check the probe position and repeat the test
 - If the values are still out of range, perform the test using the invasive method as described in the Service Manual
 - If the values are still out of range, call technical assistance.
- Record the test results in the log book at paragraph 7.6.1.

8. GENERAL INSTRUCTIONS FOR USE

8.1 Switching the device ON and OFF



Warning

The unit must be connected to a differential magneto-thermal switch to divide the unit from the supply. This switch must comply the electrical regulations in force in the country of installation.

Minimum requirements at 230V: working voltage 250V, current 10A and differential current 30 mA.

Minimum requirements at 115V: working voltage 150V, current 25A and differential current 30 mA.

Press the power switch located on the upper part of the equipment on the operator side to position "1".

This will start the "CHECK" function, which is indicated by LEDs lighting up on the equipment keyboard.

When the "CHECK" function is complete, the green LED (3 - Figure 17) on the equipment keyboard starts blinking.

To carry out an exam (see also chapter 9):

1. Press ">O<" button on the keyboard to run the equipment axis zero.
2. Run the "GUI" on the PC and wait for the connection between the PC and the equipment; this status is indicated by the blue LED on the equipment (5 - Figure 17) and on the GUI lighting up.
3. Select the exam and parameters on the GUI.
4. Press the button ">O<" on the keyboard to run the chin rest automatic positioning accordingly with the current exam selection. The white LED (8 - Figure 17) will starts blinking (system waiting for a user's input).



Note

At this moment is no longer possible to change the exam type through a direct selection on the GUI. In order to undo the current selection:

- press the button ">O<" two times to reset the current chin rest position.
- make a new exam selection on the GUI.

5. Place the proper chin rest relating to the current exam selection. If the chin rest is correct, the white LED will become steady on, otherwise it will blink quickly.
6. Position the patient.
7. Press ">O<" button to set up the equipment in the start exam position; the green LED lights up.

The unit is now ready for exams. To run the exam, press the X-ray button and keep it pressed until the exam end.

**Warning**

Since the X-ray button is a "dead man's switch", its release before the end of the exposure, immediately stops the X-ray emission and the arm rotation. Error 362 or Error 760 will be displayed.

**Note**

In the start exam position, the laser light and column movement are not enabled, and on the GUI only kV and mA adjustment is allowed.

**Note**

Ready for X-ray status is signalled by the green LED on the equipment (3 - Figure 17) and on the GUI lighting up. Ready for X-ray status remains as long as the equipment is in the start exam position and the GUI is connected to the equipment.

To switch OFF the unit press the power switch located on the upper part of the equipment on the operator side to position "0". The LEDs will go off.

8.1.1 Emergency button

The equipment has a red emergency button located on the upper part of the unit, near the power switch.

The emergency button only stops the vertical column movement.

In case of an emergency column situation, press the emergency button to stop the movement.

If columns don't move, check that the emergency button is not pressed; rotate the button to release it.

8.2 Positioning the chin support

X-MIND prime 3D is equipped with different types of supports:

- a standard support fitted with a special removable appendix for edentulous patients
- a tiniest support fitted with a special removable appendix for edentulous patients
- a dedicated support for 2D TMJ exams (Open/Closed mouth).

The standard chin rest (code 6104011519) must be used on 2D Panoramic, 3D Full Dentition, Extended Volumes, 3D Single Jaw Mandibular and 3D Mandibular Teeth modes, with all patients who can ensure a tight grip on the centring bite. The appendix for edentulous patients (code 5407098119) must be applied only for patients who cannot ensure a tight grip on the bite or are not co-operating and might move during the exam.



The tiniest chin rest (code 6104011619) can be used with bite (code 5407098200) or with appendix for edentulous (code 5407098119) on 3D Maxillary Teeth and 3D Single Jaw Maxillary by following the above criteria; it must be used always with appendix for edentulous on 2D and 3D Sinus and 3D TMJ L/R.





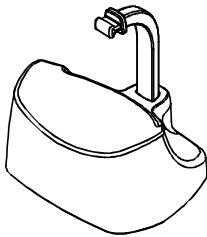
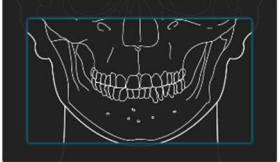
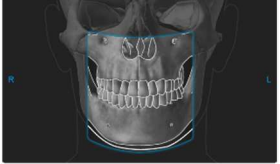
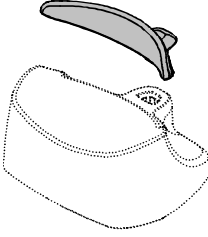
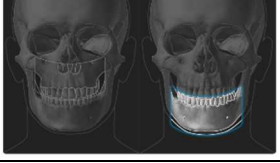

For 2D TMJ exams, a specific positioner (code 6107099800) is included, allowing the patient to open and close the mouth without touching any positioner with the chin.

Note

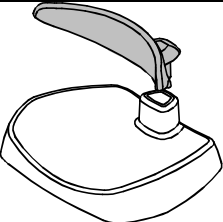
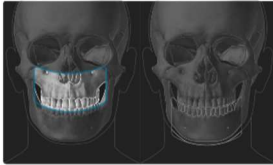
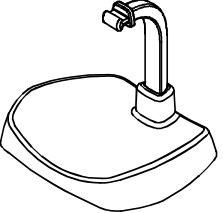

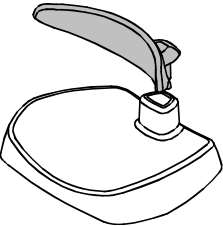
Another chin support (code 6104011719), lower in height, can be used in standard panoramic exams to ensure a better view of the lower section of the chin for patients with a particular anatomy. This chin support is marked by a down arrow "▼" on the front of the chin support itself.

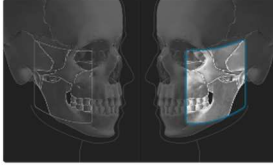
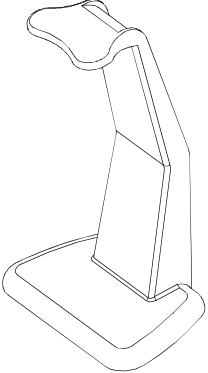
		<p>2D Panoramic & Bitewing</p>
<p>6104011519 + 5407098200</p>		<p>3D Full Dentition and Extended Volumes</p>
		<p>3D Single Jaw - Mandibular</p>
<p>5407098119</p>		<p>3D Mandibular Teeth - Frontal / Premolar / Molar</p>

 <p>6104011619 + 5407098119</p>		<p>3D Single Jaw - Maxillary</p>
 <p>6104011619 + 5407098200</p>		<p>3D Maxillary Teeth - Frontal / Premolar / Molar</p>
 <p>6104011619 + 5407098119</p>		<p>2D Sinus</p>
		<p>3D Sinus</p>
		<p>3D TMJ</p>
 <p>6107099800</p>		<p>2D TMJ O/C</p>
		<p>2D TMJ Single phase</p>

Temple clasps and strip must be always used to block the patient's head.

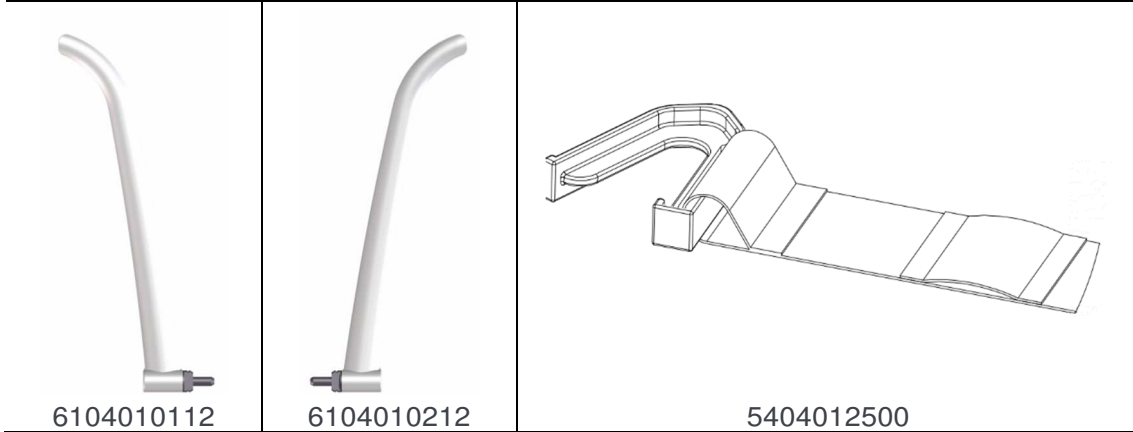

8.3 Keyboard - Description and functions

Figure 17 shows a general view of X-MIND prime 3D control Interface.

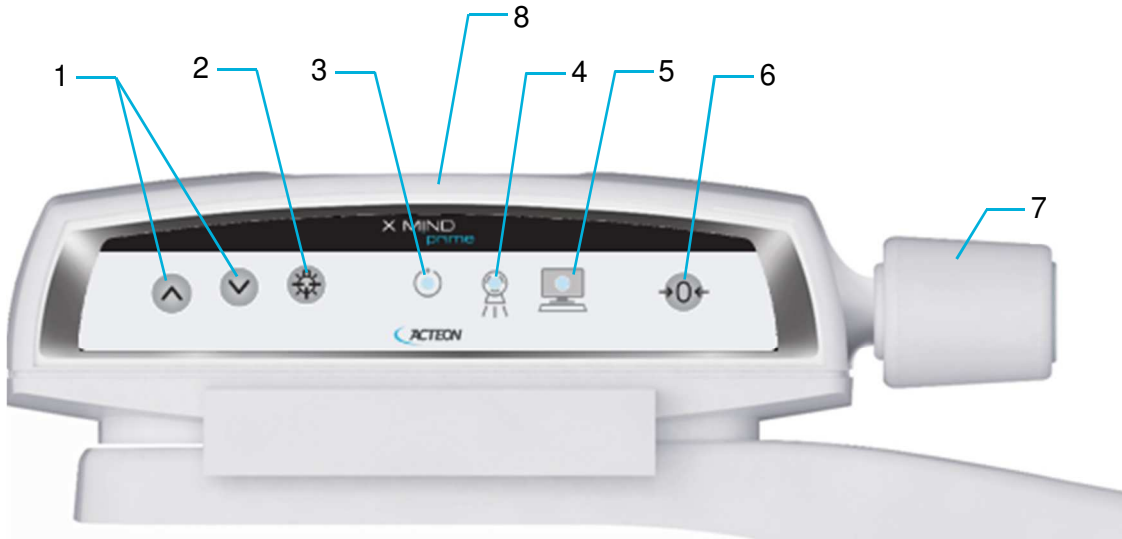









Figure 17 - Keyboard

Label	Description	
1	The up/down movement of the column is controlled by the corresponding keys. The movements are enabled during equipment setting. Column movement is not possible if the emergency button is pressed.	
2	The "Luminous centring device" key turn the laser centring devices ON/OFF, allowing the correct positioning of the patient.	
3	Light indicator of "Machine Ready" status: <ul style="list-style-type: none"> • Green fixed, alerts the user that by pressing the X-ray button, X-ray emission will start • Green blinking slowly, indicates that by pressing >0< button, axis reset will start • Green blinking fast, indicates the equipment cooling status. 	
4	Light indicator "X-Ray Emission" status. It indicates the emission of X-rays.	

Label	Description	
5	Light indicator of "Computer connection" status: <ul style="list-style-type: none"> • Blue fixed, computer connection established • Blue blinking slowly, waiting for computer connection. No X-ray emission available • Blue blinking fast, the equipment is in error state. Refer to the GUI for error description. 	
6	The "Centring/Patient Entrance" key is used to: <ul style="list-style-type: none"> • Start/Stop the exam procedures • Put the rotation arm in the patient entrance position at the end of the exam. 	
7	Temple clasps closing/release knob.	
8	Chin rest control LED: <ul style="list-style-type: none"> • White fixed, the chin rest is correct for the selected exam • White blinking, the chin rest is not present or not correct for the selected exam 	

8.4 Graphical User Interface - Description and functions

All unit configuration is managed via the virtual interface (Figure 18) running on the computer. This interface enables the user to configure all technical features of the unit, to choose and adjust the exam and radiological parameters.

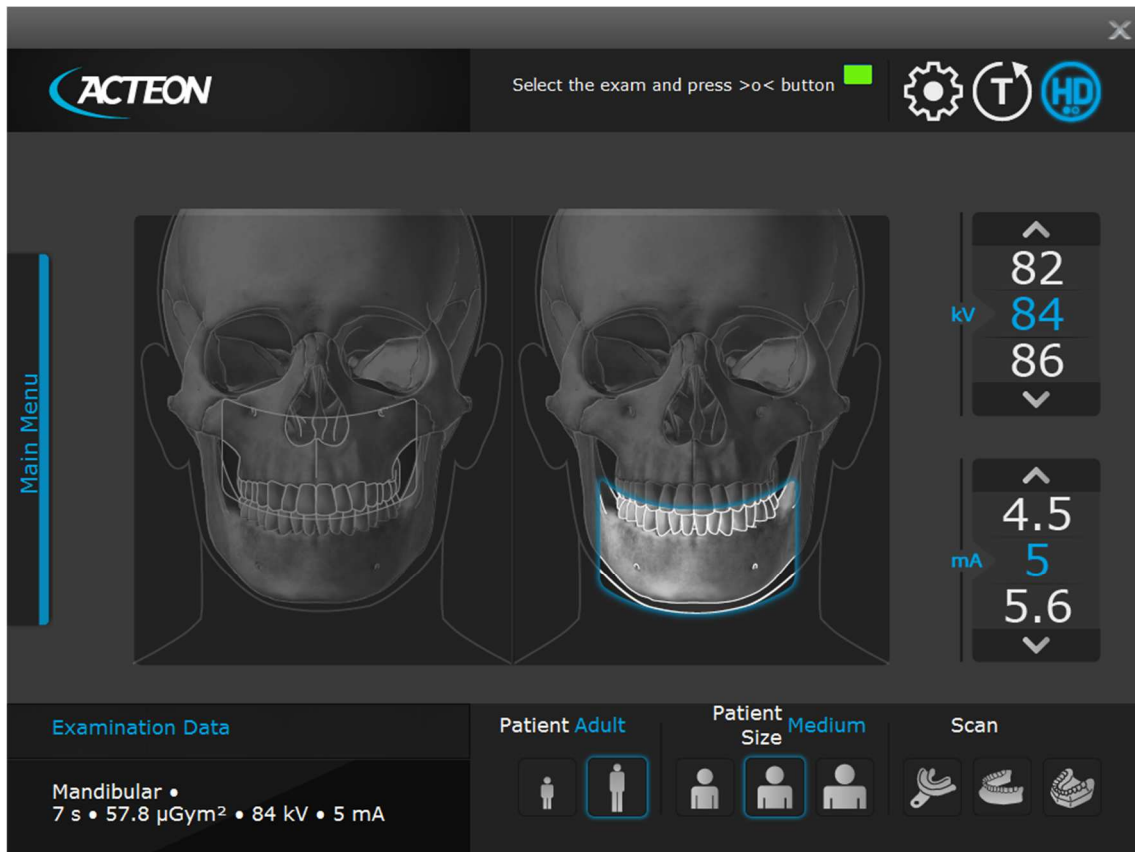



Figure 18

<p>Adult/Child selection: the pre-set exposure values and in panoramic exam the trajectory, are automatically updated based on the current selection.</p>	
<p>Patient size selection: Small/Medium/Large. The pre-set exposure values will be automatically updated based on the current selection.</p>	
<p>Patient's type of biting: Protruded/Normal/Retracted. This selection is only available in Panoramic mode. The position of the focus layer will be automatically updated based on the current selection.</p>	

<p>Test mode selection: disables X-ray emission. Use the test mode to check for the absence of collision with the patient. Test mode may also be useful when the equipment is used on child patients, to show them how the equipment works before running the exam.</p>	
<p>Setting: open the setup menu.</p>	
<p>HD (High Definition mode) / XD (eXtra Definition mode) selection.</p>	
<p>Virtual LED: indicates the current status of the unit: Blue = Initialization Green = Ready Red = Error Yellow = X-Ray emission</p>	
<p>Exposure parameters selection: changes kV and mA. When the exposure parameters are manually changed, the mode indicator switches from "Anatomic" to "Manual". Return to "Anatomic mode" using the main programme selection key.</p>	
<p>Main menu: selects exam modality, exam type and sub-menu including the available exams.</p>	

8.4.1 Main GUI area functions

Click on Main Menu to open the exam selection list. After selecting the exam mode (i.e. Panoramic), the user can choose further options (i.e. Half Panoramic Left).

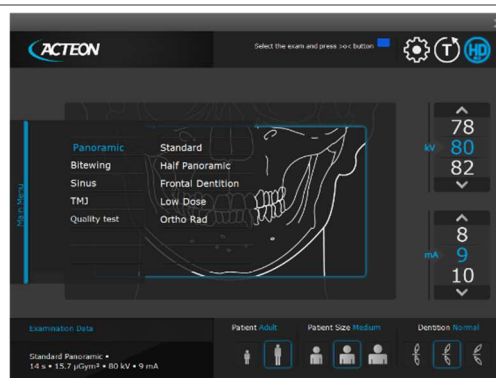

In the main area of the Virtual Interface the anatomical region matching the current selection is displayed. In case of multiple options available (for instance 3D Single Jaw Maxillary / Mandibular) the final selection can be made by clicking to the corresponding active area on the image.

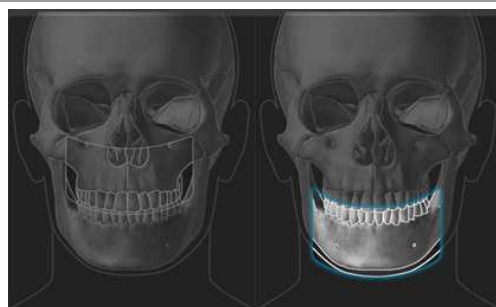

The user can choose from different options.

- Adult/Child: the correct pre-set exposure values will be automatically loaded. For Panoramic exams with child selection, the exposure values and the trajectory length are reduced
- Patient Size: the correct pre-set exposure values will be automatically loaded
- kV/mA selection: the user can manually change the exposure parameters
- HD/XD exam (when available accordingly with the current selection)
- Biting mode (when available accordingly with the current selection)
- Scanning of dental impressions and dental models (only in 3D Mandibular single jaw and if High Definition mode is supported by PC - see paragraph 6.1)



A virtual LED indicates the current status of the unit, while a virtual display shows all service messages related to the current status of the unit and possible error messages.

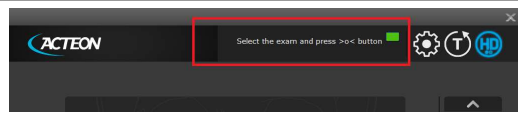

Close to the virtual display there are three different keys that may be selected by the user: Settings (for opening a service menu), Test mode (enable/disable) and HD/XD mode.

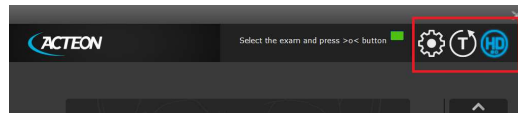

8.5 Digital sensor

The new X-MIND prime 3D is equipped with a CMOS flat panel: suitable for 2D and 3D imaging.

The new X-MIND prime 3D control system checks the consistency of safety measures that allow for correct use of the digital sensor; in particular to prevent acquisition when the image management and processing system is not ready to receive the image, it displays the message "Sensor not ready".

9. MAKING AN EXAM

Note



With paediatric patient it is recommended to have a greater attention in taking exams.

In general with child and adolescent patients, before taking the exposure it is suggested to run the exam in test mode in such a way to show the young patient how the unit works and make them feel comfortable.

To make an exam, proceed as follows:

1. Press the power switch located on the upper part of the equipment on the operator side to position "1". This will start the "CHECK" function, which is indicated by the LEDs lighting up. When the "CHECK" function is complete, the green LED on the equipment keyboard starts blinking.



- Press >O< button on the keyboard to run the equipment axis zero.

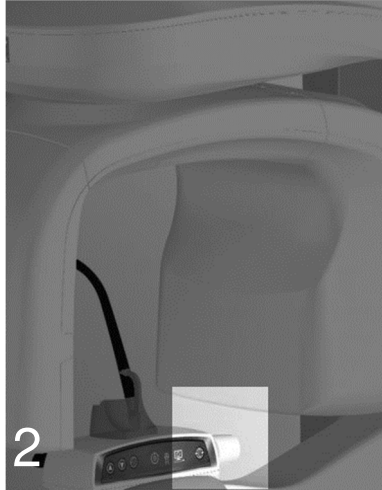

Warning

During equipment axis zero reset, check that the unit does not collide with external object.

- Run the Virtual Interface on the PC and wait for the connection between the PC and equipment; this status is indicated by the blue LED lighting up on the keyboard and on the Virtual Interface.

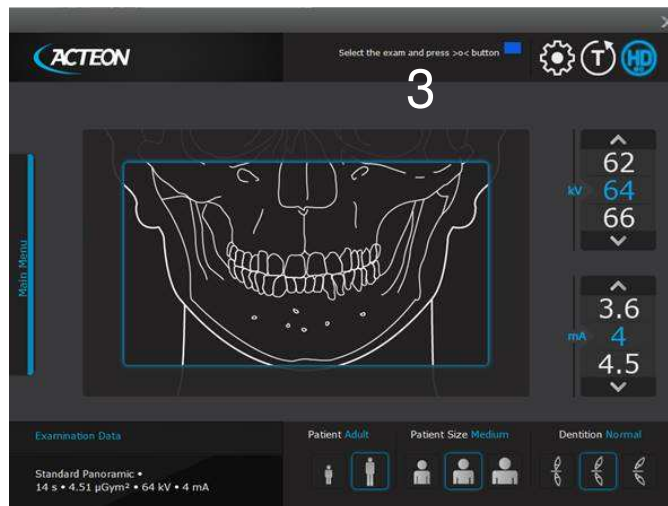

4. Select the exam and parameters on the Virtual Interface.

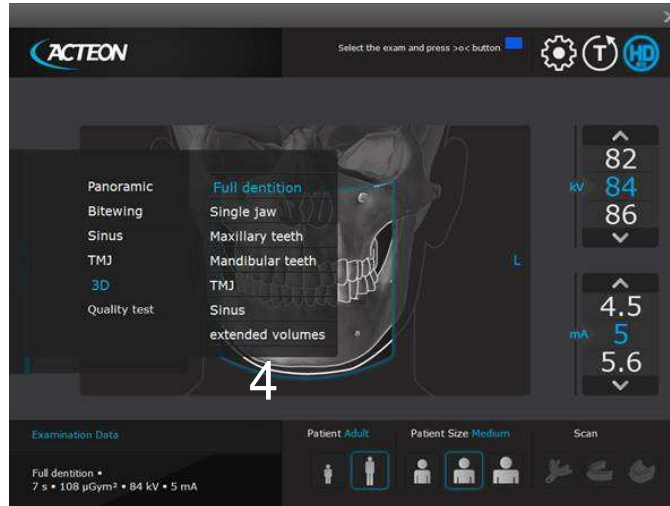

5. Press the button ">O<" on the keyboard to run the chin rest automatic positioning accordingly with the current exam selection.

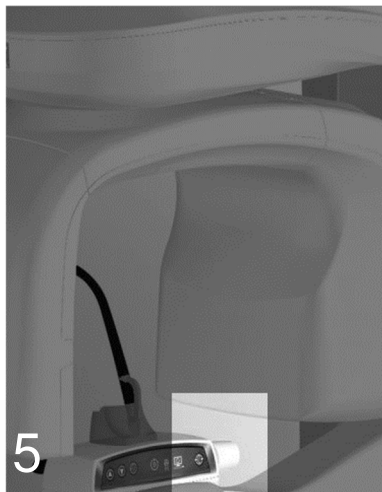

6. The white LED blinks slowly waiting for the chin rest.

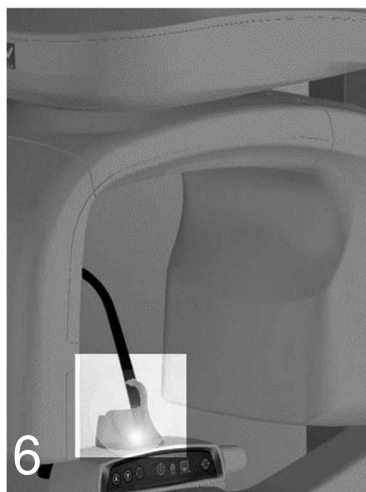

7. Place the proper chin rest (see paragraph 8.2) or the dental model/dental impression support corresponding to the current exam selection.

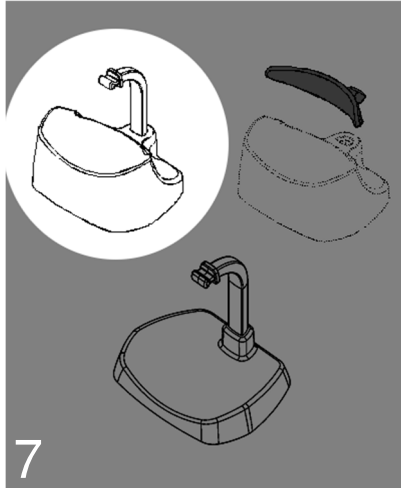

8. If the chin rest or support is correct, the white LED is steady on, otherwise it will blink quickly.

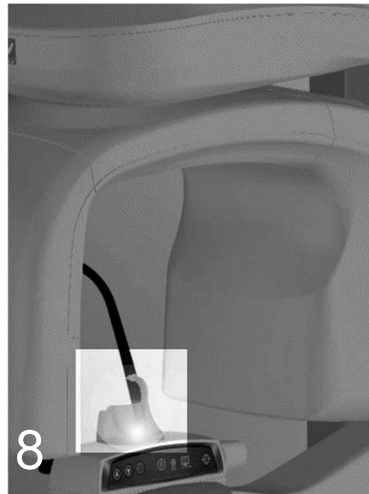
**Note**

To go back in the exam selection status to change exam or settings, the proper chin rest of the current exam has to be placed in position, then press >0< to go in start exam position and then, when green led is ON, press >0< again to go back in exam selection status.

9. Position the patient with the help of the lasers then close the temple clasps.

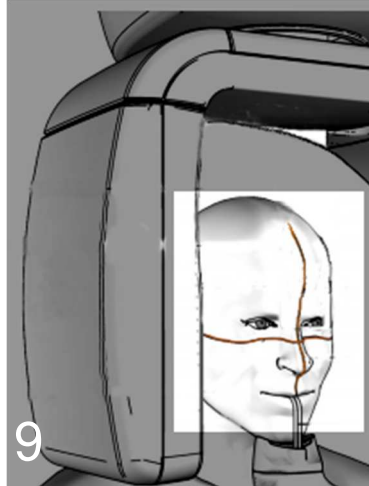

10. Press >O< button to put the equipment in the start exam position; the green LED lights up: the unit is now ready for X-rays.

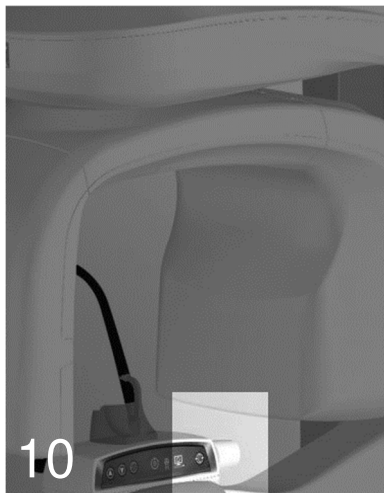

Note

In this state kV and mA can be adjusted, while patient size, patient type and biting can't be changed.



Note

Ready for X-ray status is signalled by the green LED on the equipment (3 - Figure 17) and on the GUI lighting up.
Ready for X-ray status remains as long as the equipment is in the start exam position and the GUI is connected to the equipment.

11. Press the X-ray button for the entire duration of the exposure.



Warning

Since the X-ray button is a "dead man's switch", its release before the end of the exposure, immediately stops the X-ray emission and the arm rotation. Error 362 or Error 760 will be displayed.



Note

The rotation of the arm and the emission of the X-rays will start with a delay of about 3 seconds from when the X-ray button is pressed.



Note

When the "Test" key is selected, the Test function is activated. In this condition, it is possible to make the unit carry out all movements made during the exam without emitting X-rays.

Test mode may also be useful when the equipment is used on child patients, to show them how the equipment works before running the exam.

Once the cycle is completed, deactivate the "Test" function by pressing the key again.

12. Once the exposure is completed, the system will rotate back to patient exit position. It is now possible to free the patient from the positioning device.

13. Press >0< to return to axis 0 position.



Warning

In case of exam interruption, let the patient exit the unit, follow the instruction on the GUI then press >0< to carry out the axis reset.

**Warning**

During the emission of X-rays, protection procedures for the operator and personnel in the area must comply with local regulations. In all cases, it is recommended that only the patient and operator are present in the room during the emission of X-rays. If the operator is not protected by suitable screens, he must stand at least 2 meters away from the emission of the rays (Figure 1).

**Note**

X-MIND prime 3D assumes that the digital sensor is ready: if this is not the case, the blue light indicator of "Computer connection" status (5 - Figure 17) start blinking slowly.

To reset the message on X-MIND prime 3D, press "OK" on the GUI and follow the instruction provided (if on the equipment keyboard the green light indicator of "Machine Ready" status is blinking, press >0< to perform the axis reset).

**Note**

If you try to perform a new exam, before the cooling period has ended, a message indicating the time to wait before performing a new exam will be displayed.

The waiting time allows the anode in the radiogenic tube to cool down.

**Warning**

After each exam, clean the chin support, the handles and the temple clasps group thoroughly and change the disposable bite protective sleeve.

9.1 Anatomic / Manual exposure

**Note**

If the previous exam was carried out manually, press the "Size Selection" key to return to automatic mode.

After setting the equipment, the following two operating modes may be chosen:

- ANATOMIC: with the kV and mA values programmed on the basis of the type of patient and size.
- MANUAL: with the possibility to vary the kV and mA values already set.

**Note**

The exam parameters set as the default are values to be taken as the starting point. Users can optimise the parameters according to their needs.

9.1.1 Anatomic exposure

Select the type of patient with the Adult/Child icons. If child option is selected, exposure parameters are lower respect to the corresponding adult programs. In addition, the exam trajectory in panoramic programs is reduced of about 10%.

Select the type of build with the Size icons (small - medium - large).

On the basis of these selections, the display will show the kV and mA settings accordingly.

Select the type of biting with the icon "Type of Biting Selection" (option available in Panoramic mode only).

Default exposure values in 2D Panoramic modes

	Adult Patient (14 seconds)		Child Patient (12.8 seconds)	
	kV	mA	kV	mA
Small	76	9	66	8
Medium	80	9	68	8
Large	82	9	70	8

Default exposure values in 2D Sinus mode

	Adult Patient (9 seconds)		Child Patient (9 seconds)	
	kV	mA	kV	mA
Small	68	8	64	8
Medium	72	8	66	8
Large	74	8	68	8

Default exposure values in 2D TMJ mode

	Adult Patient (10,6 seconds)		Child Patient (10,6 seconds)	
	kV	mA	kV	mA
Small	70	8	64	8
Medium	74	8	66	8
Large	78	8	68	8

Exposure values in 3D Full Dentition, 3D Extended Volumes and 3D Airways

	Adult Patient (7 seconds)		Child Patient (7 seconds)	
	kV	mA	kV	mA
Small	84	4	64	6.3
Medium	84	5	66	6.3
Large	84	6	68	6.3

**Exposure values in 3D Single Jaw, 3D Maxillary and Mandibular Teeth modes
Normal resolution**

	Adult Patient (7 seconds)		Child Patient (7 seconds)	
	kV	mA	kV	mA
Small	84	4	64	6.3
Medium	84	5	66	6.3
Large	84	6	68	6.3

**Exposure values in 3D Single Jaw, 3D Maxillary and Mandibular Teeth modes
High resolution**

	Adult Patient (7 seconds)		Child Patient (7 seconds)	
	kV	mA	kV	mA
Small	84	8	64	8
Medium	84	10	66	8
Large	84	12.5	68	8

Exposure values in 3D TMJ mode

	Adult Patient (6,2 seconds)		Child Patient (6,2 seconds)	
	kV	mA	kV	mA
Small	82	5	64	6.3
Medium	82	6	66	6.3
Large	82	7	68	6.3

Exposure values in 3D Sinus mode

	Adult Patient (7 seconds)		Child Patient (7 seconds)	
	kV	mA	kV	mA
Small	78	8	64	6.3
Medium	78	9	66	6.3
Large	78	10	68	6.3

**Note**

The exam parameters set as the default are values to be taken as the starting point. Users can optimise the parameters according to their needs.

**Note**

The type of biting does not affect the kV and mA values, but it affects the position of the focus layer, by adapting rotation movement to the patient's anatomy.



9.1.2 Manual exposure

If the pre-set kV and mA pairs are not considered suitable for a specific exam, new parameters can be set in manual mode.

To modify the kV or mA values, press any of the up or down cursors of the KV or mA parameters.

A parameter can be modified by pressing the increase key and the decrease key of the parameter repeatedly.

The kV value can vary between 60 and 86 kV, with 2 kV steps.

The mA value can vary between 2 and 12.5 mA according to the R20 scale.

10. IMAGE PROCESSING WINDOWS

The Image Processing menu, if activated, will be displayed at the end of the acquisition in order to customize the default image post-processing settings. The feature can be either enabled or disabled through the corresponding option available under Settings.

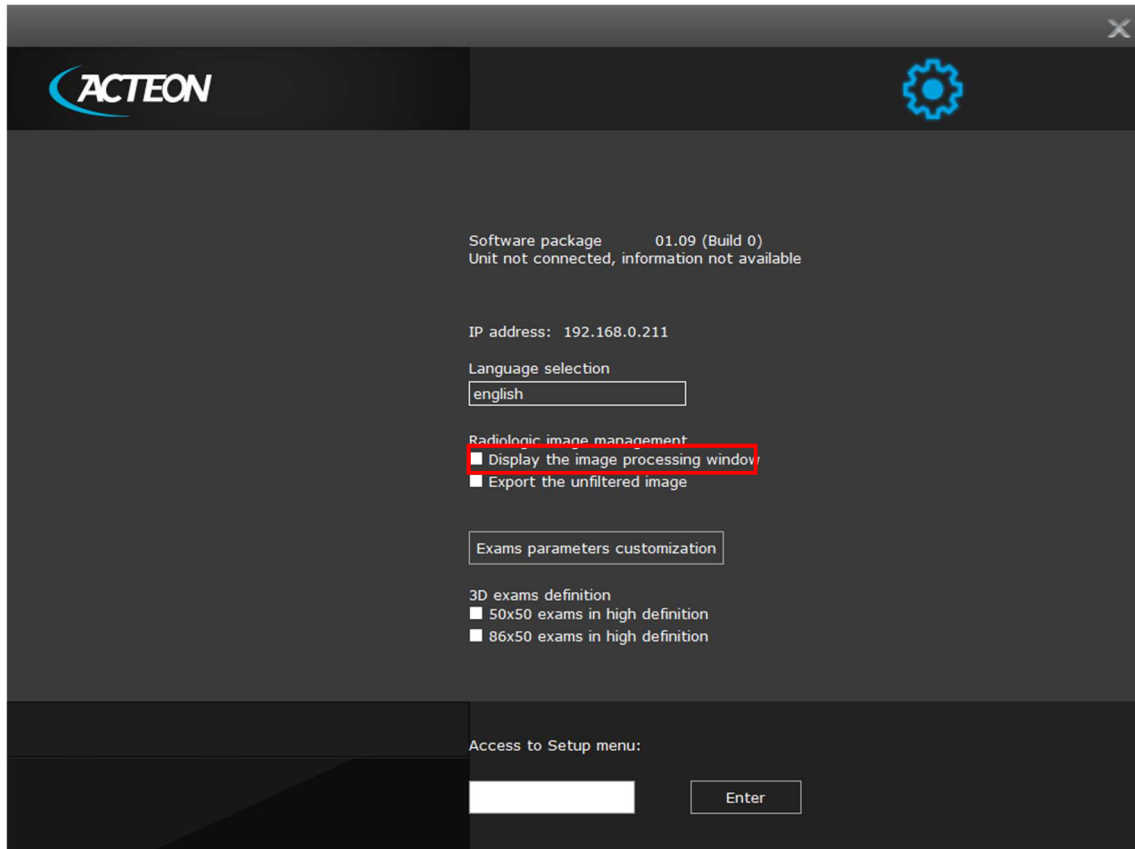

Figure 19

The Image Processing window is composed by three main area (Figure 20):

1. Filters area
2. Toolbars area allowing the filter customization
3. Image preview area displaying the current post-processing.

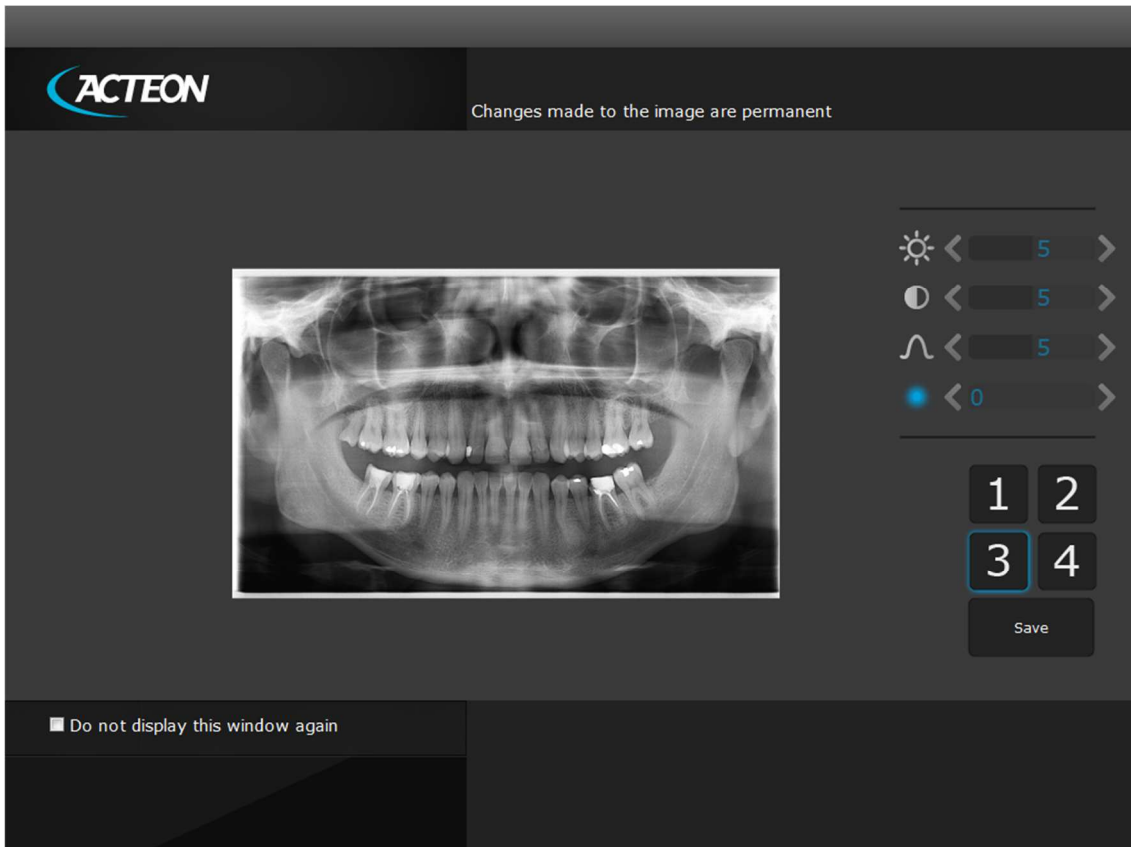

Figure 20

Buttons from 1 to 3 implement pre-set filters. Clicking the button, the corresponding filter will be applied and the preview displayed. The default post-processing can be modified through dedicated toolbars, from the top respectively:

- brightness
- contrast
- gamma value
- image enhancement.

The button Save will apply the current setting to the corresponding button and will set the filter as default in acquisition (Figure 21).
The button 4 is set as default to load the original image (without post-processing) and it can be fully customized as above described.

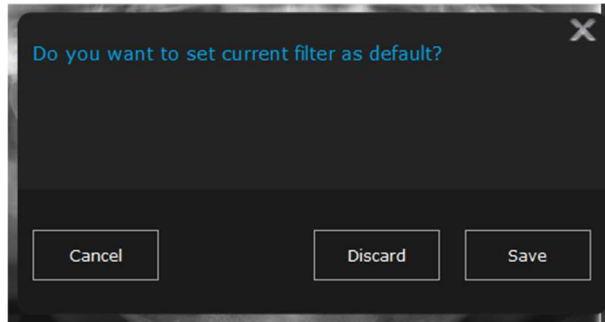

Figure 21

11. 2D EXAMS



Note

The exam parameters set as the default are values to be taken as the starting point. Users can optimise the parameters according to their needs.



Note

The new X-MIND prime 3D is based on a standard dentition and ascending rami shape. This shape, based on statistical studies, establishes a form for the dentomaxillofacial complex, adopted as "standard". X-MIND prime 3D follows a rototranslation path which maintains the magnification factor as stated in the Technical Characteristics of each type of exam as constant along this "standard" shape and in the dentition area. The patient's anatomy can differ significantly from the statistical model, so the magnification factor is not maintained and can be different from the value stated. Based on his experience and competence, the user has to judge this variation.

IN ANY CASE, RADIOGRAPHY IMAGES CANNOT BE USED TO PERFORM CALCULATIONS OF DISTANCES, ANGLES ETC. ON THE IMAGE



Warning

The measurement of lengths on digital images depends on the specific length calibration of the programme used.

It is therefore very important to check the length calibration of the programme. With panoramic exams, to obtain the measurement of the anatomical part, taking into consideration the enlargement factor, the length calibration factor is:

- 100 pixels = 9.4 mm (in the centre of the focus layer) in 2D Panoramic and Sinus.
 - 100 pixels = 9.6 mm (in the centre of the focus layer) in 2D TMJ.
-

**Note**

During panoramic exams, the value of the exposure parameters varies according to a fixed curve, to compensate for variations in absorption by the patient's tissues. In this way, it is possible to obtain a good uniformity of the image contrast. In particular, the chosen value of the kV is lowered in the initial and end sections of the panoramic exam and increased in the incisors/canine zone.

The tube current varies according to the kV, also if the set value is slightly increased on the initial/end sections. These variations have the effect of compensating for greater X-ray absorption in the spinal column area. As an example, the variation of the parameters follows the curve below:

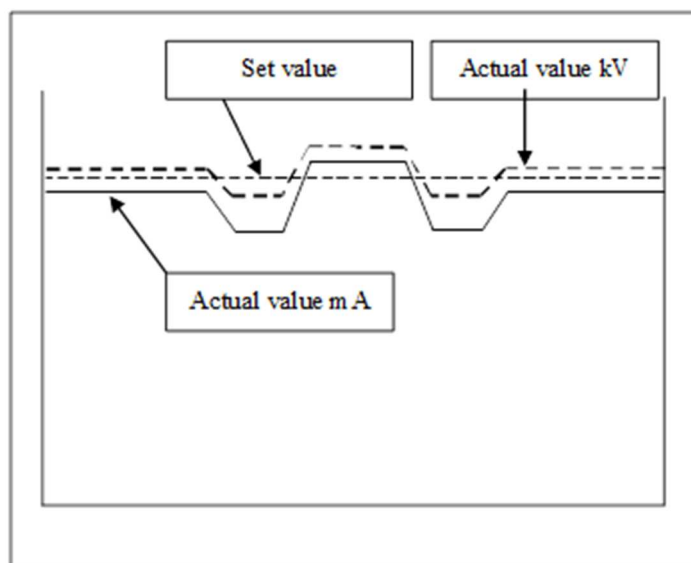

The values displayed during the panoramic exam correspond to the ones chosen by the user, while the real value in the various positions of the X-ray cycle can be different; in any case, the system guarantees that the accuracy of the exposure parameters is always within the limits set by IEC 60601-1 international standards for the safety of medical devices. In particular, in accordance with IEC 60601-2-63, the maximum deviation (including the correction according to the above curve and instrumental doubt) is within $\pm 10\%$ for the kV, while for the tube current it is within $\pm 15\%$.

11.1 Standard Panoramic

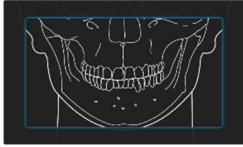

When the unit is switched ON, Panoramic exam mode is selected as standard. If the operator has previously carried out another kind of exam, use the main window in extended view to select Panoramic mode

11.2 Left / Right Half Panoramic

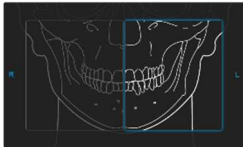

The Half Panoramic mode, right or left, means that only the corresponding half arch is irradiated; emission will start from the beginning, to just after the mid sagittal plane for the right part. For the left, it will start just before the mid sagittal plane and continue until the end of the rotation.

These two kinds of exams are normally used when it is already known that the patient has a problem on only one half of the arch, so it is possible to reduce patient irradiation. Follow the instructions for normal panoramic exams for patient positioning.

11.3 Frontal dentition

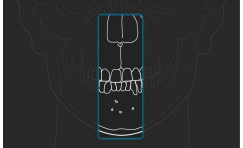

The Frontal dentition exam takes an X-ray of the frontal dentition area (roughly from canine to canine). Follow the instructions for normal panoramic exams for patient positioning.

11.4 Low dose Panoramic



The low dose panoramic exam takes an X-ray only of the dental arch, excluding the ascending rami of the temporo-mandibular joint from the image; the exam is performed with the same trajectory of the standard Panoramic exam, reducing the rays' emission time.

This exam is used, for instance, during treatment continuation phases or where a lack of pathologies of the same joint is already known.

Follow the instructions for normal panoramic exams for patient positioning.

11.5 Ortho Rad dentition



The ortho rad panoramic exam delivers an image of the pure dental arch, excluding the ascending rami branches of the temporo-mandibular joint from the image; the trajectory of the rotating arms is, however, optimised for a better orthogonality between the X-ray beam and incident sections of near teeth. Thus the image has reduced teeth overlapping, improving the diagnosis of interproximal decay.

As a consequence of the different trajectory, the focus layer, mainly in the front teeth area, is smaller and patient positioning for this exam needs more care. Follow the instructions for normal panoramic exams for patient positioning.

11.6 Single Phase Bitewing (L/R)

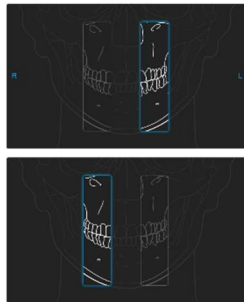

The bitewing mode, right or left, means that only the corresponding bite sector is irradiated; the emission will start from the beginning, to just after the mid sagittal plane for the right part. For the left, it will start just before the mid sagittal plane and continue until the end of the rotation. The exam is performed with the same trajectory of the standard panoramic exam, reducing the rays' emission time.

This exam is normally when it is already known that the patient has a problem on one side of the bite-sectors of the arch, so it is possible to reduce patient irradiation.

Follow the instructions for normal panoramic for patient positioning.

11.7 Bilateral Bitewing



The bilateral Bitewing mode, right and left, means that the two bite-sectors are irradiated; the exam is performed with the same trajectory of the standard panoramic exam, reducing the rays' emission time.

This exam is normally used when it is already known that the patient has a problem on the bite-sectors of the arch, so it is possible to reduce patient irradiation.

Follow the instructions for normal panoramic for patient positioning.



11.8 TMJ O/C



The TMJ Standard function makes it possible to obtain 4 different acquisitions on the same image, by performing two rotational movements. The 4 images represent the right and left condyle of the temporo-mandibular arch (TMJ) with closed mouth and open mouth.

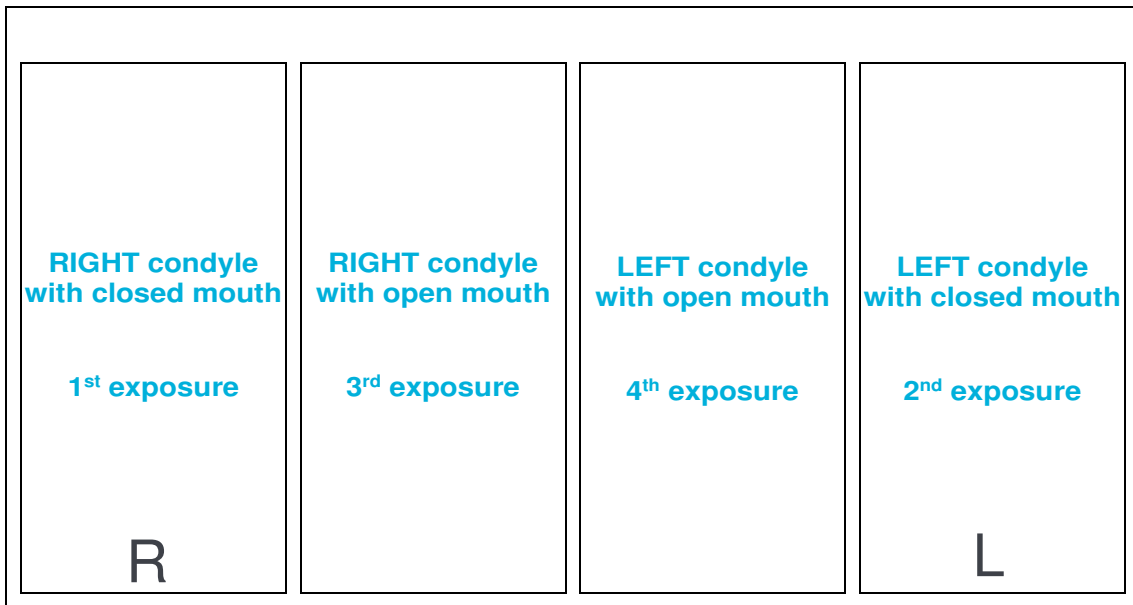
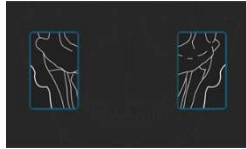

Figure 22: TMJ Open/Closed mouth

11.9 TMJ Single Phase



A single acquisition is made to obtain 2 images representing the right and left condyle of the temporo-mandibular arch (TMJ) with closed mouth or open mouth.

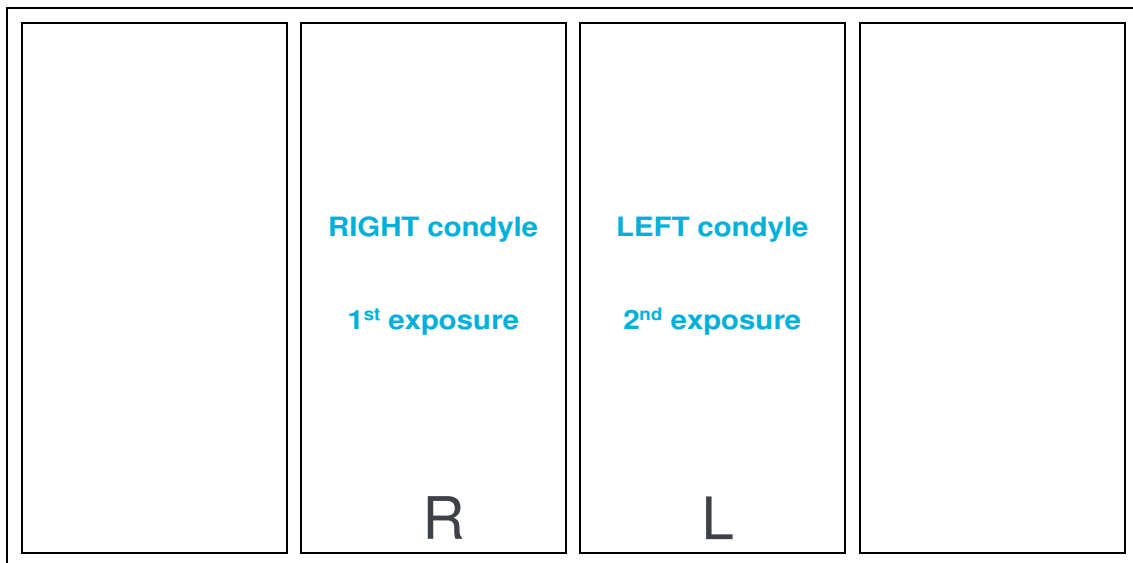

Figure 23: TMJ Single phase

11.10 Sinus



The image is taken on the maxillary sinus area.

12. 3D EXAMS



Note

Especially with pediatric patients evaluate the opportunity to select a smaller Field Of View in order to reduce the dose delivered to the patient.

12.1 Full Dentition

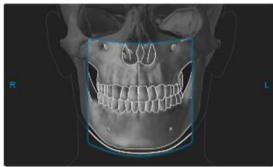

The acquired volume is an 85x93 mm FOV centered to the patient dentition.

In case the collimator kit code 6604061200 is present, the acquired volume will change to 80x80 mm FOV.

12.2 Single Jaw and Dental Impression / Dental model scan

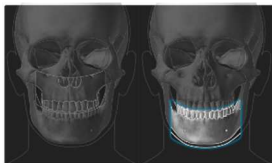

The acquired volume is an 85x50 mm FOV centered either on the maxillary or mandibular arch, depending on the user selection.

In case the collimator kit code 6604061200 is present, the acquired volume will change to 80x50 mm FOV.

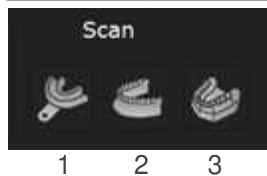

In 3D Mandibular Single Jaw selection, if the eXtra Definition (XD) mode is available (see paragraph 6.1) the following dental impression/dental model scan program are available:

1. Dental impression
2. Cast scan (setting for surgical guide)
3. Plaster model

To perform the scan program, place the support plate on the chin rest and place the dental impression/dental model in the centre of the plate:

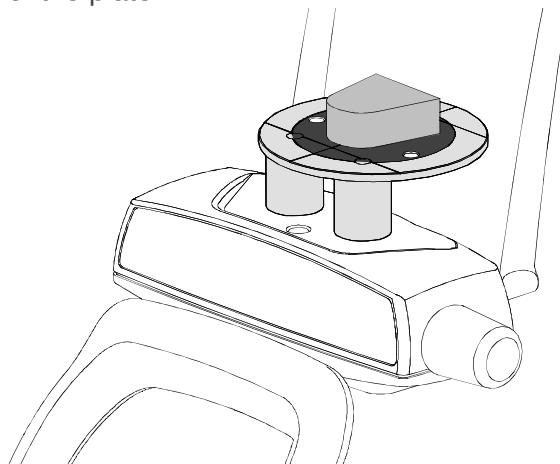
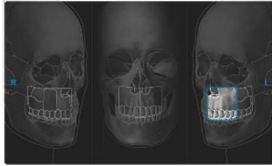

Figure 24

12.3 Maxillary Teeth



The acquired volume is a 50 x 50 mm FOV centered on five different positions along the maxillary arch, depending on the user selection.

12.4 Mandibular Teeth



The acquired volume is a 50 x 50 mm FOV centered on five different positions along the mandibular arch, depending on the user selection.

12.5 Extended Volumes / Airways

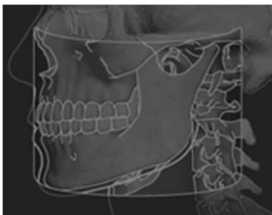

The acquired volume is an 116x103 mm FOV either centered to the patient dentition or back shifted towards the upper respiratory tract.

This functionality is an option and must be activated following the procedure described in the paragraph 8.9 of the Service Manual.

In case the collimator kit code 6604061200 is present, these exams are not available.



Warning

The portion of image volume in the "extended" area is reconstructed using a partial set of projections.

Compared to the central part of the volume, such image portion can have lower definition in the anatomical details.

12.6 TMJ



The acquired volume is an 85x90 mm FOV centered to the temporomandibular joint right or left, accordingly with the user selection.

In case the collimator kit code 6604061200 is present, the acquired volume will change to 80x80 mm FOV.

12.7 SINUS



The acquired volume is an 85x90 mm FOV centered to the maxillary sinus region.

In case the collimator kit code 6604061200 is present, the acquired volume will change to 80x80 mm FOV.

12.8 Metal Artefact Reduction (MAR) filter

A MAR (Metal Artefact Reduction) option can be either activated or deactivated from the Setting page of the GUI. If active, a specific filter for compensating metal artefacts will be applied during the exam reconstruction.

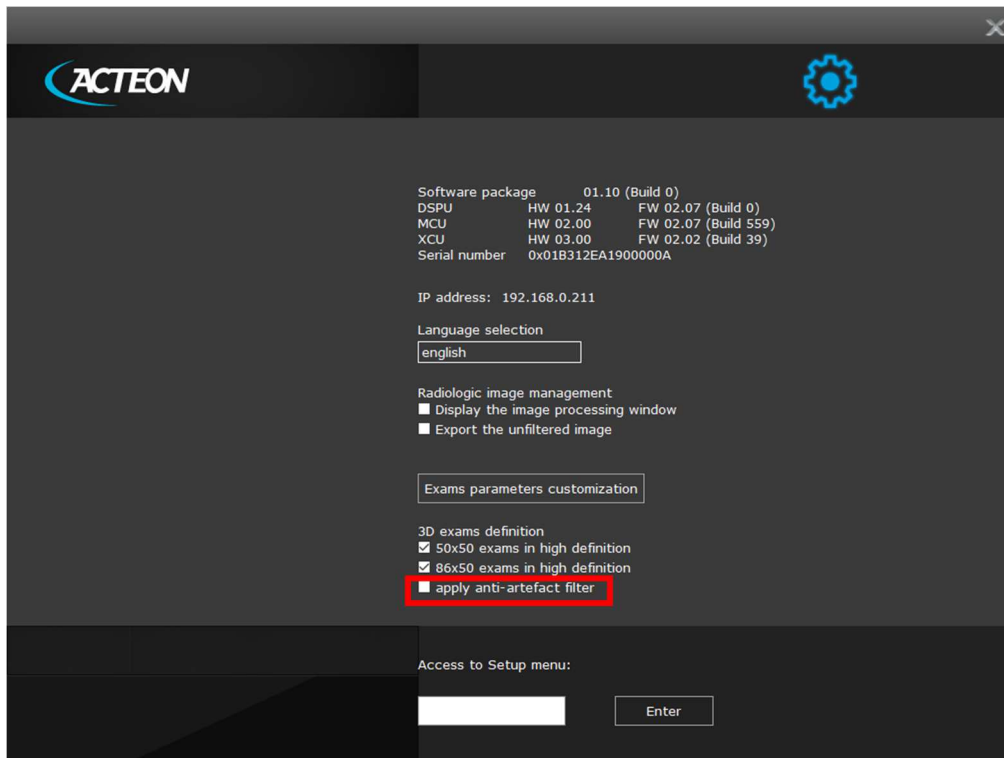
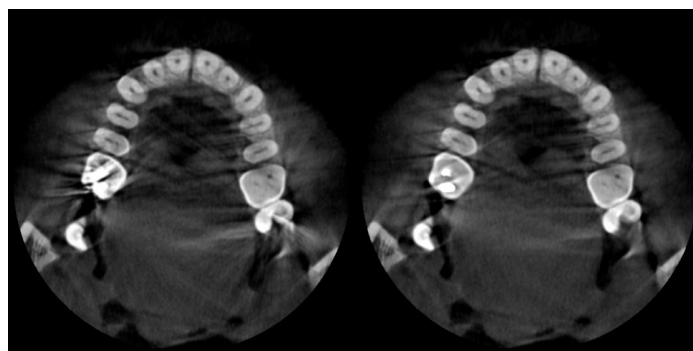

Figure 25

The same filter may be also applied/removed retroactively at any time through the option “new reconstruction” available for exams already archived to the database (see paragraph 12.9).

Note

MAR-processed images should be always compared with the original unprocessed images.



Non-processed image

MAR-processed image

Figure 26

12.9 New reconstruction

To run a new reconstruction of a 3D study, select its icon inside the exam list of the patient folder and right click on it. Then select "New Reconstruction".

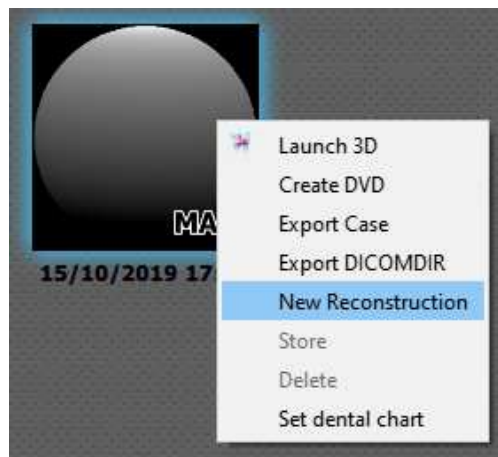

Figure 27

The following window will be displayed:

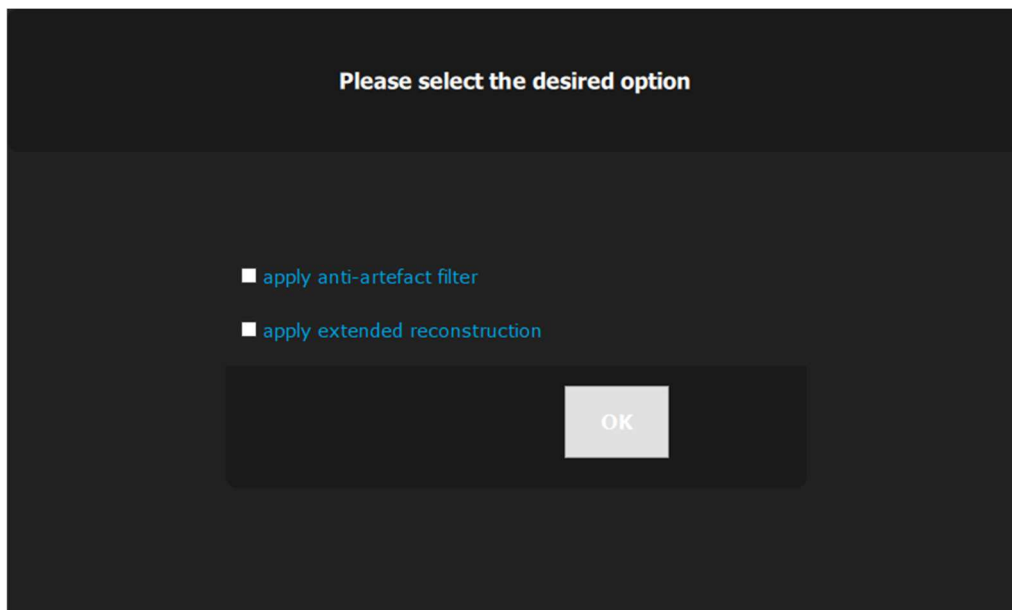

Figure 28



Note

The “apply extended reconstruction” option is enabled only if the Extended Volumes package has been activated on the system.



Note

To launch the “apply extended reconstruction” option, X-MIND prime 3D must be connected to the workstation.

Click on OK button to run a new reconstruction without MAR correction or flag the "apply anti-artefact filter" option and click on OK button to run a new reconstruction with MAR correction.

A 3D study reconstructed with MAR filter (identified with the MAR label), is created in the exam list of the patient folder as shown in figure:



Figure 29



Note

After having run a first reconstruction, if a further reconstruction is launched with one or both options as in Figure 28, the new 3D study will overwrite the previous reconstructed study.

13. PATIENT POSITIONING

13.1 General rules

**Note**

These positioning instructions are valid both for adult and paediatric patients.

**Note**

In general with child and adolescent patients, before taking the exposure it is suggested to run the exam in test mode in such a way to show the young patient how the unit works and make them feel comfortable.

**Note**

If the unit is installed according to suggested height (see paragraph 6.1), the chinrest height when the column is in its lower position is at 97.5 cm (38.4") from the floor, as a consequence, unit can be used with patient at least 118 cm (3 ft 10.4") high.

1. Ask the patient to remove all metallic objects located in the area to be X-rayed (necklaces, earrings, glasses, hairpins, removable dental prosthesis, etc.). Ensure there are no thick garments in the area to be X-rayed (coats, jackets, ties, etc.).
 2. Ask the patient to put on the protective apron, or something similar, making sure it does not interfere with the trajectory of the X-ray beams.
 3. Place the patient in a standing position at the Panoramic chin rest. With the "Column movement" keys (1 - Figure 17), raise/lower the column until the chin support is aligned with the patient's chin.
-

**Warning**

The equipment has a red emergency button located on the upper part of the unit, near the power switch, that only stops the column movement. In case of an emergency column situation, press the emergency button to stop the movement.

**Warning**

During the patient positioning, make sure the equipment cannot collide with any object in the room.

**Note**

If the column doesn't move, check that the emergency button is not pressed. Rotate the button to release it.

4. Position the patient with the temple clasps ensuring that the chin rests on the special support; the hands should rest on the front handles. Ask the patient to bite the reference notch of the bite with his incisors. In the case of edentulous patients, he/she must rest the chin against the reference shoulder of the edentulous chin support.
5. Press the "Luminous centring devices" key (2 - Figure 17). Two laser beams will light up the sagittal medial plane line and the horizontal line. Position the patient's head in such a way as to ensure that the luminous beams fall in correspondence with respective anatomical references (Figure 30).
6. At this point, the patient has to step forward making sure of keeping his head within the pre-aligned anatomical references. This ensures a greater extension of the spine in the cervical area, improving the darkening of the X-ray in the apical area of the incisors, and avoiding the collision of the tube-head with the patient's shoulders.
7. Close the temple clasps to help the patient maintain a correct position.

Note

The laser centring devices remain on for approximately 2 minute; shutdown can be anticipated by pressing the "Luminous centring device" key (2 - Figure 17) or, with alignment complete, by pressing the "Patient entrance" key (6 - Figure 17) to begin preparation for exposure.

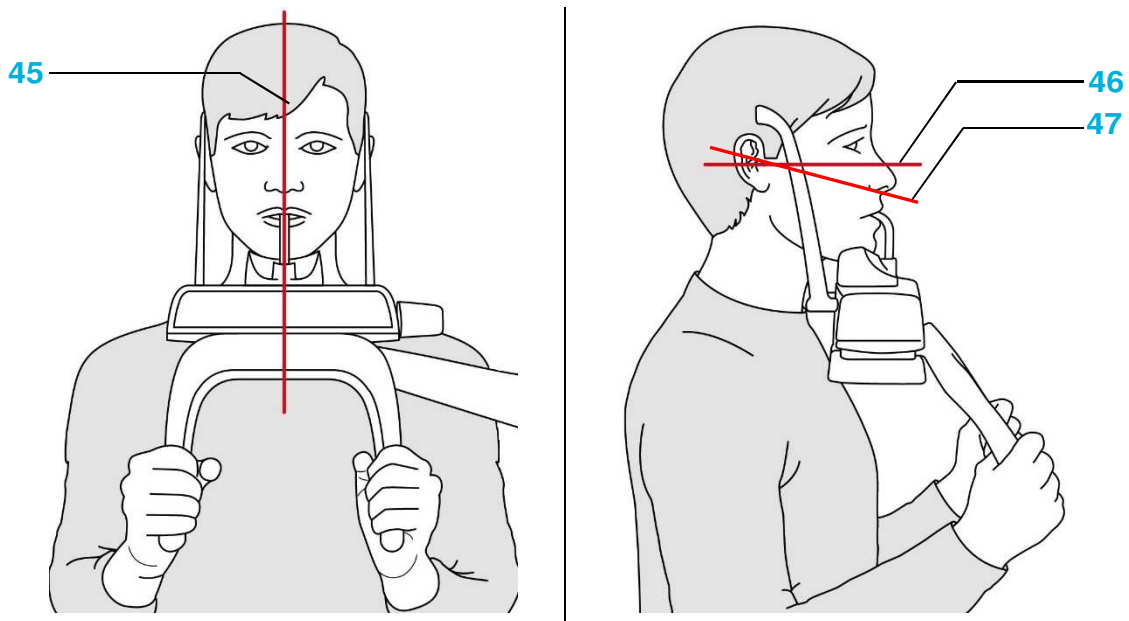

45 - Mid-Sagittal line

46 - Frankfurt plane line: plane that identifies a line that ideally connects the hole in the auricular canal - external auditory meatus - with the bottom edge of the orbital fossa

47 - Ala-tragus line: plane that identifies a line that ideally connects the anterior nasal spine and the centre of the external auditory meatus.

Figure 30: Reference lines

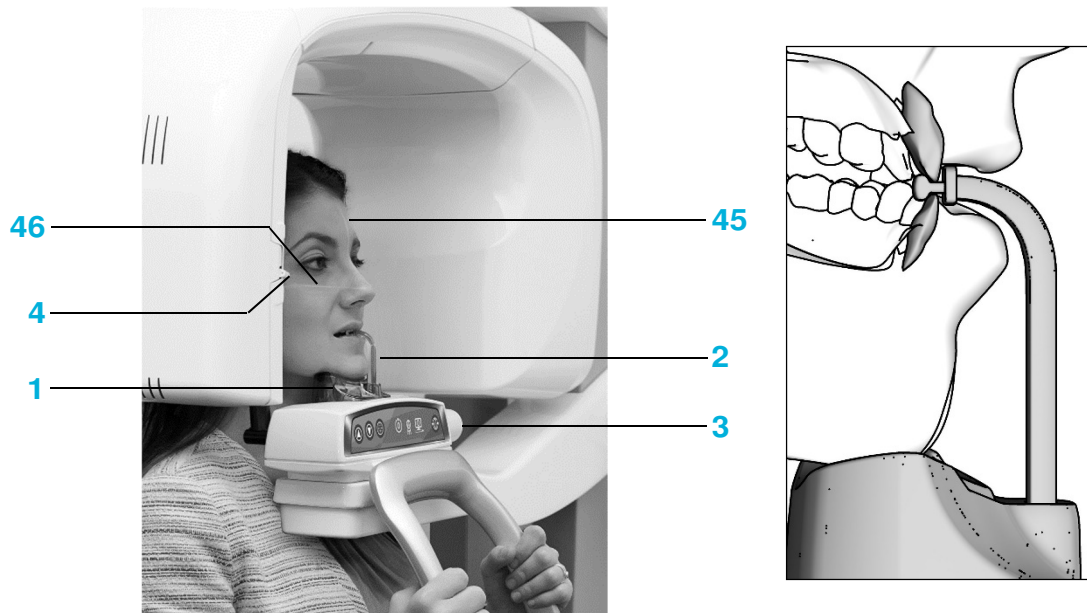

Label	Description	Label	Description
45	Sagittal medial line	2	Centring bite
46	Frankfurt line	3	Temple claps closing/release knob
1	Panoramic chin rest	4	Laser Knob

Figure 31: 2D Panoramic / 3D Full Dentition patient positioning

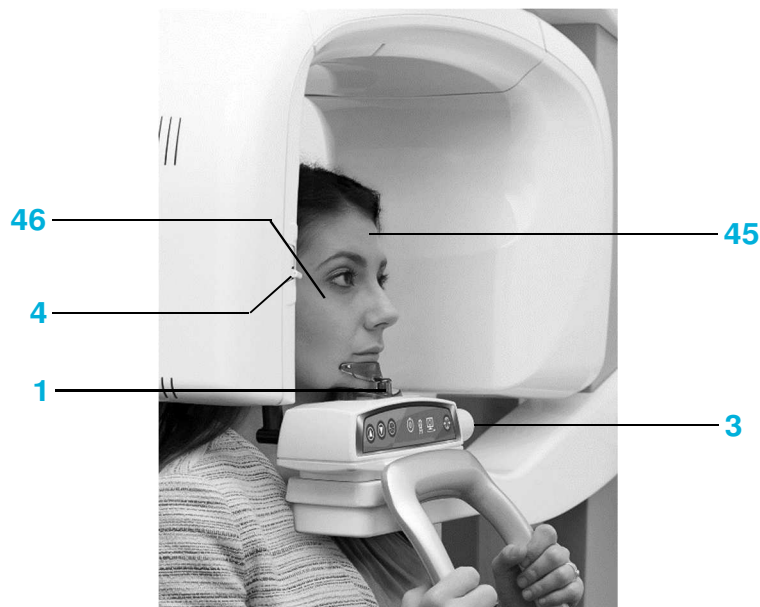

Label	Description	Label	Description
45	Sagittal medial line	3	Temple claps closing/release knob
46	Frankfurt line	4	Laser Knob
1	Tiniest chin rest		

Figure 32: 2D Sinus / 3D Sinus / 3D TMJ / 3D Maxillary patient positioning



Label	Description	Label	Description
45	Sagittal medial line	3	Temple claps closing/release knob
1	TMJ positioner	4	Laser Knob

Figure 33: 2D TMJ open mouth patient positioning



Label	Description	Label	Description
45	Sagittal medial line	3	Temple claps closing/release knob
46	Frankfurt line	4	Laser Knob
1	SINUS chin rest		

Figure 34: 2D TMJ closed mouth patient positioning

13.2 2D exams

- Mid sagittal plane must be centered and vertical.
- Frankfurt plane (the plane that identifies a line that ideally links the ear hole - the auditory meatus - with the lower part of the orbital fossa) must be horizontal.
- Spine should be well stretched.
- In case of use of the bite, patient's incisors must be positioned into the reference notch.
- Patient's tongue must be against the palate.
- Patient must stay motionless during the examination.

13.3 3D exams

- Mid sagittal plane must be centered and vertical.
- Camper plane (ala-tragus plane) must be horizontal.
- Patient's incisors must be positioned into the reference notch of the bite.
- Patient must stay motionless during the examination.

14. ERROR MESSAGES

The error messages are divided into different areas that can be distinguished by the error number; the following table contains the different errors with meanings.

Main MCU board

Code	Error description
000 / 001	Internal MCU error
400 ÷ 411	MCU – DSPU communication fault (CAN Bus)

MCU EEPROM configuration

Code	Error description
100 / 101	Configuration area parameter doesn't match the expected one
102	Wrong version number in configuration area
103 / 104	Timeout error occurred during an EEPROM erase/write operation

Rotation Motor

Code	Error description
200	Zero position optical sensor of rotation axis always activated
201	Zero position optical sensor never activated
202 / 203	Zero position optical sensor of rotation still active after exiting from zero sensor
204	Unexpected activation of rotation optical sensor
205	Timeout on rotation

Y translation motor

Code	Error description
240	Zero position micro Y always active
241	Zero position micro Y never active
243	Timeout on Y axes

Disk collimator

Code	Error description
260	Collimator timeout on zero positioning

Chin rest

Code	Error description
265	Zero position optical sensor always activated
266	Zero position optical sensor never activated
268	Timeout on movement

Hardware key board (U.I.C.)

Code	Error description
270 / 271	Hardware key fault

X-Ray Controls

Code	Error description
360	RX button pressed on start-up or before exam
362	RX button released during emission

Sensor Ready

Code	Error description
370	Sensor ready lost during exposure
371	Sensor not ready

Temperature sensor

Code	Error description
500 ÷ 503	Temperature sensor reading error

Generator Board

Code	Error description
750	Generator board initialization error
751	Alarm "overvoltage kV"
752	Alarm "overload on filament" on Generator board
753	Alarm "overload anodic current"
754	Alarm "filament not OK"
755	Alarm "backup timer"
756	Alarm "PFC not OK"
757	Alarm "Brown OUT"
758	Alarm "NO X-ray"
759	Alarm "unexpected emission"
760	Alarm "NO RX button command"
761	Alarm "NO X-ray emission"
762	Bad unit status: emission flag detected unexpectedly
763	kV analog feedback out of range
764	mA analog feedback out of range
765	Filament analog feedback out of range
766	Generator board reset due to a brown out
767	Generator board reset due to low voltage detection
768	Generator board reset due to a watchdog timeout
769	Generator board reset due to a stack overflow
770	Mismatch between generator board (A2) and MCU board (A1) types (2D / 3D)

Keyboard

Code	Error description
850	One or more keycodes are pressed
852	Button >0< pressed during movements

DSPU

Code	Error description
1003	DSPU hardware error detected
1004	MCU – DSPU communication error
1005	CAN Bus hardware error
1007	Flat panel temperature too high

PC software user interface (GUI)

Code	Error description
1201	Setup menu: write data EEPROM failure
1202	Unexpected value detected by the software
1203	Software allocation failure
1204	Exposure parameters failure
1205	Image buffer allocation failure

PC driver interface (OSP / VSP)

Code	Error description
1401	3D sensor frame lost during exam
1402	3D sensor configuration failure
1403	Software watchdog error
1404	3D sensor do not detect X-rays during exam

15. MAINTENANCE



Note

Maintenance and inspection procedure must be performed without patient positioned in the equipment.

This unit, like all other electrical appliances, must be used correctly and also serviced and controlled at regular intervals. This precaution ensures safe and efficient performance.

Regular maintenance consists of checks performed by the operator and/or by a qualified technician.

The operator can control the following items:

Frequency	Type of check	Method
Daily	Functioning of the indicator lights	Visual inspection
Daily	Check that the cables do not show signs of breaking or wear	Visual inspection
Daily	Check that the unit is not damaged externally in such a way that the safety of protection from radiation is compromised	Visual inspection
Daily	Check that there are no traces of oil on the tube-head	Visual inspection
Daily	Check that arm movement is smooth	Practical inspection
Monthly	Integrity of equipment and labels	Visual inspection
Every 6 Months	QC test	see paragraph 7.5



Warning

If the operator detects irregularities or failures, he must immediately call Technical Service.

Besides the above controls, the Service Engineer will also check the following during preventive maintenance:

Frequency	Type of check
Annually	Correct equipment centring (according to the Service Manual paragraph 9.3.2)
Annually	Check technical factors (according to Service Manual, paragraphs 9.6.8 and 9.6.9)
Annually	Perform sensor calibration
Annually	Check that the fixing screws are tightened

16. PANORAMIC IMAGE ASSESSMENT

Panoramic radiography is an exam of the maxillo-facial region normally used to view the dental region inside the complete head and sinuses-orbital complex.

With a good panoramic exam, you can distinguish the main anatomic structures that are simplified in the diagram below (which indicates only the main ones and is not complete).

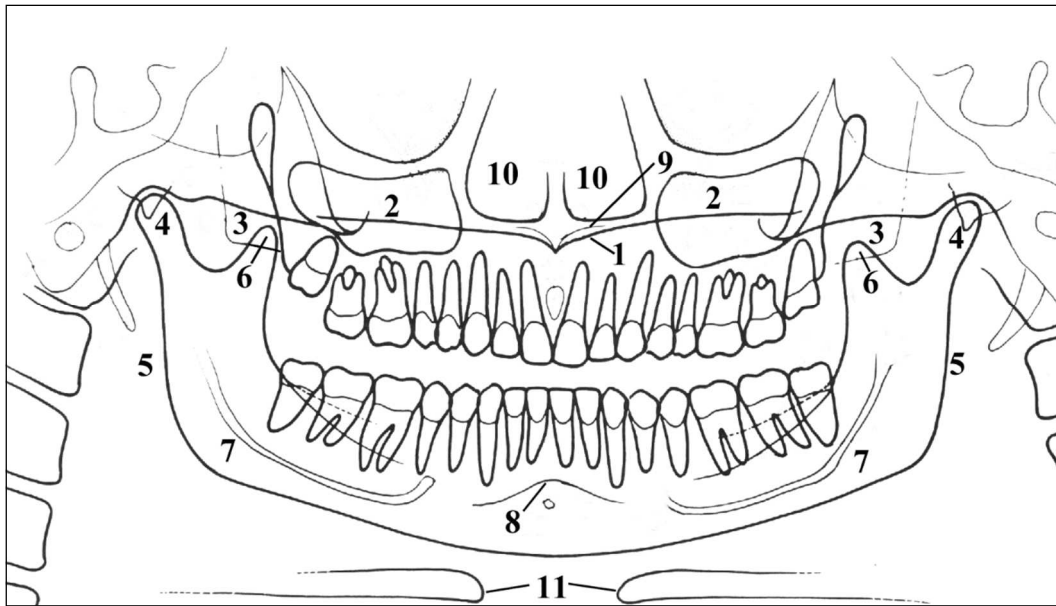

Figure 35

Ref.	Anatomic structure
1	Palatal plane
2	Maxillary sinus
3	Maxilla and maxillary tuberosity
4	Temporo mandibular condyle
5	Ascending ramus of the TMJ
6	Coronoid process (overlap with maxilla)
7	Mandibular canal
8	Chin foramen
9	Anterior nasal spine
10	Nasal cavities
11	Ioid bone (normally duplicated)

16.1 Proper positioning of the patient

Patient positioning is determining to get good quality radiography. This is due to the fact that the shape of the focussed area, e.g. of the layer clearly shown on the image, tends to follow the dental arch and has a non-constant deepness. The objects outside this focused area will therefore appear blurred on the radiography.

1. The patient should not wear clothes that may interfere with the X-ray beams, also to leave more space between the patient's shoulders and the rotating arm of the equipment. Care must be taken in order to avoid interference between the X-ray beam and the protective apron worn by the patient.
2. Metal objects (necklaces, earrings etc.) must be avoided; these objects not only create radio-opaque images in their own position, but also false images projected in other parts of the radiography, so disturbing the correct view of the anatomy.
3. Patient's incisors must be positioned into the reference notch of the bite.
4. Frankfurt plane (plane passing through the inferior margin of the orbit and the upper margin of the ear canal) must be horizontal.
5. Mid-Sagittal plane must be centered and vertical.

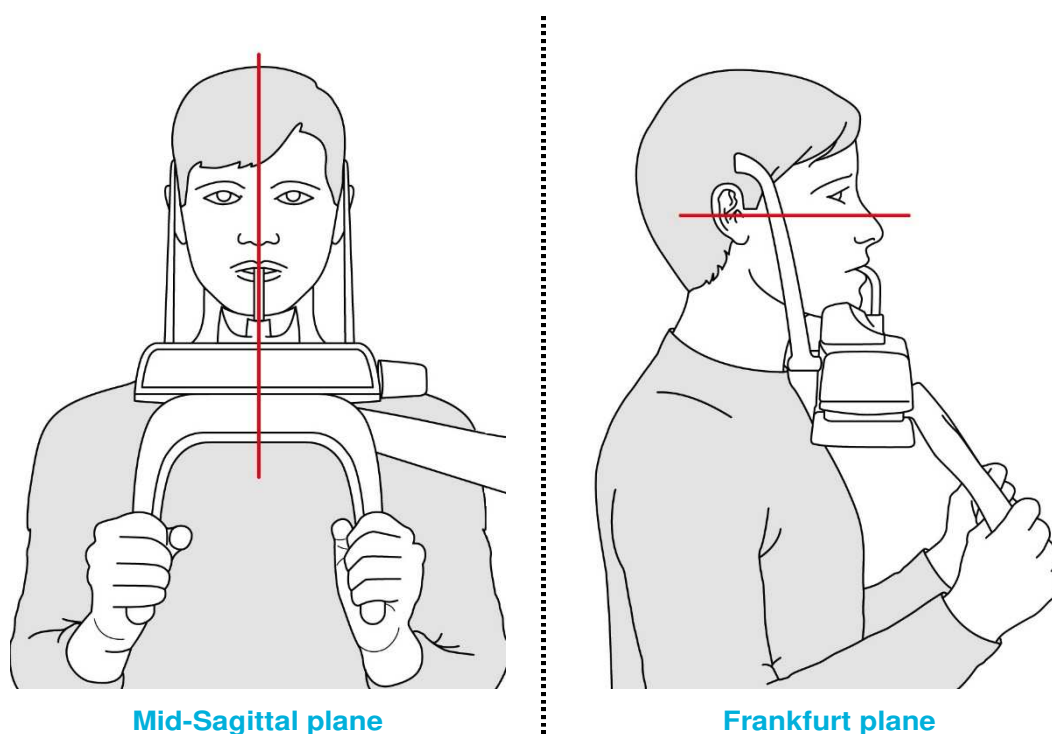

Figure 36

6. Spine should be well stretched, this is normally obtained by asking the patient to step forward, making sure that all other conditions are unchanged. If not properly extended, the spine will cause the appearing of a lower exposed area (clearer) in the front part of the image.

7. Instruct the patient to swallow and keep the tongue against the palate. Patient's tongue must be held closely to the roof of the mouth during the exposure, otherwise a dark air space between the dorsum of the tongue and the palate could obscure the apical region of the maxillary teeth.
8. Patient must stay motionless during the examination.

The result of all the above listed actions will be a radiography where all the parts are properly exposed and are well identifiable as shown in Figure 37.



Figure 37

In a good panoramic image, all anatomic structures are well represented and an equal magnification and sharpness of all structures can be seen.

The image must be symmetric, with the ascending rami of the temporo mandibular joints almost parallel and showing posterior vertical borders. The occlusal plane is quite smiling, despite this the palatal plane does not overlap the apex of the upper arch and therefore allows a good view of the apex itself. The spine is well compensated.



Note

The region of the incisors is the most critical because the anterior portion of the image layer is very narrow. Points 3 and 4 are determining for a good result.



Note

Any flaring of dentition may not allow crowns and apices of both arches to fit in the image layer at the same time. For these patients, you must purposely move him/her further forward in order to move the apices into the image layer.

16.2 Patient positioning errors

16.2.1 Turned head



Figure 38

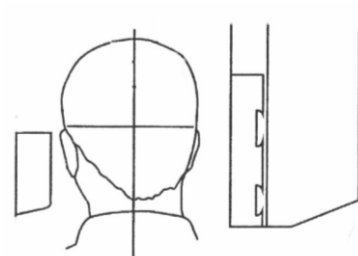

Problem

The patient's head is turned to one side (left or right) in the mid-sagittal plane.

Effects

Condyles are different in size.
The ramous on one side is much wider than the other one.
Asymmetric spine compensation.

16.2.2 Tilted head

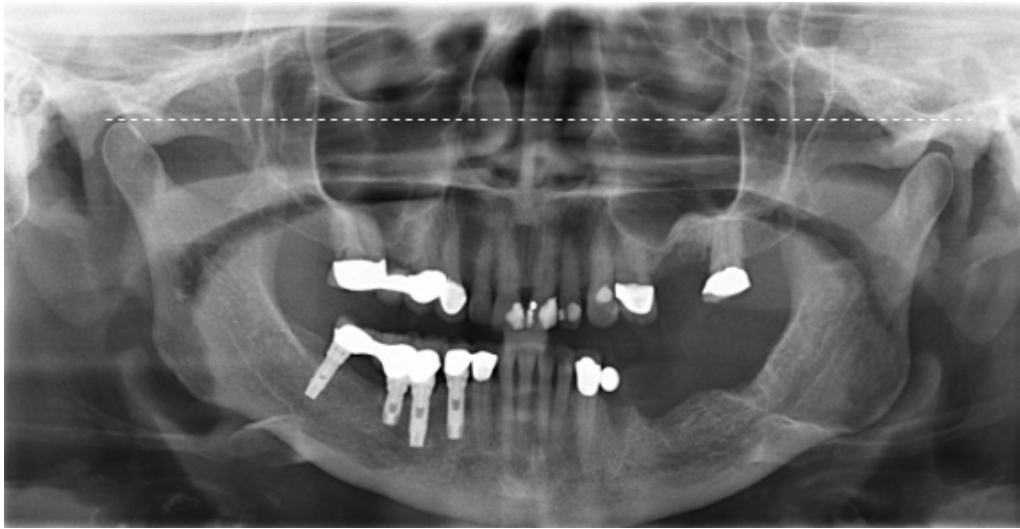
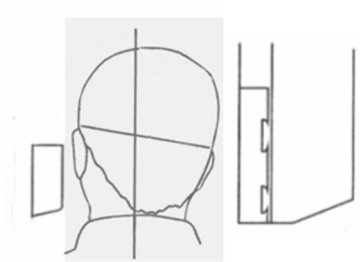

Figure 39



Problem

The patient's head is tilted to one side.

Effects

One condyle appears higher than the other one and the inferior border of the mandible is slanting.

16.2.3 Downward angulation of the head



Figure 40



Problem

The Frankfurt plane is tilted downward.

Effects

The roots of the mandibular anterior teeth are positioned outside the focal trough so it is out-of-focus and blurred (Figure 40 A).

The shadow of the hyoid bone is typically superimposed on the anterior mandible.

Condyles may be cut off at the top of the radiograph.

Pre-molars are severely overlapped.

Severe curvature of the occlusal plane.

16.2.4 Backward angulation of the head



Figure 41



Problem

The Frankfurt plane is tilted backward.

Effects

The roots of the maxillary anterior teeth are positioned outside the focal trough so it is out-of-focus and blurred (Figure 41 A).

The hard palate is superimposed over the apices of the maxillary teeth.

Both condyles may be off the edges of the image area.

The upper incisors can be blurred.

Flattening of the occlusal plane.

16.2.5 Tongue effect

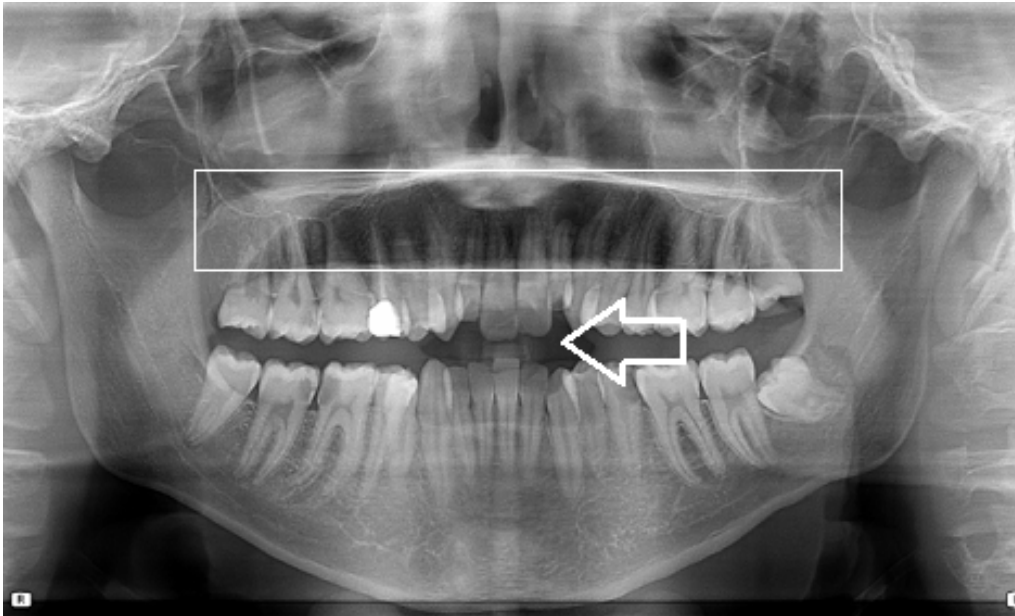
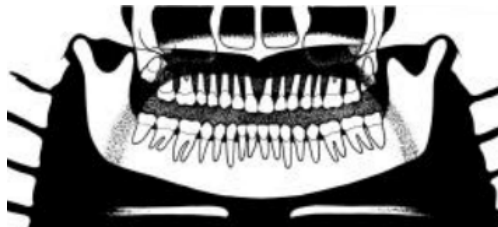

Figure 42



Problem

The patient's tongue was not held closely to the roof of the mouth during the exposure.

Effects

A dark air space between the dorsum of the tongue and the hard and soft palates (palatoglossal air spaces) obscures the apical region of the maxillary teeth.

16.2.6 Spine effect

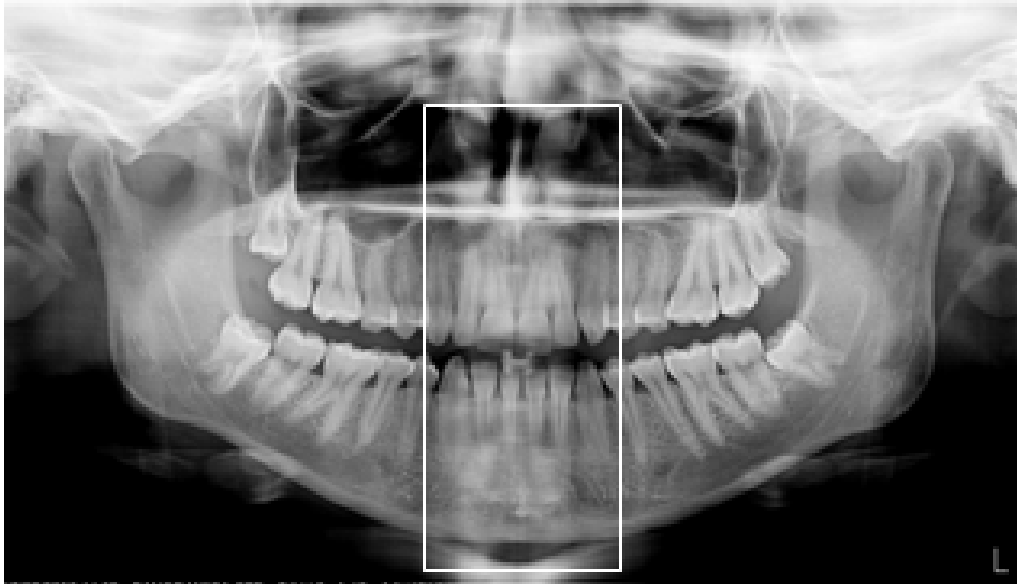
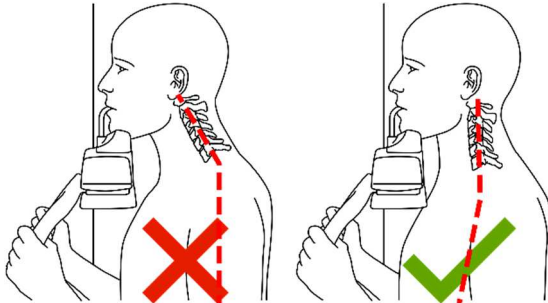

Figure 43



Problem

The patient is slumped.

Effects

The spinal column isn't well stretched causing a ghost image of the spine superimposed in the centre of the image.



MAINTENANCE LOGBOOK

Installation: Date Technician

Maintenance: Date Technician

Cause

Maintenance: Date Technician

Cause

Maintenance: Date Technician

Cause

Maintenance: Date Technician

Cause

Maintenance: Date Technician

Cause

Maintenance: Date Technician

Cause

Maintenance: Date Technician

Cause



THIS PAGE IS INTENTIONALLY LEFT BLANK

CE 0051

de Götzen S.r.l.
Via Roma 45 • 21057 OLGIATE OLONA (VARESE) • ITALY
Tel +39 0331 376 762 • Fax +39 0331 376 763
E-mail: imaging.italysupport@acteongroup.com • www.acteongroup.com

The logo for ACTEON, featuring the word "ACTEON" in a bold, italicized, sans-serif font. A blue swoosh underline is positioned beneath the letters "A", "C", and "T".