

x-mind optima 3D

x-mind optima 3D Operator Manual

Contents

1.	INTRODUCTION	1
1.1	Icons appearing in the manual	1
2.	SPECIFICATION OF THE INTENDED USE	2
2.1	Indications for Use	2
	2.1.1 <i>Intended patient population</i>	2
	2.1.2 <i>Intended operators</i>	3
	2.1.3 <i>Medical condition to be diagnosed</i>	3
	2.1.4 <i>Application environments</i>	3
2.2	Applied parts	3
2.3	Typical doses delivered to the patient during extra-oral exams	4
	2.3.1 <i>Panoramic mode</i>	5
	2.3.2 <i>3D mode</i>	7
	2.3.3 <i>Cephalometric mode (only for the CEPH version)</i>	8
3.	SAFETY INFORMATION	10
3.1	Warnings	11
3.2	Contraindications	12
	3.2.1 <i>Precautions while using laser centring devices</i>	13
3.3	Protection against radiation	14
	3.3.1 <i>Pediatric Use: Summary</i>	16
3.4	Information about Electromagnetic Compatibility	18
	3.4.1 <i>Electromagnetic emissions</i>	19
	3.4.2 <i>Electromagnetic immunity</i>	20
	3.4.3 <i>Proximity fields from RF wireless communications equipment</i>	21
3.5	Cybersecurity measures	22
3.6	Environmental risks and disposal	23
3.7	Symbols used	24
4.	CLEANING AND DISINFECTION	26
5.	DESCRIPTION	28
5.1	Identification labels	28
	5.1.1 <i>Position of identification labels</i>	28
	5.1.2 <i>X-ray source assembly labels</i>	30
	5.1.3 <i>Meaning of information reported on the labels</i>	30
	5.1.4 <i>Warning and caution labels</i>	31

5.2	Functions, models and versions	32
6.	TECHNICAL CHARACTERISTICS	34
6.1	Dimensions	44
6.2	Tube loading curves, anode heating and cooling curves	51
6.3	PC requirements	54
	<i>6.3.1 Characteristics of the supplied workstation (only for XMO 3D with supplied Workstation)</i>	54
	<i>6.3.2 PC suggested characteristics</i>	55
6.4	Software	56
6.5	x-mind optima 3D – PC communication	56
6.6	Reference standard	57
6.7	CBCT Conditions of Operation	59
	<i>6.7.1 Reference Plane</i>	59
6.8	CTDI information	60
	<i>6.8.1 Measure conditions</i>	60
	<i>6.8.2 Measurement procedure</i>	60
	<i>6.8.3 Measured values</i>	61
	<i>6.8.4 Measured Dose values for other conditions of operation</i>	62
	<i>6.8.5 Dose profile</i>	65
7.	REMOVABLE PART LIST	66
8.	QUALITY ASSURANCE PROGRAM	68
8.1	Quality control tools	69
8.2	Functioning of the indicator lights	70
8.3	Laser alignment check	70
8.4	Panoramic and CEPH image quality check	71
	<i>8.4.1 Panoramic image quality check</i>	71
	<i>8.4.2 Cephalometric image quality check (CEPH version only)</i>	74
	<i>8.4.3 Log book</i>	75
8.5	3D image quality check	76
	<i>8.5.1 "QC Tool" software</i>	77
	<i>8.5.2 3D test image acquisition</i>	78
	<i>8.5.3 Nyquist frequency</i>	80
	<i>8.5.4 Contrast to noise ratio</i>	80
	<i>8.5.5 Spatial resolution</i>	81
	<i>8.5.6 CT number</i>	81

8.5.7	<i>Length and width measures</i>	82
8.5.8	<i>Slice thickness</i>	82
8.5.9	<i>Homogeneity</i>	82
8.5.10	<i>Dose at the isocenter</i>	82
8.5.11	<i>Acceptance index</i>	83
8.5.12	<i>Log book</i>	84
8.6	Dosimetry test (paragraph for authorised personnel)	85
8.6.1	<i>Log book</i>	87
9.	GENERAL INSTRUCTIONS FOR USE	88
9.1	Switching the device ON and OFF	88
9.1.1	<i>Switch-on</i>	88
9.1.2	<i>Switch-off</i>	88
9.1.3	<i>Emergency button</i>	89
9.2	Positioning the chin support	90
9.3	Keyboard - Description and functions	94
9.4	Graphical Operator Interface - Description and functions	96
9.4.1	<i>Main GUI area functions</i>	99
9.5	Digital sensor	100
10.	MAKING AN EXAM	101
10.1	Making a panoramic / 3D exam	101
10.2	Making a cephalometric exam (CEPH version only)	104
10.2.1	<i>Making a cephalometric exam from panoramic position</i>	104
10.2.2	<i>Making a new cephalometric exam</i>	106
10.2.3	<i>Going back to panoramic / 3D mode</i>	106
10.3	Pre-set / Manual exposure	107
10.3.1	<i>Pre-set exposure</i>	108
10.3.2	<i>Manual exposure</i>	112
11.	2D IMAGE PROCESSING	113
12.	2D EXAMS	117
12.1	Standard Panoramic	119
12.2	Left / Right Half Panoramic	119
12.3	Frontal dentition	119
12.4	Low dose Panoramic	119
12.5	Ortho Rad dentition	120

12.6	Single Phase Bitewing (L/R)	120
12.7	Bilateral Bitewing	120
12.8	TMJ C/O	121
12.9	TMJ Single Phase	122
12.10	Sinus	122
13.	3D EXAMS	123
13.1	3D Dentition	123
13.2	3D Single Jaw and Dental Impression / Dental model scan	123
13.3	3D Maxillary Teeth	124
13.4	3D Mandibular Teeth	124
13.5	Full Arch / 100x120 airways	124
13.6	Extended Arch	124
13.7	3D TMJ	124
13.8	3D SINUS	125
13.9	Metal Artefact Reduction (MAR) filter	126
13.10	New reconstruction	127
14.	CEPH EXAMS	129
14.1	Latero-Lateral projection	130
14.2	Antero-Posterior projection (symmetric)	130
14.3	Carpus	130
15.	PATIENT POSITIONING IN PANORAMIC	131
15.1	General rules	131
15.2	2D exams	135
15.3	3D exams	135
16.	PATIENT POSITIONING IN CEPH	136
16.1	Bone growth assessment (Carpus)	138
17.	ERROR MESSAGES	139
18.	MAINTENANCE	142
19.	IMAGE ASSESSMENT	144
19.1	Panoramic image assessment	144
19.2	Proper positioning of the patient	145

<u>19.3</u>	<u>Patient positioning errors in panoramic</u>	<u>147</u>
<u>19.3.1</u>	<u><i>Turned head</i></u>	<u>147</u>
<u>19.3.2</u>	<u><i>Tilted head</i></u>	<u>148</u>
<u>19.3.3</u>	<u><i>Downward angulation of the head</i></u>	<u>149</u>
<u>19.3.4</u>	<u><i>Backward angulation of the head</i></u>	<u>150</u>
<u>19.3.5</u>	<u><i>Tongue effect</i></u>	<u>151</u>
<u>19.3.6</u>	<u><i>Spine effect</i></u>	<u>152</u>
<u>19.4</u>	<u>CEPH image assessment (CEPH version only)</u>	<u>153</u>
<u>19.5</u>	<u>Patient positioning errors in CEPH (CEPH version only)</u>	<u>154</u>
<u>19.5.1</u>	<u><i>Tilted Frankfurt plane</i></u>	<u>154</u>
<u>19.5.2</u>	<u><i>Tilted mid-sagittal plane</i></u>	<u>155</u>
<u>EU DECLARATION OF CONFORMITY</u>		<u>158</u>

Note

No part of this publication can be reproduced, transmitted, transcribed or translated without the approval of Acteon.

This manual in English is the original Manual version.

NOTE

[This manual is applicable to x-mind optima 3D with its following configurations:](#)

- **x-mind optima 3D PAN / CBCT version**
- **x-mind optima 3D PAN / CBCT / CEPH version**

Below are reported the REF CODES for which the manual is applicable:

REF CODES	DESCRIPTION
W1203005	XMO 3D WALL 100-240V + WS + MONITOR
W1203010	XMO 3D CEPH 100-240V + WS + MONITOR
W1203005.FL	XMO 3D FLOOR 100-240V + WS + MONITOR
W1203015	XMO 3D WALL 100-240V NO WS NO MONITOR
W1203020	XMO 3D CEPH 100-240V NO WS NO MONITOR
W1203015.FL	XMO 3D FLOOR 100-240V NO WS NO MONITOR

1. INTRODUCTION

Note



This manual is updated for the product it is sold with, to guarantee an adequate reference for using the product properly and safely.
The manual may not reflect changes made to the product that do not affect operating procedures or safety.

x-mind optima 3D, manufactured by de Götzen, is an X-ray device for the radiographic analysis of the maxillo-facial complex.

x-mind optima 3D performs 2D Panoramic, Half-panoramic, Low dose Panoramic, Frontal dentition, Ortho Rad Panoramic, Bitewing Bilateral, Bitewing Left and Bitewing Right, 2D Sinus and 2D TMJ, 3D Dentition with multiple available FOV centered in different areas of the maxillo-facial complex (Dentition, Maxillary Jaw, Mandibular Jaw, Maxillary Teeth, Mandibular Teeth, Full Arch, Extended Arch), 3D Sinus, 3D TMJ, 100x120 airways.

Further to the exams modalities listed above, on its CEPH version, x-mind optima 3D allows to perform the AP and LL cephalometric exams and the Carpus exam.

The aim of this Manual is to instruct the operator on the safe and effective use of the device.

The device must be used complying with the procedures described in this Manual and never be used for purposes other than those indicated herein.

Please read this Manual thoroughly before starting to use the unit; it is advisable to keep the manual close to the device, for reference while operating.

x-mind optima 3D is an electrical medical device and can only be used under the supervision of a physician or of highly qualified personnel, with necessary knowledge of X-ray protection. The operator is liable for legal compliance in relation to the installation and operation of the device.

Warning



The device can be reused only if it is reconditioned under the responsibility of the manufacturer to comply with the general safety and performance requirements

1.1 Icons appearing in the manual



This icon indicates a “NOTE”: please read the items marked by this icon thoroughly.



This icon indicates a “WARNING”: the items marked by this icon refer to safety aspects of the patient and/or operator.

2. SPECIFICATION OF THE INTENDED USE

2.1 Indications for Use

x-mind optima 3D is a digital panoramic, cephalometric and tomographic extra-oral X-ray equipment, indicated for use in:

- producing panoramic X-ray images for diagnostic examination of dentition (teeth), jaws and oral structures;
- producing radiographs of maxillofacial region and parts of the skull for cephalometric examination, if equipped with CEPH arm;
- producing radiographs of hands and wrists for carpus examination, if equipped with CEPH arm;
- producing tomographic images of the oral and maxillofacial region, for diagnostic examination of dentition (teeth), jaws, oral structures and some cranial bones, if equipped with CBCT option.

x-mind optima 3D is not intended to be used in emergency radiology. The device is operated and used by dentists, radiologists and other legally qualified health care professionals, i.e. *Prescription Use (Part 21 CFR 801 Subpart D)*.

The target patient population includes adults and pediatric patients from 7 years old [~27 kg (59.5 lb); 125 cm (49.2 in) standing height].

Anyway, the sustainability to X-ray exposure must be evaluated by surgeons, dentists and qualified and authorized physicians.

Caution

Federal law restricts this device to sale by or on the order of a dentist, a radiologist or another legally qualified health care professional.

2.1.1 Intended patient population

x-mind optima 3D device can be used with the following type of patient:

- Patient population: The target patient population includes adults and paediatric patients from 7 years old [~27 kg (59.5 lb); 125 cm (49.2 in) standing height].

Anyway, the sustainability to X-ray exposure must be evaluated by surgeons, dentists, and qualified and authorized physicians.

- Patient status:
 - self-sufficient patient (the patient can autonomously place himself as requested by the physician)
 - non-self-sufficient patient (the patient is assisted by medical personnel)
 - in any case the patient must be conscious, not anaesthetized and not incapacitated.
- Nationality: multiple.

2.1.2 Intended operators

The device is operated and used by dentists, radiologists, and other legally qualified health care professionals, i.e., *Prescription Use (Part 21 CFR 801 Subpart D)*.

It may only be operated by persons who have suitable experience in radiation protection or knowledge of radiation protection and who have been instructed in the operation of the X-ray equipment.

2.1.3 Medical condition to be diagnosed

From a clinical point of view, the device can be applied for the following medical applications:

- Generic dentistry
- Dental implantology
- Otorinolaringoiatry
- Dental surgery
- Maxillo-facial surgery
- Cephalometric analysis (CEPH version)
- Carpus radiology (CEPH version)

2.1.4 Application environments

x-mind optima 3D may be used in professional buildings (e.g. hospitals, private clinics) or in residential buildings. For the purpose of EMC environment classification both installations are classified as "Professional healthcare facility environment".

Note



In the radiographic room, direct audio and visual communication between operator and patient shall be always possible. If necessary, the operator is responsible to provide a proper arrangement (i.e. lead glass or similar, interphone, etc.).

2.2 Applied parts

During normal use, x-mind optima 3D is in contact with the patient via the handle, chin rest, bite stick, temple clamps, head strips for 3D exams; on its CEPH version, further parts in contact with the patient are the ear rods, the ear centring pins and the nasion reference. All these components are classified as Type B applied parts according to EN 60601-1.

2.3 Typical doses delivered to the patient during extra-oral exams

The estimated dose * area product delivered by x-mind optima 3D to the patient for each exam is indicated in the graphical operator interface.



Note

The dosimetric indications result from the average of dose measures on several X-rays source assemblies.

The dose is taken at a predefined distance from the focal spot of the X-ray source and then reported to the imaging plane.

To get the DAP value, the dose on the imaging plane is multiplied by the X-ray field area measured on the imaging sensor that is 52 cm far away from focal spot for panoramic, TMJ, sinus and 3D exams and 165 cm for the cephalometric exams.

The typical size of the X-ray beam on the imaging sensor depends on the selected exam and on the device version (CEPH or non-CEPH version):

CEPH version:

- for adult 2D except bitewing and cephalometric exams: 140 mm x 4.5 mm
- for child 2D except bitewing and cephalometric exams (*): 120 mm x 4.5 mm
- for adult and child bitewing exam: 109 mm x 4.5 mm
- for cephalometric exam: either 222 x 8.7 mm or 174 x 8.7 mm for the 18 cm high exam

NON-CEPH version:

- for 2D exams: 140 mm x 4.5 mm
- for 3D Dentition, 3D TMJ, 3D Sinus: 150 mm x 124 mm
- for 3D Dentition, 3D TMJ and 3D Sinus (FOV 80 x 80 mm): 123 mm x 109.9 mm
- for 3D Single Jaw (Mandibular and Maxillary): 87 mm x 125 mm
- for 3D Single Jaw (Mandibular and Maxillary) (FOV 80 x 50 mm): 87 mm x 109.9 mm
- for 3D Mandibular and Maxillary Teeth: 84 mm x 77 mm
- for Full Arch and 100x120 airways: 175 x 175 mm
- for Extended Arch: 175 x 175 mm

() this feature is active by default but the operator can disable it and in that case the X-ray beam size is the same as in adult selection*

Except for the cephalometric exams, the distance between the focal spot and the patient skin is variable during the X-ray and on average we can assume the mean distance between the focal spot and the patient skin is 264 mm.

In the cephalometric exams this distance is about 1400 mm.

The overall uncertainty of the indicated value of the air Kerma and dose per area product is 50%.



Note

As stated in EN 60601-2-63, no deterministic effects are known with extra-oral dental X-ray equipment.

2.3.1 Panoramic mode

The air kerma value at the entrance of the X-ray image receptor for the PANORAMIC exam is reported in the table below as functions of kV and mA.

kV	60	62	64	66	68	70	72	74	76	78	80	82	84	86
mA	Air Kerma [mGy]													
2	3.57	3.85	4.14	4.43	4.72	5.00	5.29	5.58	5.86	6.15	6.44	6.61	6.75	6.88
2.2	3.93	4.24	4.56	4.87	5.19	5.50	5.82	6.13	6.45	6.76	7.08	7.27	7.43	7.57
2.5	4.46	4.82	5.18	5.54	5.89	6.25	6.61	6.97	7.33	7.69	8.04	8.26	8.44	8.60
2.8	5.00	5.40	5.80	6.20	6.60	7.00	7.40	7.81	8.21	8.61	9.01	9.25	9.45	9.63
3.2	5.71	6.17	6.63	7.09	7.54	8.00	8.46	8.92	9.38	9.84	10.30	10.57	10.80	11.00
3.6	6.42	6.94	7.45	7.97	8.49	9.00	9.52	10.04	10.55	11.07	11.58	11.89	12.15	12.38
4	7.14	7.71	8.28	8.86	9.43	10.00	10.58	11.15	11.72	12.30	12.87	13.21	13.50	13.76
4.5	8.03	8.67	9.32	9.96	10.61	11.25	11.90	12.54	13.19	13.83	14.48	14.86	15.19	15.48
5	8.92	9.64	10.35	11.07	11.79	12.50	13.22	13.94	14.65	15.37	16.09	16.52	16.88	17.20
5.6	9.99	10.79	11.60	12.40	13.20	14.00	14.81	15.61	16.41	17.22	18.02	18.50	18.90	19.26
6.3	11.24	12.14	13.05	13.95	14.85	15.76	16.66	17.56	18.46	19.37	20.27	20.81	21.27	21.67
7.1	12.67	13.69	14.70	15.72	16.74	17.76	18.77	19.79	20.81	21.83	22.85	23.45	23.97	24.42
8	14.27	15.42	16.57	17.71	18.86	20.01	21.15	22.30	23.45	24.59	25.74	26.43	27.01	27.51
9	16.06	17.35	18.64	19.93	21.22	22.51	23.80	25.09	26.38	27.67	28.96	29.73	30.38	30.95
10	17.84	19.27	20.71	22.14	23.58	25.01	26.44	27.88	29.31	30.74	32.18	33.03	33.76	34.39
11	19.63	21.20	22.78	24.36	25.93	27.51	29.09	30.66	32.24	33.82	35.39	36.34	37.13	37.83
12.5	22.30	24.09	25.89	27.68	29.47	31.26	33.05	34.84	36.64	38.43	40.22	41.29	42.20	42.99

The air Kerma for the other PANORAMIC exams available on the equipment can be calculated using the ratios vs PANORAMIC EXAM in the table below:

Exam	Ratio
Child Panoramic	0.91
Child half panoramic	0.51
Half panoramic	0.55
Child low dose	0.76
Low Dose	0.85
Ortho Rad panoramic	0.90
Frontal dentition	0.33
Bitewing L or R	0.24
Bitewing L and R	0.47
TMJ	0.71
Sinus	0.65

2.3.2 3D mode

The air Kerma value at the entrance of the X-ray image receptor for the 3D exams is reported in the table below as functions of kV and mA.

kV	60	62	64	66	68	70	72	74	76	78	80	82	84	86	88	90
mA	Air Kerma [mGy]															
2	1.37	1.48	1.59	1.70	1.81	1.92	2.03	2.14	2.25	2.36	2.47	2.58	2.70	2.81	2.94	3.06
2.2	1.51	1.63	1.75	1.87	1.99	2.11	2.24	2.36	2.48	2.60	2.72	2.84	2.96	3.09	3.23	3.37
2.5	1.71	1.85	1.99	2.13	2.26	2.40	2.54	2.68	2.82	2.95	3.09	3.23	3.37	3.51	3.67	3.83
2.8	1.92	2.07	2.23	2.38	2.54	2.69	2.84	3.00	3.15	3.31	3.46	3.62	3.77	3.93	4.11	4.29
3.2	2.19	2.37	2.54	2.72	2.90	3.07	3.25	3.43	3.61	3.78	3.96	4.14	4.31	4.49	4.70	4.90
3.6	2.46	2.66	2.86	3.06	3.26	3.46	3.66	3.86	4.06	4.25	4.45	4.65	4.85	5.05	5.28	5.52
4	2.74	2.96	3.18	3.40	3.62	3.84	4.06	4.29	4.51	4.73	4.95	5.17	5.39	5.61	5.87	6.13
4.5	3.08	3.33	3.58	3.83	4.07	4.32	4.57	4.82	5.07	5.32	5.57	5.82	6.06	6.31	6.60	6.90
5	3.42	3.70	3.98	4.25	4.53	4.80	5.08	5.36	5.63	5.91	6.19	6.46	6.74	7.01	7.34	7.66
5.6	3.83	4.14	4.45	4.76	5.07	5.38	5.69	6.00	6.31	6.62	6.93	7.24	7.55	7.86	8.22	8.58
6.3	4.31	4.66	5.01	5.36	5.70	6.05	6.40	6.75	7.10	7.45	7.79	8.14	8.49	8.84	9.25	9.65
7.1	4.86	5.25	5.64	6.04	6.43	6.82	7.21	7.61	8.00	8.39	8.78	9.18	9.57	9.96	10.4 2	10.8 8
8	5.48	5.92	6.36	6.80	7.24	7.69	8.13	8.57	9.01	9.45	9.90	10.3 4	10.7 8	11.2 2	11.7 4	12.2 6
9	6.16	6.66	7.16	7.65	8.15	8.65	9.14	9.64	10.1 4	10.6 4	11.1 3	11.6 3	12.1 3	12.6 3	13.2 1	13.7 9
10	6.84	7.40	7.95	8.50	9.06	9.61	10.1 6	10.7 1	11.2 7	11.8 2	12.3 7	12.9 2	13.4 8	14.0 3	14.6 8	15.3 2
11	7.53	8.14	8.75	9.35	9.96	10.5 7	11.1 8	11.7 8	12.3 9	13.0 0	13.6 1	14.2 2	14.8 2	15.4 3	16.1 4	16.8 6
12.5	8.56	9.25	9.94	10.6 3	11.3 2	12.0 1	12.7 0	13.3 9	14.0 8	14.7 7	15.4 6	16.1 5	16.8 5	17.5 4	18.3 5	19.1 5

The air Kerma for TMJs 3D exams can be calculated using the ratio vs 3D mode in the table below:

Exam	Ratio
TMJ 3D	0.9

2.3.3 Cephalometric mode (only for the CEPH version)

The air kerma value at the entrance of the X-ray image receptor for the 18x24 LL and 18x18 LL High Speed cephalometric exams is reported in the table below as function of kV and mA.

kV	60	62	64	66	68	70	72	74	76	78	80	82	84	86
mA	Air Kerma [mGy]													
2	0.08	0.09	0.10	0.10	0.11	0.12	0.12	0.13	0.14	0.14	0.15	0.16	0.17	0.17
2.2	0.09	0.10	0.11	0.11	0.12	0.13	0.14	0.14	0.15	0.16	0.17	0.18	0.18	0.19
2.5	0.11	0.11	0.12	0.13	0.14	0.15	0.15	0.16	0.17	0.18	0.19	0.20	0.21	0.22
2.8	0.12	0.13	0.14	0.14	0.15	0.16	0.17	0.18	0.19	0.20	0.21	0.22	0.23	0.24
3.2	0.14	0.14	0.16	0.17	0.18	0.19	0.20	0.21	0.22	0.23	0.24	0.26	0.27	0.28
3.6	0.15	0.16	0.17	0.19	0.20	0.21	0.22	0.23	0.25	0.26	0.27	0.29	0.30	0.31
4	0.17	0.18	0.19	0.21	0.22	0.23	0.25	0.26	0.28	0.29	0.30	0.32	0.33	0.35
4.5	0.19	0.20	0.22	0.23	0.25	0.26	0.28	0.29	0.31	0.33	0.34	0.36	0.38	0.39
5	0.21	0.23	0.24	0.26	0.27	0.29	0.31	0.33	0.34	0.36	0.38	0.40	0.42	0.44
5.6	0.24	0.25	0.27	0.29	0.31	0.33	0.35	0.37	0.39	0.41	0.43	0.45	0.47	0.49
6.3	0.27	0.29	0.31	0.33	0.35	0.37	0.39	0.41	0.43	0.46	0.48	0.50	0.53	0.55
7.1	0.30	0.32	0.34	0.37	0.39	0.41	0.44	0.46	0.49	0.51	0.54	0.57	0.59	0.62
8	0.34	0.36	0.39	0.41	0.44	0.47	0.49	0.52	0.55	0.58	0.61	0.64	0.67	0.70
9	0.38	0.41	0.44	0.46	0.49	0.52	0.56	0.59	0.62	0.65	0.68	0.72	0.75	0.79
10	0.42	0.45	0.48	0.52	0.55	0.58	0.62	0.65	0.69	0.72	0.76	0.80	0.84	0.87
11	0.46	0.50	0.53	0.57	0.60	0.64	0.68	0.72	0.76	0.80	0.84	0.88	0.92	0.96
12.5	0.53	0.57	0.61	0.65	0.69	0.73	0.77	0.81	0.86	0.90	0.95	1.00	1.05	1.09

The air kerma for other cephalometric exams available on the equipment can be calculated using the ratios vs the 18x24 LL (or 18x18 LL) High Speed exam in the table below:

Exam	Ratio
24x24 LL and 24x18 LL High Speed	1.35
30x24 LL and 30x18 LL High Speed	1.71
18x24 LL and 18x18 LL High Definition	2.08
24x24 LL and 24x18 LL High Definition	2.82
30x24 LL and 30x18 LL High Definition	3.56
24x24 AP and 24x18 AP High Speed	1.39
24x24 AP and 24x18 AP High Definition	2.88
Carpus	1.04

3. SAFETY INFORMATION

**Warning**

Please read this chapter thoroughly.

The equipment has been designed and manufactured in compliance with safety requirements; furthermore, it supplies all information necessary for correct use, and warnings related to dangers associated with X-ray generating units.

Acteon cannot be held liable for:

- Use of x-mind optima 3D other than its intended use
- Damage to the unit, the operator or the patient, caused both by installation and maintenance procedures other than those described in this Manual and in the Service Manual supplied with the unit, and by erroneous operations
- Mechanical and/or electrical modifications performed during and after the installation, other than those described in the Service Manual.

Installation and any technical operations must only be performed by qualified technicians authorised by Acteon.

Only authorised personnel may remove the covers and/or have access to live components.

**Warning**

In compliance with the EN 60601-1 standard, the modification of the equipment or its parts is strictly prohibited.

3.1 Warnings

The device must be used in compliance with the procedures described and never be used for purposes other than those indicated herein.

Before performing any maintenance operation, disconnect the unit from the power supply.

x-mind optima 3D is an electric medical device and so can only be used under the supervision of suitably qualified medical personnel, with necessary knowledge of X-ray protection.

The operator is responsible for compliance with legal requirements as regards ownership, installation and use of the equipment.

The operator is responsible for a safe set-up and maintenance of the host PC; as a general guidance, cybersecurity suggestions are given in paragraph 0 of this Manual.

The operator is responsible for the execution of the routine quality control procedure described in chapter 8 of this Manual.

This device has not been designed for use in environments where vapours, anaesthetic mixtures flammable with air, or oxygen and nitrous oxide, may be present.

Do not let water, or other liquids, penetrate the device, as this could cause short circuits and corrosion.

Before cleaning the device, make sure the main power supply has been disconnected from the equipment. When pushing the ON/OFF button of the equipment, it must not come on.

Wherever necessary, use appropriate accessories, such as leaded aprons, to protect the patient from radiation.

While performing the X-ray, no-one, apart from the operator and the patient, must remain in the room.

x-mind optima 3D has been built for continuous operation with an intermittent load; so the described use cycles must be observed, to enable the device to cool down.

x-mind optima 3D must be switched off while using electrosurgical devices or similar apparatus.



Warning

For safety reasons, the patient support arm must not be abnormally overloaded, for example by leaning on it. The traction on the handle must be less than 16 kg.



Warning

To avoid the risk of electric shock, the equipment must only be connected to a mains supply with earthing.



Warning

Any serious incident that has occurred in relation to the device should be reported to the manufacturer and the competent authority of the Member State in which the operator and/or patient is established.

Clean and disinfect, when necessary, all parts that may come into contact with the patient.

The centring bite or the bite protective sleeve must be replaced after each exam.

To avoid permanent damage to the unit, never try to rotate the moving arm manually when the unit is switched on.

In the case of Error 362, movement is possible to let the patient exit.

Note

When the unit is switched on, do not move the rotating arm.

Warning for free standing floor mounted unit

In case the unit shall be moved for service or other extraordinary operation, maximum caution shall be taken to prevent the unit from tilting and falling to the ground.

3.2 Contraindications

x-mind optima 3D and x-mind optima 3D CEPH version have been designed to acquire radiography images for dental x-ray and wrist exam (Carpus) imaging only.

x-mind optima 3D and x-mind optima 3D CEPH version medical devices must not be used for x-ray imaging of other body parts except as expressly indicated in intended use!

Caution

Do not carry out tests in the presence of hair clips, metal jewellery, food in the oral cavity (candies, gums), removable orthodontic devices.

Caution

Before exposing patients with pacemakers, contact the manufacturer of the latter to ensure that the x-rays generated by the device do not interfere with its functionality.

Caution

Before using this x-ray device, please refer to the regulation in force concerning paediatric patients, pregnant women and anyone with health issues that contraindicate the use of x-rays.

3.2.1 Precautions while using laser centring devices

For patient positioning, x-mind optima 3D uses two laser diodes with optical power on the working surface < 1 mW.

The directive CEI-EN 60825-1 defines the laser as "any device that produces or amplifies electromagnetic radiation in a coherent manner which includes a wave lengths from 180 nm to 1 mm by means of a stimulated emission". In reference to this directive, the lasers present on the x-mind optima 3D are parts of class 1.

A warning label (See picture below) is affixed to x-mind optima 3D to indicate a laser in class 1 is mounted internally and caution is advised.



Warning

- Always keep the room well lit.
- Do not look into the output windows of laser centring units.
- Do not stare at the reflections of laser pointers.
- Instruct the patient to keep his/her eyes closed as long as the laser pointers are active.
- Before starting an exam, the patient must remove earrings, glasses, necklaces and any other item that could reflect the laser beam or be impressed on the radiographic image.
- Do not clean the openings of laser centring devices with tools that could modify the optics. Any cleaning must only be performed by authorized technicians.
- Operations other than those indicated could cause the emission of dangerous non-ionizing radiation.

3.3 Protection against radiation

Although the dose supplied by dental X-ray units is quite low and distributed on a fairly small surface, the operator must adopt precautions and/or suitable protection for the patient and himself, during radiography.

**Warning**

Protection against radiation is regulated according to law.
The equipment may only be used by specialised personnel.

It is advisable to control the X-ray emission from a protected area, by remote control. If it is necessary to operate near the patient, stay as far as the remote-control cable allows, or at least 2 m both from the X-ray source and from the patient, as shown in the following figure.

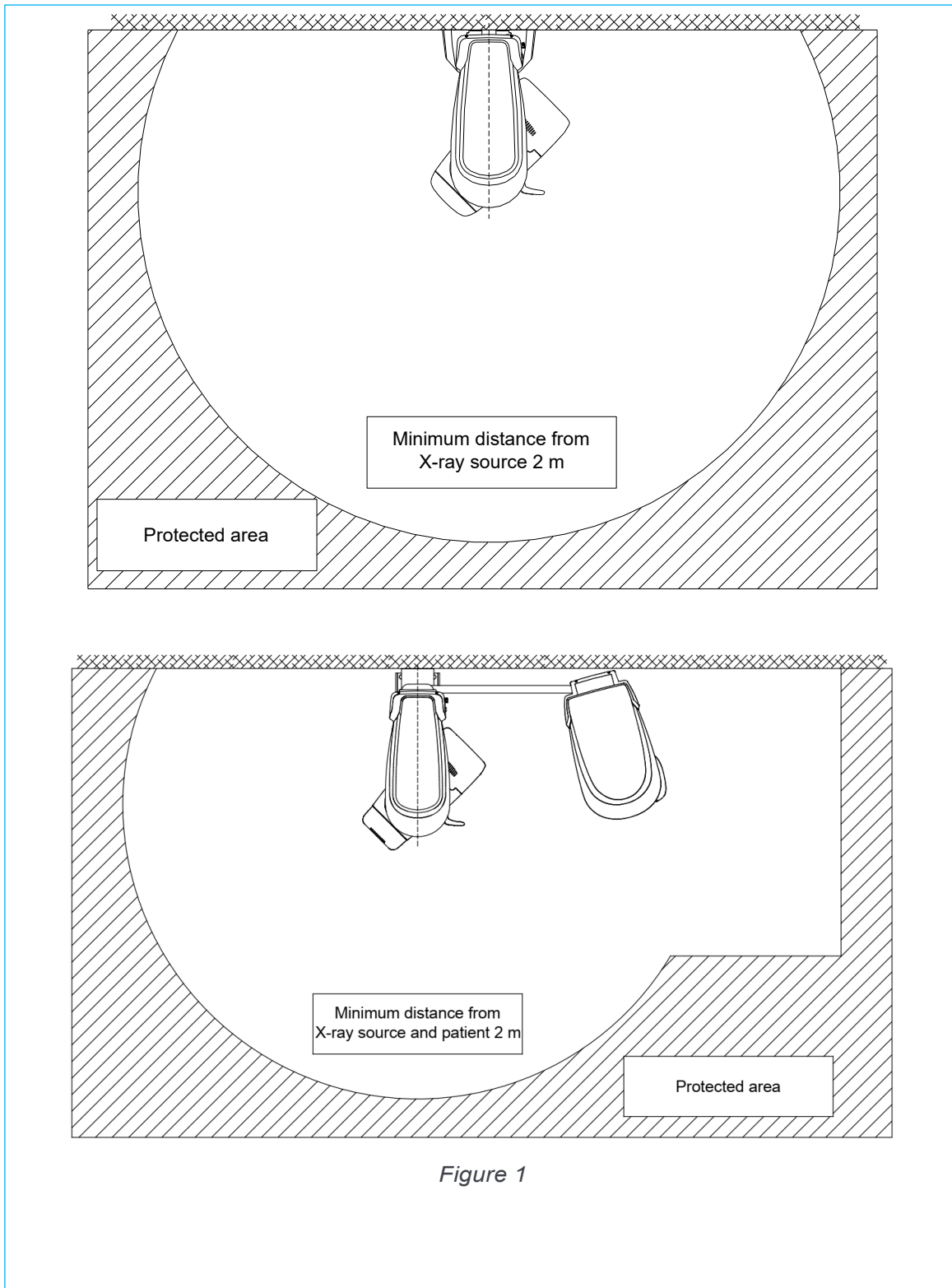

3.3.1 Pediatric Use: Summary

3.3.1.1 Introduction

Special care should be exercised when imaging patients outside the typical adult size range, especially smaller pediatric patients whose size does not overlap the adult size range (e.g., patients less than 50kg (110lb) in weight and 150cm (59") in height, measurements, which approximately correspond to that of an average 12 years old or a 5th percentile U.S. adult female).

3.3.1.2 References for pediatric dose optimization

The following resources provide information about pediatric imaging radiation safety and/or radiation safety for extra-oral dental panoramic and CBCT (aka CBVT) X-ray devices:

1. [HTTPS://WWW.FDA.GOV/RADIATION-EMITTINGPRODUCTS/RADIATIONEMITTINGPRODUCTSANDPROCEDURES/MEDICALIMAGING/UCM298899.HTM](https://www.fda.gov/radiation-emitting-products/radiation-emitting-products-and-procedures/medical-imaging/ucm298899.htm)
2. www.imagegently.org
3. [HTTPS://WWW.FDA.GOV/RADIATION-EMITTINGPRODUCTS/RADIATIONEMITTINGPRODUCTSANDPROCEDURES/MEDICALIMAGING/MEDICALX-RAYS/UCM315011.HTM](https://www.fda.gov/radiation-emitting-products/radiation-emitting-products-and-procedures/medical-imaging/medical-x-rays/ucm315011.htm)
4. <https://www.iaea.org/resources/rpop/resources/training-material#11>
5. [HTTPS://WWW.IAEA.ORG/RESOURCES/RPOP/RESOURCES/TRAINING-MATERIAL#3](https://www.iaea.org/resources/rpop/resources/training-material#3)

3.3.1.3 Device specific features and instructions

x-mind optima 3D provides as standard with all units, the following specific design features and instructions that enable safer use of our device with pediatric patients:

Design features important to pediatric imaging	Paragraph
<p>Adult/Child exam modality: child selection adapts exposure current (mA) and High voltage (kV) reducing the overall dose supplied to the patient.</p> <p>Exposure parameters of 3D exams for a medium-sized child patient give a dose reduction (compared to the adult patient) as recommended by IAEA (see paragraph above, link #4)</p>	9.4 and 10.3.1
<p>For the panoramic exams (panoramic, half-panoramic and low dose panoramic programs) Child selection also corresponds to a reduced trajectory exam time giving a further 10% of dose reduction.</p>	10.3.1
<p>For cephalometric exams, various exam sizes are available both for height and width of the irradiated area.</p>	10.3.1
<p>A function to run the exam in test mode without X-ray to check the behaviour of the patient during the exam and reduce the possibility of exam interruption and retake</p>	9.4 and 10.1
<p>The recommendation – especially with pediatric patients - to use a smaller FOV when taking a 3D exam.</p>	13

3.4 Information about Electromagnetic Compatibility

Medical electrical equipment needs special precautions regarding EMC and needs to be installed and put into service according to the EMC information provided in the accompanying documents.

Portable and mobile RF communications equipment can affect medical electrical equipment.

The equipment can be installed both in professional buildings (e.g. hospitals or clinics) and in residential buildings. Residential buildings, according to EN 60601-1-2 4th edition, are intended to be connected to dedicated power supply equipment (normally fed by separation transformers).

For the purpose of EMC environment classification according to EN 60601-1-2 4th edition, both installations are classified as "Professional healthcare facility environment".

The EMISSIONS characteristics of this equipment make it suitable for use in industrial areas and hospitals (CISPR 11 class A). If it is used in a residential environment (for which CISPR 11 class B is normally required) this equipment, even if it is usually permanently installed in X-Ray shield locations, might not offer adequate protection to radio-frequency communication services. If abnormal performance is observed, such as degradation of essential performance in the form of lack of accuracy of exposure parameters and lack of reproducibility of exposure parameter, additional measures may be necessary, such as re-orienting or relocating the device.



Warning

The use of cables other than:

- Ethernet cable CAT 6 L=5 m
- Ethernet cable CAT 6 L=10 m

with the exception those sold by the manufacturer of the equipment or equipment as replacement parts for internal components, may result in increased emission or decreased immunity of the equipment or equipment.



Warning

x-mind optima 3D should not be used adjacent to or stacked with other equipment; if adjacent use is necessary, x-mind optima 3D has to be observed to verify if it operates in a normal way.

Interference may occur in the vicinity of equipment marked with the symbol



Warning

Portable and mobile RF communications equipment should be used no closer to any part of x-mind optima 3D, including cables. Minimum distance 30 cm.

3.4.1 Electromagnetic emissions

In accordance with the EN 60601-1-2 Ed4 standard, x-mind optima 3D is suitable for use in the electromagnetic environment specified below.

The customer or operator of the equipment must ensure that it is used in the said environment.

Emissions test	Compliance	Electromagnetic environment
RF emissions CISPR 11	Group I	x-mind optima 3D uses RF energy only for its internal function. Therefore, its R.F. emissions are very low and are not likely to cause any interference in nearby electronic equipment.
	Class A	x-mind optima 3D is suitable for use in all establishments other than domestic and those directly connected to the public low voltage power supply network that supplies buildings used for domestic purposes.
Harmonics emissions IEC 61000-3-2	Class A	
Voltage fluctuations/ flicker emissions IEC 61000-3-3	Complies	

3.4.2 Electromagnetic immunity

In accordance with the IEC 60601-1-2 Ed4 standard, x-mind optima 3D is suitable for use in the electromagnetic environment specified below.

The customer or operator of the equipment must ensure that it is used in the said environment.

Immunity test	EN 60601-1-2 test level	Compliance level	Electromagnetic environment
Electrostatic discharge (ESD) IEC 61000-4-2	8 kV contact 2/4/8/15 kV air	EN 60601-1-2 Test level	Floors should be wood, concrete or ceramic tile. If floors are covered with synthetic material, the relative humidity should be at least 30%
Radiated electromagnetic field IEC 61000-4-3	3 V/m 80 MHz to 2.7 GHz	EN 60601-1-2 Test level	Portable and mobile RF communications equipment should be used no closer to any part of x-mind optima 3D including cables. Minimum distance 30 cm
Electrical fast transient/burst IEC 61000-4-4	2 kV for power supply lines 1 kV for input/output lines > 3 m	EN 60601-1-2 Test level	Mains power quality should be that of a typical commercial or hospital environment
Surge IEC 61000-4-5	0.5/1 kV differential mode 0.5/1/2 kV common mode	EN 60601-1-2 Test level	Mains power quality should be that of a typical commercial or hospital environment
Conducted disturbances induced by RF fields IEC 61000-4-6	3 V 150 kHz to 80 MHz 6 V ISM frequencies	EN 60601-1-2 Test level	Portable and mobile RF communications equipment should be used no closer to any part of x-mind optima 3D, including cables. Minimum distance 30 cm
Voltage dips, short interruptions and voltage variations on power supply input lines IEC 61000-4-11	10 ms – 0% a 0°, 45°, 90°, 135°, 180°, 225°, 270°, 315° 20 ms – 0% a 0° 500 ms – 70% a 0° 5 s – 0%	EN 60601-1-2 Test level	Mains power quality should be that of a typical commercial or hospital environment. If the operator of x-mind optima 3D requires continued operation during power mains interruptions, it is recommended that x-mind optima 3D be powered from an uninterruptible power supply or a battery
Power frequency (50/60 Hz) magnetic field IEC 61000-4-8	30 A/m	EN 60601-1-2 Test level	Power frequency magnetic fields should be at levels characteristics of a typical location in a typical commercial or hospital environment

3.4.3 Proximity fields from RF wireless communications equipment

In accordance with the IEC 60601-1-2 + A1 2020 standard, below are reported the estimates of the radiated immunity of electrical and electronic equipment to electromagnetic disturbances coming from RF wireless communications equipment.

Measurements have been made in a fully anechoic chamber and the indicated field strength is pre-calibrated prior to placement of the system under test.

Test n°	Test frequency	Modulation	Frequency range	Test level
1 ¹	385	PM 18 Hz	380 to 390 MHz	27 V/m
2 ¹	450	FM ±5 kHz deviation 1 kHz sine	430 to 470 MHz	28 V/m
3 ¹	710	PM 217 Hz	704 to 787 MHz	9 V/m
	745	PM 217 Hz		9 V/m
	780	PM 217 Hz		9 V/m
4 ¹	810	PM 18 Hz	800 to 960 Hz	28 V/m
	870	PM 18 Hz		28 V/m
	930	PM 18 Hz		28 V/m
5 ¹	1720	PM 217 Hz	1700 to 1990 MHz	28 V/m
	1845	PM 217 Hz		28 V/m
	1970	PM 217 Hz		28 V/m
6 ¹	2450	PM 217 Hz	2400 to 2570 MHz	28 V/m
7 ¹	5240	PM 217 Hz	5100 to 5800 MHz	9 V/m
	5500	PM 217 Hz		9 V/m
	5785	PM 217 Hz		9 V/m

Notes:

¹ Test was performed with antenna in both horizontal and vertical polarization, positioning each EUT face in front of generating antenna. Top and bottom faces are not exposed to EM field for table-top and floor standing equipment

3.5 Cybersecurity measures

Like all computer-based equipment, x-mind optima 3D might be exposed to Cybersecurity threats.

x-mind optima 3D is equipped with hardware provisions that make sure that no unwanted X-ray exposure, laser radiation or motorized movements can be activated even in case of cyber-attack or software failure.

Nevertheless, in order to minimize the possibility of cyber-attacks, it is the operator responsibility to make sure that the following protection measures are followed.

- The initial software installation and equipment set-up shall be done by authorized and trained personnel only and using the software provided with the machine
- Any software or firmware upgrade of the equipment shall be done by authorized and trained personnel only
- After any software or firmware upgrade, or any other maintenance operation, image quality checks shall be performed to ensure the equipment is working as expected. Instructions are given in chapter 8
- Password-protect each operator account on the Windows login. Passwords shall be strong enough (at least made of 8 alphanumeric characters), shall be safely managed by every operator (for example they have not been written down), and should be periodically changed (if the equipment is supplied with a PC, the Windows operator is password-protected, but it is operator responsibility to change the default password and set new ones for all the different operators that will have access to the equipment)
- Activate a screensaver that requires a password to be unblocked after a timeout of 5-10 minute, giving this way an automatic timed method to terminate sessions, preventing an unauthorized access to the computer when it is not used (if the equipment is supplied with a PC, the screen saver is activated by default)
- Install an antivirus software and keep virus definitions up to date
- Activate the windows firewall on the host PC (if the equipment is supplied with a PC, the Windows firewall is activated by default)
- It is recommended to activate a hardware firewall on the WAN router/modem used for internet connection, if present
- Make sure that all other PCs in the network are protected by an anti-virus
- Make a virus scan of USB sticks or CD/DVD media before using them to check that they are free of viruses, malware or any dangerous software
- Avoid installation of an unknown or untrusted software since it may undermine the performance and safety of the computer and the equipment
- Keep the Windows operating equipment up to date by installing all security patches
- Make regular copies (backup) of all your valuable data and store them in a safe place, separately from the host PC

3.6 Environmental risks and disposal

Some parts of the device contain materials and liquids that, at the end of the unit's lifecycle, must be disposed of at appropriate disposal centres.

In particular, the device contains the following materials and/or components:

- Tube-head: dielectric oil, copper, iron, aluminium, glass, tungsten, lead.
- Collimator: lead
- Other parts of the device: non-biodegradable plastic materials, metal materials, printed circuits, iron-plastic materials, lead.



Note

Information for operators of the European Community according to 2012/19/EU Directive on the restriction of the use of certain hazardous substances in electrical and electronic equipment.



The symbol of the crossed waste container on the equipment or packaging shows that the product, at the end of its lifecycle, must be collected separately from other types of waste.

The separate collection of this equipment at the end of its lifecycle is organised and managed by the manufacturer. Operators who need to dispose of this equipment should therefore contact the manufacturer and follow the procedure adopted by the manufacturer for the separate collection of the equipment at the end of its lifecycle.









Proper separate collection for subsequent recycling, treatment and compatible environmental disposal of equipment helps avoid possible negative effects on the environment and on health and encourages the reuse or recycling of materials the equipment is made from.









The CER code for the device is *160213 - Equipment containing different hazardous components (complete radiographs and radiographs only)*

Illegal disposal of the product by the owner of the equipment will result in administrative sanctions, as provided for by applicable regulations.

3.7 Symbols used

In this manual and on x-mind optima 3D itself, apart from the symbols indicated on the keyboard, the following icons are also used:

Symbols	Description
	Device with type B applied parts
	Some parts of the device contain materials and liquids that, at the end of the unit's lifecycle, must be disposed of at appropriate disposal centres
~	A.C. voltage
N	Connection point to the neutral conductor
L	Connection point to the line conductor
	Protection grounding
	Functional grounding
○	OFF; device not connected to the mains
	ON; device connected to the mains
	Laser
	Dangerous voltage
REF	Product identification code
SN	Serial number
MD	Medical Device
UDI	UDI code
#	Model number
	Manufacturing date (year and month)
	Name and address of the manufacturer
Total Filtration	Total Filtration
	Tube-head

Symbols	Description
	Focal spot according to IEC 60336
	Follow instructions for use
	Conformity to the Regulation 745/2017/EU and its revised version and all other applicable Regulations
	Exposure enabled status (the corresponding green LED is on)
	CEPH sensor properly connected
	X-Ray emission (the corresponding yellow LED is on)
	Electronic instructions for use symbol for medical devices, according to EN ISO 15223-1: 2021
	Emergency Button identification

4. CLEANING AND DISINFECTION

In order to guarantee a good level of hygiene and cleaning, it is necessary to carry out the following procedures:



Warning

Disconnect the unit from the mains before performing any cleaning.

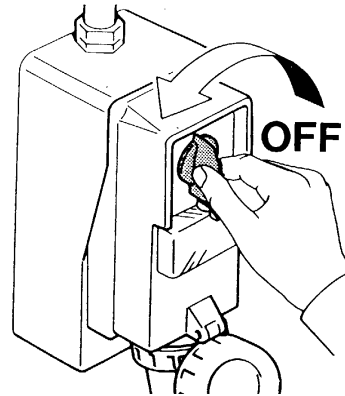

Warning

Do not let water or other liquids penetrate the unit, as these could cause corrosion or short circuits.

The centring bite or the bite protective sleeve must be replaced after each exam. Thoroughly clean the chin support, resting handles and temple clamps group whenever they are used.

The chin support, resting handles and temple clamps group should be disinfected (when considered necessary) with a solution of 2% glutaraldehyde.

For ordinary cleaning, it is recommended to apply a small dose of a mild detergent to clean the painted surfaces, accessories and connection cables and then wipe with a dry cloth.



Warning

Be ensured to clean the whole equipment, not only parts that come in contact with the patient and the operator



Warning

Do not use corrosive, abrasive solvents such as alcohol, benzene or trichloroethylene to avoid degradation of covers.



Warning

Do not apply alcohol on Polycarbonate-based components such as labels to avoid their embrittlement

For extraordinary cleaning use detergents that **DO NOT** contain alkaline solutions, saline solutions, amides, ketones, aromatic hydrocarbons, hexane, trichloroethane, acrylonitrile or dichloromethylene.

Make sure not to apply any oil-based detergent or aggressive detergent and, in any case, do not use a steel sponge, but always soft cloths

Absolutely use zero corrosion cleaners



The centring bite or the bite protective sleeve and the cephalometric ear pin sleeves must be replaced after each exam.

Thoroughly clean the chin support, resting handles, temple clamps, CEPH rods, nasion reference and carpus plate whenever they are used.

The chin support, resting handles temple clamps, CEPH rods, nasion reference and carpus plate should be disinfected (when considered necessary) with a solution of 2% glutaraldehyde.



Note

To ensure a greater level of hygiene the handles of the equipment are covered with a special antibacterial paint which, thanks to the emission of silver ions, reduces the development of micro-organisms.

x-mind optima 3D PAN / CBCT / CEPH configuration labels

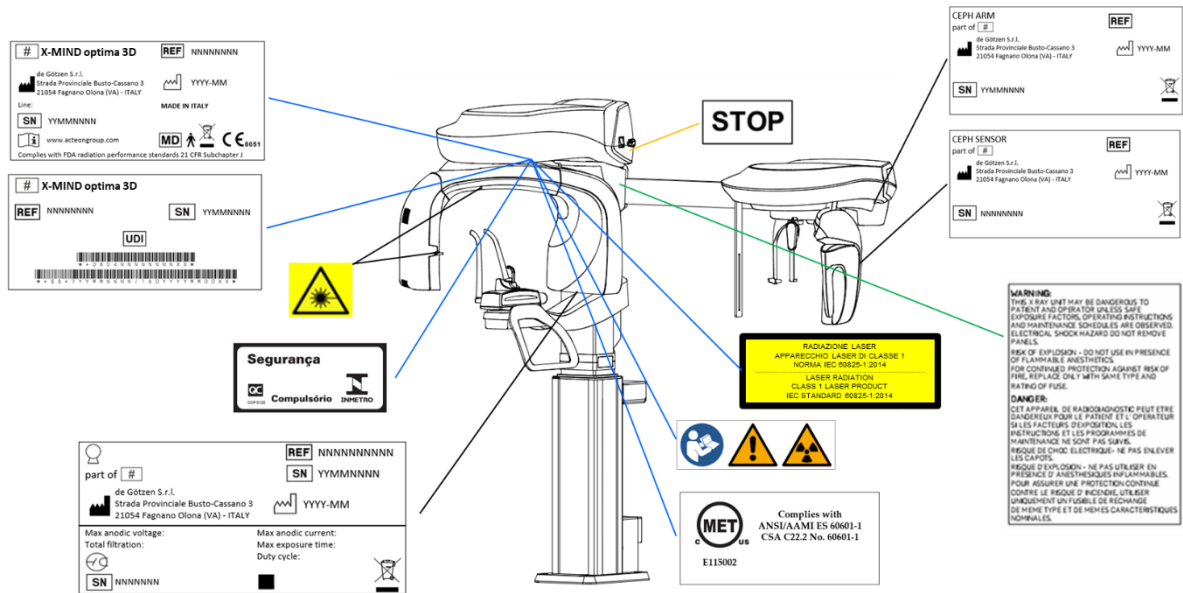

Figure 2: Identification labels

5.1.2 X-ray source assembly labels

Below are reported the monobloc labels concerning the two possible x-ray tubes used.

	PAN / CBCT exams	PAN / CBCT / CEPH exams
MPV03	MPV03 part of # de Götzen S.r.l. Strada Provinciale Busto-Cassano 3 21054 Fagnano Olona (VA) - ITALY YYYY-MM Max anodic voltage: 90 kV Total filtration: ≥ 2.5 mm Al eq. @ 90 kV CEI OX/120-0307 NNNNNNNN Max anodic current: 12.5 mA Max exposure time: 14.4 s Duty cycle: 1/16 0.3 EN 60336 	MPV03 part of # de Götzen S.r.l. Strada Provinciale Busto-Cassano 3 21054 Fagnano Olona (VA) - ITALY YYYY-MM Max anodic voltage: 90 kV Total filtration: ≥ 2.5 mm Al eq. @ 90 kV CEI OX/120-0307 NNNNNNNN Max anodic current: 12.5 mA Max exposure time: 15.1 s Duty cycle: 1/16 0.3 EN 60336
MPV05	MPV05 part of # de Götzen S.r.l. Strada Provinciale Busto-Cassano 3 21054 Fagnano Olona (VA) - ITALY YYYY-MM Max anodic voltage: 90 kV Total filtration: ≥ 2.5 mm Al eq. @ 90 kV CEI OPX/105-12 NNNNNNNN Max anodic current: 12.5 mA Max exposure time: 14.4 s Duty cycle: 1/16 0.5 EN 60336 	MPV05 part of # de Götzen S.r.l. Strada Provinciale Busto-Cassano 3 21054 Fagnano Olona (VA) - ITALY YYYY-MM Max anodic voltage: 90 kV Total filtration: ≥ 2.5 mm Al eq. @ 90 kV CEI OPX/105-12 NNNNNNNN Max anodic current: 12.5 mA Max exposure time: 15.1 s Duty cycle: 1/16 0.5 EN 60336

5.1.3 Meaning of information reported on the labels

Information that cannot be expressed through the use of symbols are written as a text inside the labels.

The translation is provided in the following table:

INFORMATION	TRANSLATION
<i>Line</i>	Line
<i>Max anodic voltage</i>	Max anodic voltage
<i>Max anodic current</i>	Max anodic current
<i>Max exposure time</i>	Max exposure time
<i>Total filtration</i>	Total filtration
<i>Duty cycle</i>	Duty cycle
<i>part of</i>	part of

5.1.4 Warning and caution labels

Laser symbol label



Laser WARNING label



WARNING label

WITH DHHS PERFORMANCE STANDARD 21 CFR SUBCHAPTERJ

WARNING:

THIS X RAY UNIT MAY BE DANGEROUS TO PATIENT AND OPERATOR UNLESS SAFE EXPOSURE FACTORS, OPERATING INSTRUCTIONS AND MAINTENANCE SCHEDULES ARE OBSERVED. ELECTRICAL SHOCK HAZARD - DO NOT REMOVE PANELS. RISK OF EXPLOSION - DO NOT USE IN PRESENCE OF FLAMMABLE ANESTHETICS. FOR CONTINUED PROTECTION AGAINST RISK OF FIRE, REPLACE ONLY WITH SAME TYPE AND RATING OF FUSE

DANGER:

CET APPAREIL DE RADIODIAGNOSTIC PEUT ETRE DANGEREUX POUR LE PATIENT ET L' OPERATEUR SI LES FACTEURS D' EXPOSITION ET LES INSTRUCTIONS NE SONT PAS SUIVIS. ELECTRIQUE CHOC DANGER- NE PAS ENLEVER LES COUVERTURES POUR ASSURER UNE PROTECTION CONTINUE CONTRE LE RISQUE D' INCENDIE. UTILISER UNIQUEMENT UN FUSIBLE DE RECHARGE DE MEME TYPE ET DE MEMES CARACTERISTIQUES NOMINALES

5.2 Functions, models and versions

x-mind optima 3D, manufactured by de Götzen, is a complete dental extraoral X-ray equipment that can perform the following exams:

- Panoramic adult or child exams, with 3 sizes and 3 types of biting for a total of 18 combinations with automatic selection; with manual selection, it is possible to select a high voltage between 60kV and 86kV, in 2kV steps and anodic current from 2 mA to 12.5 mA in the R20 scale steps.
- Sinus mode makes it possible to take exams of the paranasal sinuses with front projection (postero/anterior).
- TMJ closed/open mouth in lateral projection.
- Right or Left Half Panoramic, to be used when the patient is known to have a problem only on one side of the arch, in order to reduce radiation.
- Low dose Panoramic, which reduces the dose radiated by excluding the TMJ's ascending rami from the radiograph.
- Frontal dentition, for a radiograph of the front part (roughly from canine to canine).
- Ortho Rad Panoramic with improved orthogonality, which reduces teeth overlap, thereby improving the diagnosis of interproximal decay.
- Bitewing Left or Right, for lateral dentition (generally from eighth to fourth) with a trajectory that reduces teeth overlap.
- Bilateral Bitewing (Left and Right), which sequentially performs both bitewings, showing them on the same image.
- 3D Dentition (FOV 85 x 93 mm) with 3 sizes for a total of 6 combinations with automatic selection; with manual selection, it is possible to select a high voltage between 60kV and 90kV, in 2kV steps and anodic current from 2 mA to 12.5 mA in the R20 scale steps.
- 3D Single Jaw (FOV 85 x 50 mm) with two different FOV positions (Maxillary, Mandibular), and 3 sizes for a total of 12 combinations with automatic selection; with manual selection, it is possible to select a high voltage between 60kV and 90kV, in 2kV steps and anodic current from 2 mA to 12.5 mA in the R20 scale steps.¹
- 3D Mandibular Teeth (FOV 50 x 50 mm) with five different FOV positions (Frontal, Pre-Molars and Molars), and 3 sizes for a total of 30 combinations with automatic selection; with manual selection, it is possible to select a high voltage between 60kV and 90kV, in 2kV steps and anodic current from 2 mA to 12.5 mA in the R20 scale steps.
- 3D Maxillary Teeth (FOV 50 x 50 mm) with five different FOV positions (Frontal, Pre-Molars and Molars), and 3 sizes for a total of 30 combinations with automatic selection; with manual selection, it is possible to select a high voltage between 60kV and 90 kV, in 2kV steps and anodic current from 2 mA to 12.5 mA in the R20 scale steps.

- 3D TMJ (FOV 85 x 93 mm) with two different FOV positions (R or L), 3 sizes for a total of 12 combinations with automatic selection; with manual selection, it is possible to select a high voltage between 60kV and 90 kV, in 2kV steps and anodic current from 2 mA to 12.5 mA in the R20 scale steps.
- 3D Sinus (FOV 85 x 93 mm) with 3 sizes for a total of 6 combinations with automatic selection; with manual selection, it is possible to select a high voltage between 60kV and 90 kV, in 2kV steps and anodic current from 2 mA to 12.5 mA in the R20 scale steps.
- Full Arch and 100x120 airways (FOV 120 x 104 mm) with 3 sizes for a total of 6 combinations with automatic selection; with manual selection, it is possible to select a high voltage between 60 kV and 90 kV, in 2 kV steps and anodic current from 2 mA to 12.5 mA in the R20 scale steps.
- Extended Arch (FOV 170 x 120 mm) with 3 sizes for a total of 6 combinations with automatic selection; with manual selection, it is possible to select a high voltage between 60 kV and 90 kV, in 2 kV steps and anodic current from 2 mA to 12.5 mA in the R20 scale steps.

With CEPH version

- Cephalometric L-L projections in the formats 18x24, 24x24, 30x24 and 18x18, 24x18, 30x18; the selection between HS High Speed and HD High Definition is available (this projection is available only on x-mind optima 3D CEPH model).
- Cephalometric A-P projections in the format 24x24 and 24x18 the selection between HS High Speed and HD High Definition is available (this projection is available only on x-mind optima 3D CEPH model).
- Carpus Projection in the format 18x24, only in HD High Definition mode (this projection is available only on x-mind optima 3D CEPH model).

Note of cephalometric image formats:

For operator convenience, the CEPH projections are named following the conventional format of the film-cassettes (24 cm), although the vertical active area of the cephalometric sensor is 22.8 cm.

Note



In the case of specific local radioprotection requirements (e.g., in Ontario, Canada, where the Standard of Practice for CT Dental Scanners approved by the Council on April 18, 2011, prescribes specific professional guidelines for the use of CT dental scanners concerning the FOV generated), it is possible to activate the 80x80 FOV limitation setting (i.e. “Unit has 8x8 shield” setting) on the device. When enabled, the 3D Dentition, 3D TMJ, and 3D Sinus FOVs are limited to 80x80 mm and 3D Single Jaw FOV to 80x50 mm and both the Full Arch/100x120 airways and Extended Arch FOVs are NOT available. To activate this setting, refer to the service manual.

6. TECHNICAL CHARACTERISTICS

General features

Type	x-mind optima 3D
Manufacturer	de Götzen S.r.l. 21054 Fagnano Olona (VA) - Italy
Class	Class I with type B applied parts according to EN 60601-1 classification. 
Protection degree	IPX0 standard device
Line voltage	90-264 V
Rated line voltage	100-240 V
Line frequency	50/60 Hz
Maximum line current	16 A @ 100 V 50/60 Hz 6 A @ 240 V 50/60 Hz
Technical factors for maximum line current	90 kV, 12.5 mA
Power consumption	1.6 kVA @ 100 V 50/60 Hz 1.4 kVA @ 240 V 50/60 Hz
Protection fuse (F1)	20 A T 250 V 6.3x32 mm 10 kA @ 125 V 8 A T 250 V 6.3x32 mm 200 A @ 250 V
Column protection fuse (F2) x-mind optima 3D	3 A T 250V 6.3x32 mm 10kA@125V 1.6 A T 250V 6.3x32 mm 100A@250V
Column protection fuse (F2) x-mind optima 3D CEPH version	4 A T 250 V 6.3x32 mm 10 kA @ 125 V 2.5 A T 250 V 6.3x32 mm 100 A @ 250 V
Maximum line apparent resistance	0.2 Ω max (94-110 V) 0.2 Ω max (99-132 V) 0.5 Ω max (198-264 V)
Line voltage regulation	< 3% @ 99 V~
Rated output voltage (kV)	60 – 90 kV, with 2 kV steps
Anodic current	2 – 12.5 mA, with R20 scale steps (2, 2.2, 2.5, 2.8, 3.2, 3.6, 4, 4.5, 5, 5.6, 6.3, 7.1, 8, 9, 10, 11, 12.5)
Total filtration	≥ 2,5 mm Al eq. @ 90 kV ref. EN 60601-1-3

Exposure times

Panoramic exam (PAN)	14 s Adult / 12.8 s Child
Half panoramic exam	7.7 s Adult / 7.1 s Child
Ortho Rad panoramic exam	11.5 s Adult / Child
Low dose panoramic exam	11.6 s Adult / 10.4 s Child
Frontal dentition	4.1 s Adult / Child
Bitewing Right, Bitewing Left	3.1 s Adult / Child
Bitewing Right & Left	6.2 s Adult / Child
TMJ mouth closed/open	10.6 s for left and right joint in open and closed condition
TMJ single phase	5.3 s
Sinus P/A projection	9 s
3D exams (except TMJ 3D)	5.3 s
TMJ 3D	4.7 s
Latero lateral 18x24 and 18x18 cephalometric exam (CEPH version only)	9.1 s HD / 4.4 s HS
Latero lateral 24x24 and 24x18 cephalometric exam (CEPH version only)	12.1 s HD / 5.8 s HS
Latero lateral 30x24 and 30x18 cephalometric exam (CEPH version only)	15.1 s HD / 7.3 s HS
Antero posterior 24x24 and 24x18 cephalometric exam (CEPH version only)	12.1 s HD / 5.8 s HS
Carpus (CEPH version only)	4.4 s
Carpus HD (CEPH version only)	9.1 s
Exposure time accuracy	± 5 % or ± 20ms whichever is greater

Note

For the exams that consist of two or more irradiation period the indicated irradiation time is the sum of the irradiation time of all the periods.

- **Irradiation time in Bitewing R, L and TMJ mode**

During Bitewing Bilateral and TMJ exams x-rays are turned on and off 2 or 4 times. The total exposure time is calculated by the sum of the time in which x-rays are active considering the modulation pattern of the irradiation.



- ***Bilateral Bitewing*** is made by 2 irradiation periods each of them 3.1 s long - the total exposure time of the exam is 6.2 s
- ***Single Phase TMJ*** is made by 2 irradiation periods each of them 2.65 s long – the total exposure time of the exam is 5.3 s
- ***Standard TMJ*** is made by 2 different phases each of them made by 2 irradiation periods 2.65 s long – the total exposure time of the exam is 10.6 s

- **Irradiation time in 3D CBCT**

In 3D CBCT exams x-ray emission is in pulsed mode. The total exposure time is the irradiation time of a single x-ray pulse multiplied by the number of x-ray pulses of the exam:

- **TMJ 3D exams** is made by 364 irradiation pulses each pulse is 0.013 s long - the total exposure time of the exam is 4.7 s
- **High Definition Small FOVs exams** are made either by 408 irradiation pulses each pulse is 0.013 s long - the total exposure time of the exam is either 5.3 s or 4.7 s
- **All the other FOVs exams** are made of 408 irradiation pulses each pulse is 0.013 s long - the total exposure time of the exam is 5.3 s.

Exam modes

Exam selection	<ul style="list-style-type: none"> • Automatic selection for Adult and Child, 3 Sizes • 3 biting modes (Panoramic exam) • Manual selection
Panoramic exam	<ul style="list-style-type: none"> • Standard panoramic • Half panoramic Left/Right • Ortho Rad panoramic • Low dose panoramic • Frontal dentition • Bitewing Left/Right • Bitewing Left and Right
TMJ (Temporal Mandibular Joint) exam	TMJ closed and open mouth
Sinus	Sinus P/A projection
Volumetric 3D exams	Automatic selection for Adult and Child, 3 sizes chosen between: 3D Dentition, 3D Single Jaw (Mandibular/Maxillary), 3D Mandibular/Maxillary Teeth (frontal, premolar, molar), 3D TMJ (Left/Right), 3D Sinus

3D Dentition reconstructed volume

3D Dentition (*)	85 mm x 93 mm (Diameter x Height)
3D Single Jaw (Mandibular and Maxillary) (*)	85 mm x 50 mm (Diameter x Height)
3D Mandibular/Maxillary Teeth	50 mm x 50 mm (Diameter x Height)
Full Arch (*)	120 mm x 104 mm (Diameter x Height)
100x120 airways (*)	120 mm x 104 mm (Diameter x Height)
Extended Arch (*)(**)	170 mm x 120 mm (Diameter x Height)

Cephalometric exams (CEPH version only)

Lateral projections	formats 18x24 cm, 24x24 cm, 30x24 cm and 18x18 cm, 24x18 cm, 30x18 cm
Antero-posterior projections	format 24x24 cm and 24x18 cm
Carpus exam	format 18x24 cm

Note of cephalometric image formats:

For operator convenience, the CEPH projections are named following the conventional format of the film-cassettes (24 cm), although the vertical active area of the cephalometric sensor is 22.8 cm.

(*) In case the 80x80 FOV limitation setting (i.e. “Unit has 8x8 shield” setting) is enabled, the values will change to: 3D Dentition 80 mm x 80 mm (Diameter x Height), 3D Single Jaw (Mandibular and Maxillary) to 80x50 mm and both the Full Arch/100x120 airways and Extended Arch FOVs will NOT be available. To activate this setting, refer to the service manual.

(**) Given the shape of the FOV (whose section is shown in Figure 3), the height measurement indicated for the Extended Arch (i.e. 120 mm) represents the maximum height of the FOV.

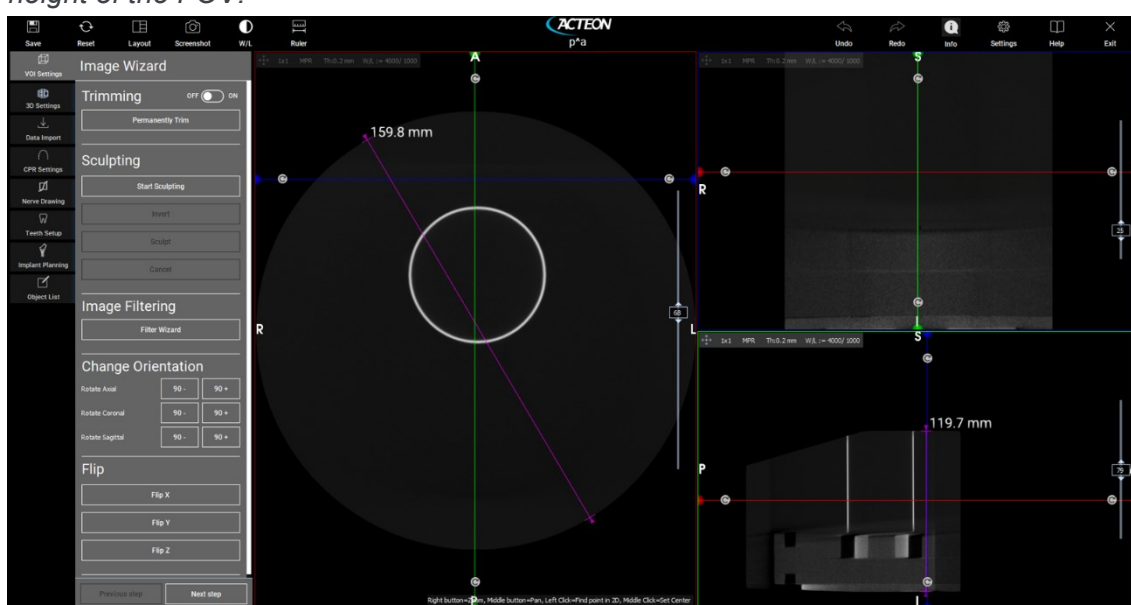

Figure 3: Extended Arch FOV section.

Image magnification	Geometric magnification	Magnification after software correction
Adult / Child standard Panoramic	1 : 1.28 (constant over dentition part)	1 : 1 (*)
TMJ closed/open mouth	1 : 1.25 (nominal)	1 : 1 (*)
Sinus	1 : 1.27 (nominal)	1 : 1 (*)
Cephalometric exams (CEPH version only)	1 : 1.1 (nominal)	1 : 1 (*)
Carpus exam (CEPH version only)	1 : 1.06 (nominal)	1 : 1 (*)



(*) Warning

The declared image magnification value is valid after proper software calibration.

**Note**

x-mind optima 3D is based on a standard dentition and ascending rami shape. This shape, based on statistical studies, establishes a form for the dentomaxillofacial complex, adopted as "standard". x-mind optima 3D follows a rototranslation path which maintains the magnification factor as stated in the Technical Characteristics of each type of exam as constant along this "standard" shape and in the dentition area. The patient's anatomy can differ significantly from the statistical model, so the magnification factor is not maintained and can be different from the value stated. Based on his experience and competence, the operator has to judge this variation. **IN ANY CASE, RADIOGRAPHY IMAGES CANNOT BE USED TO PERFORM CALCULATIONS OF DISTANCES, ANGLES ETC. ON THE IMAGE.**

Tube-head characteristics

Model	MPV03 or MPV05
Manufacturer	de Götzen S.r.l. 21054 Fagnano Olona (VA) - Italy
Maximum tube voltage	90 kV
kV accuracy	± 8 %
Maximum anodic current	12.5 mA
Anodic current accuracy	± 10 %
Duty cycle	1 : 16
Reference loading conditions related to maximum energy input to the anode	2812.5 mAs/h @ 90 kV
Nominal power	1.125 kW (90 kV – 12.5 mA)
Total filtration	≥ 2.5 mm Al eq. @ 90 kV
HVL (Half value layer)	> 3.2 mm Al eq. @ 90 kV
Transformer insulation	Oil bath
Target angle and reference axis	See Figure 4
Cooling	By convection
Leakage radiation at 1 m	< 0.5 mGy/h @ 90 kV – 12.5 mA – 3 s duty cycle 1/16
Tube-head maximum thermal capacity	310 kJ

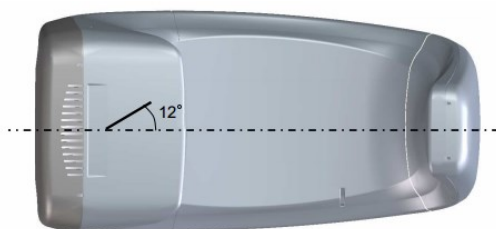

Figure 4: Tube-head target angle (view from the bottom)

X-ray tube characteristics

MPV03

Manufacturer	CEI
Type	OX – 120 – 0307
Nominal focal spot	0.3 EN 60336
Inherent filtration (permanent)	0.5 mm Al eq. @ 90 kV
Anode tilt	12°
Anode material	Tungsten
Nominal maximum voltage	120 kV
Filament max current	3.5 A
Filament max voltage	3 V
Anode thermal capacity	33 kJ
Anode thermal capacity during continuous operation	280 W

MPV05

Manufacturer	CEI
Type	OPX 105-12
Nominal focal spot	0.5 EN 60336
Inherent filtration (permanent)	0.8 mm Al eq. @ 90 kV
Anode tilt	12°
Anode material	Tungsten
Nominal maximum voltage	110 kV
Filament max current	4 A
Filament max voltage	6.7 V
Anode thermal capacity	30 kJ
Anode thermal capacity during continuous operation	300 W

Laser centering devices

2 laser beams are used for patient positioning; beams that align the sagittal and Frankfurt planes (please refer to relevant paragraphs for a detailed explanation).

LN60-650

Wave length	650 nm
Divergence	< 2.0 mRad
Optical power on the working surface	< 1 mW
Laser class	Class 1 laser product according to IEC standard 60825-1:2014

LN60-635

Wave length	635 nm
Divergence	< 2.0 mRad
Optical power on the working surface	< 1 mW

Laser class	Class 1 laser product according to IEC standard 60825-1:2014
03015L	
Wave length	650 nm
Divergence	< 2.0 mRad
Optical power on the working surface	< 1 mW
Laser class	Class 1 laser product according to IEC standard 60825-1:2014
IDT065001P	
Wave length	640 nm
Divergence	< 2.0 mRad
Optical power on the working surface	< 0.39 mW
Laser class	Class 1 laser product according to IEC standard 60825-1:2014

3D Digital sensor

Detector type	CMOS or IGZO flat panel
Sensitive Area (H x L)	139.2 : 150.5 x 113.7 : 119.6 mm CMOS
	159.5 : 169.3 x 159.5 : 169.3 mm IGZO
Pixel dimensions	98-120 μ m 200-240 μ m (2x2 binning)
Number of pixels (H x L) CMOS flat panel	656:822 x 616:748 600:734 x 494:604 (2x2 binning)
Number of pixels (H x L) IGZO flat panel	728:823 x 664:750 766:814 x 766:814 (2x2 binning)
Voxel dimensions CMOS flat panel	143-175 μ m HD mode 71.5-87.5 μ m XD mode (only in the models for which is intended)
Voxel dimensions IGZO flat panel	143-161 μ m HD mode 70.0-71.5 μ m XD mode (only in the models for which is intended)
Grey levels	65536 (16 bit)
Resolution	Up to 5.10 lp/mm (non binning mode)
Sensor cover attenuation equivalent	< 0.4 mm Al eq.

Cephalometric Digital sensor (CEPH version only)

Detector type	CMOS detectors with CSI scintillator
Sensitive Area (H x L)	228 x 6.7 mm
Pixel dimensions	99 μ m 198 μ m (2x2 binning)
Number of pixel (H x L)	2304 x 68 (non-binning mode)
Grey levels	16384 (14 bit)
Resolution (spatial frequency at CTF=5%)	5 lp/mm (non-binning mode)
Sensor cover attenuation equivalent	< 0.4 mm Al eq.

Mechanical characteristics

Focal spot to image receptor distance (panoramic and 3D)	52 cm (20")
Focal spot to image receptor distance (cephalometric)	165 cm (65")
Telescopic motorised column run	66 cm (26")
Telescopic motorised column run (floor mounted version)	70 cm (28")
Telescopic motorised column run (CEPH version)	70 cm (27"1/2)
Maximum total height Note: For the wall mount model this value refers to the recommended installation height	219 cm (86")
Maximum total height (floor mounted version)	223 cm (88")
Maximum total height (floor mounted-self standing version)	225 cm (89")
Maximum total height (CEPH version)	223 cm (88")
Weight (wall version)	70 kg
Column base (optional x-mind optima 3D only)	6 kg
Weight (floor version)	86 kg
Weight (CEPH version)	126 kg (278 lbs)

Environmental conditions

Minimum room size	120 x 115 cm
Recommended room size (please refer to the relevant Service Manual)	160 x 150 cm
Minimum room size CEPH version (please refer to the relevant Service Manual)	186 x 121 cm (75"x49")
Recommended room size CEPH version (please refer to the Service Manual)	200 x 130 cm (80"x52")
Minimum room size floor-mounted/floor mounted self-standing version (please refer to the relevant Service Manual)	186 x 121 cm (75"x49")
Recommended room size floor-mounted/floor mounted self-standing version (please refer to the relevant Service Manual)	200 x 130 cm (80"x52")
Working temperature range	+ 10°C ÷ + 35°C
Working relative humidity (RH) range	30% ÷ 75%
Working atmospheric pressure range	700 ÷ 1060 hPa

Temperature range for transport and storage	- 20°C ÷ + 70°C
Humidity range for transport and storage	< 95% without condensation
Minimum atmospheric pressure for transport and storage	630 hPa

**Note**

The handles of the equipment are covered with a special antibacterial paint which, thanks to the emission of silver ions, reduces the development of micro-organisms.

6.1 Dimensions

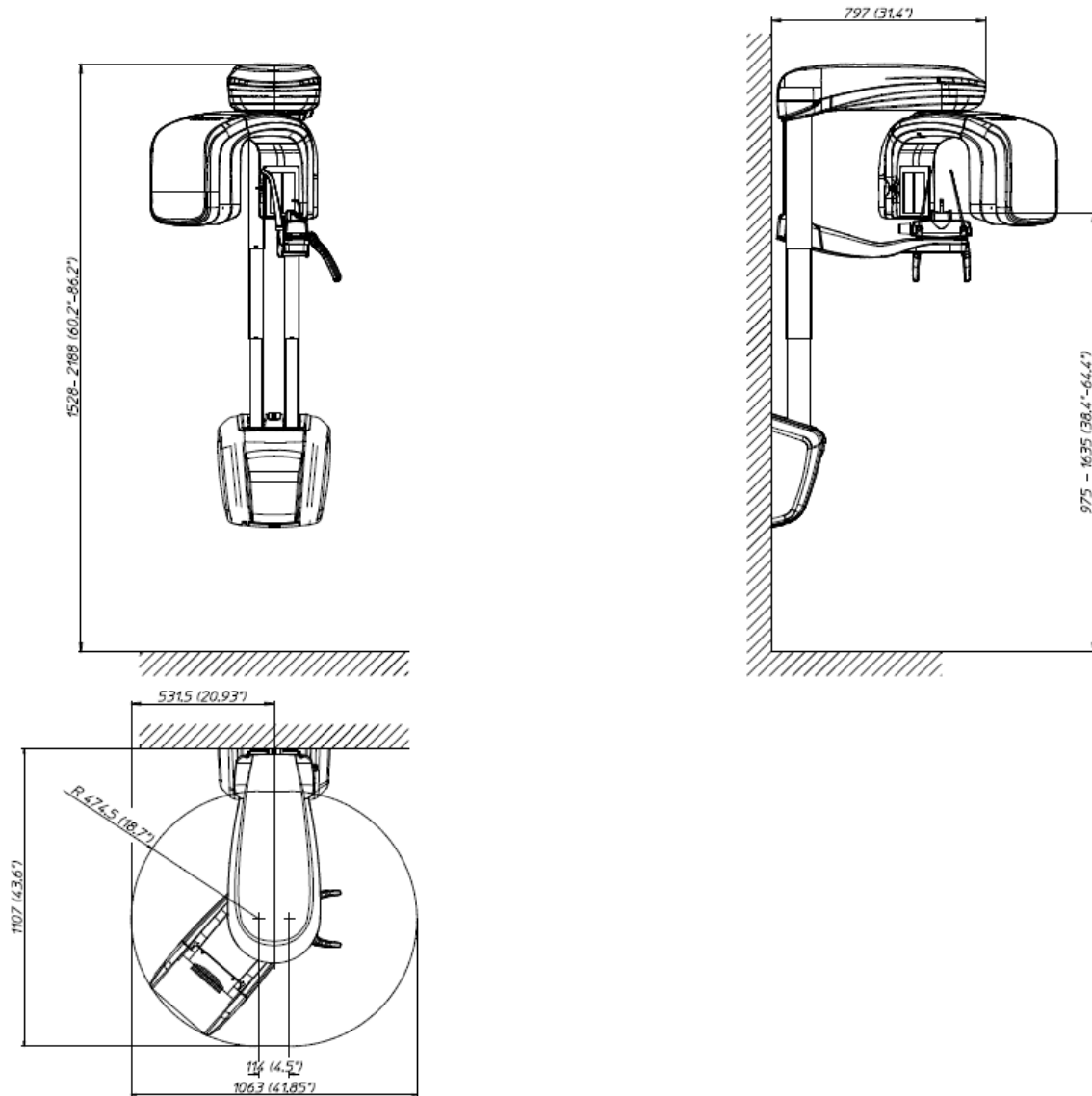

Figure 5: x-mind optima 3D dimensions - Wall mounted version

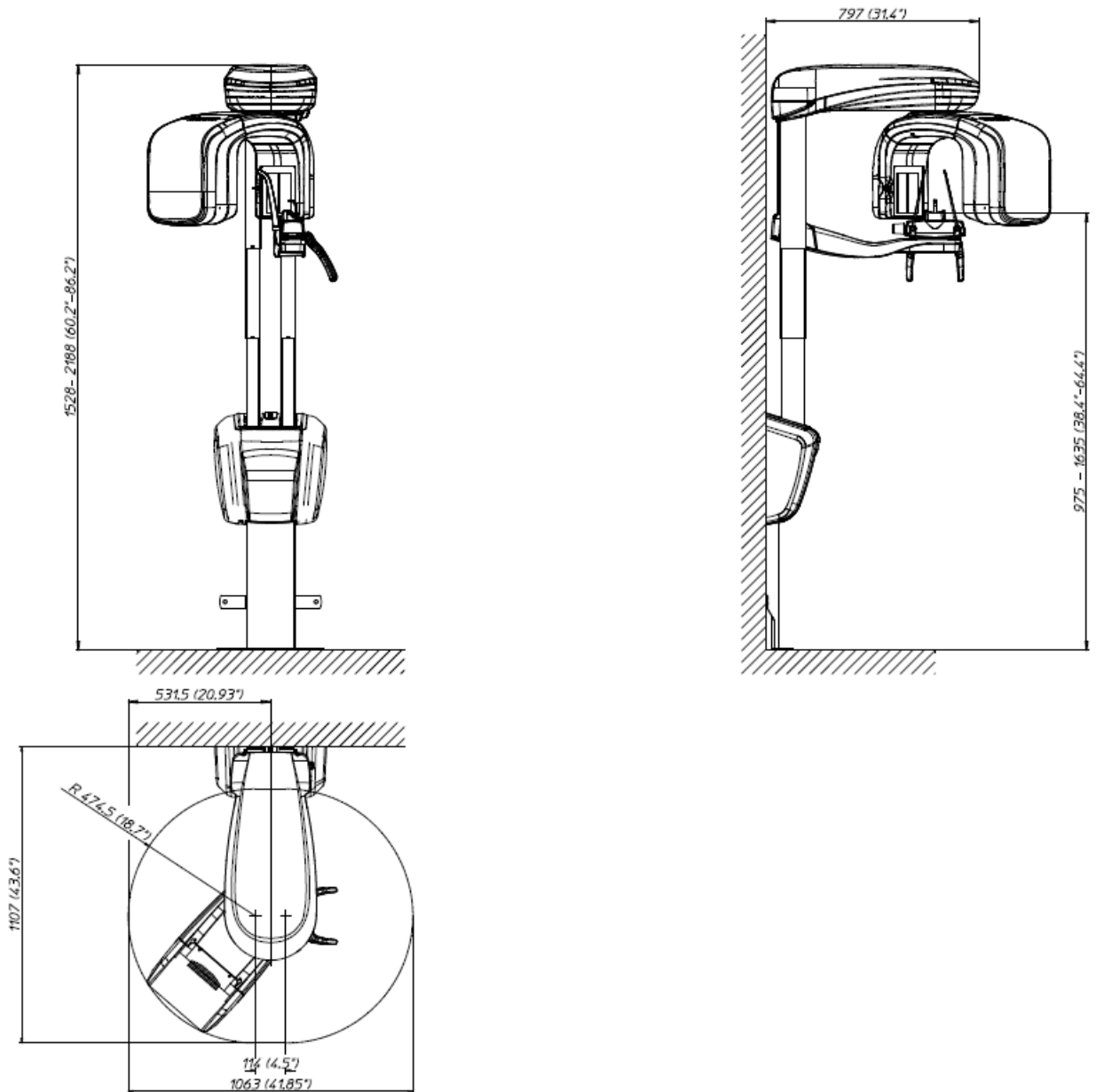

Figure 6: x-mind optima 3D dimensions Wall mounted with floor support version

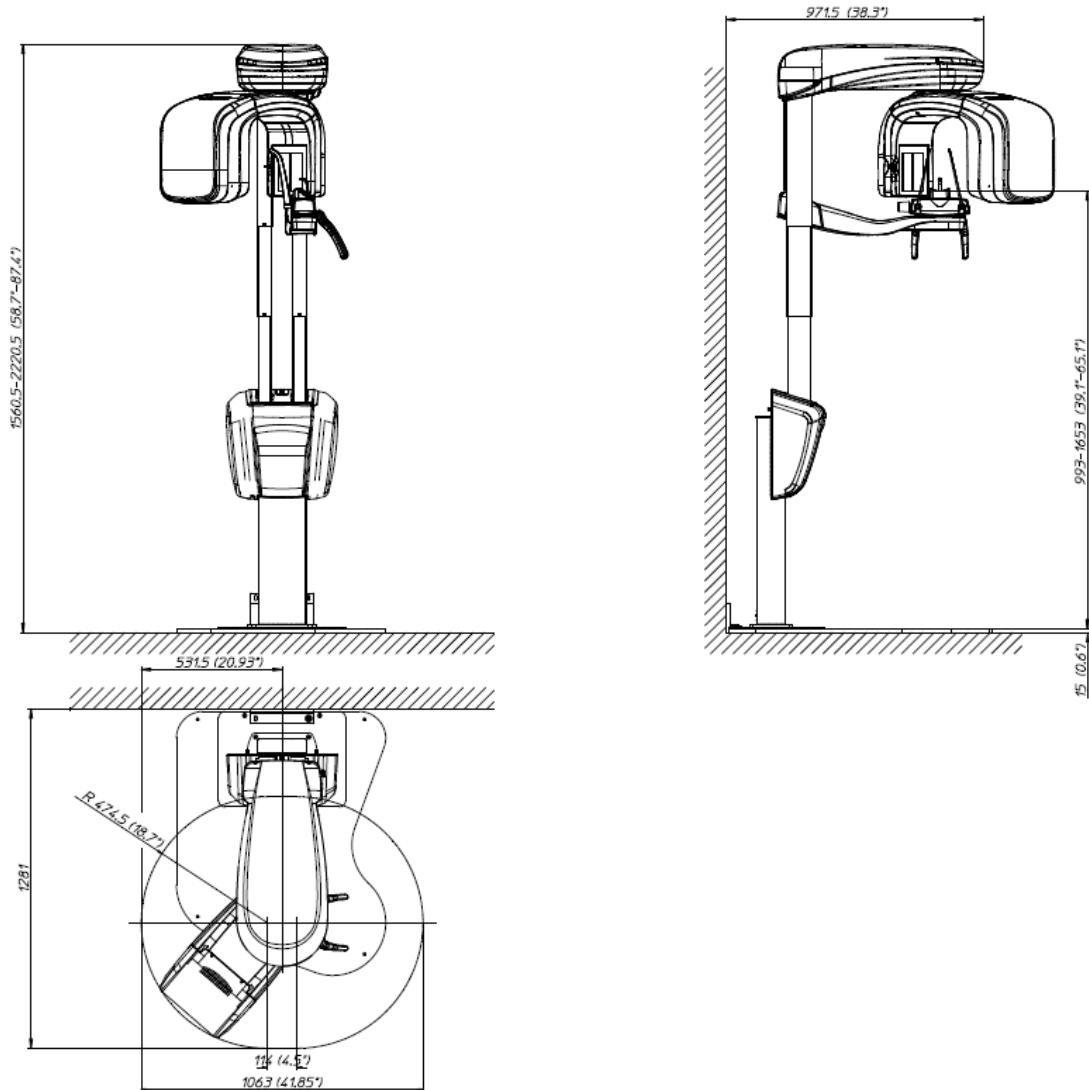

Figure 7: x-mind optima 3D dimensions – Self-standing on the floor version

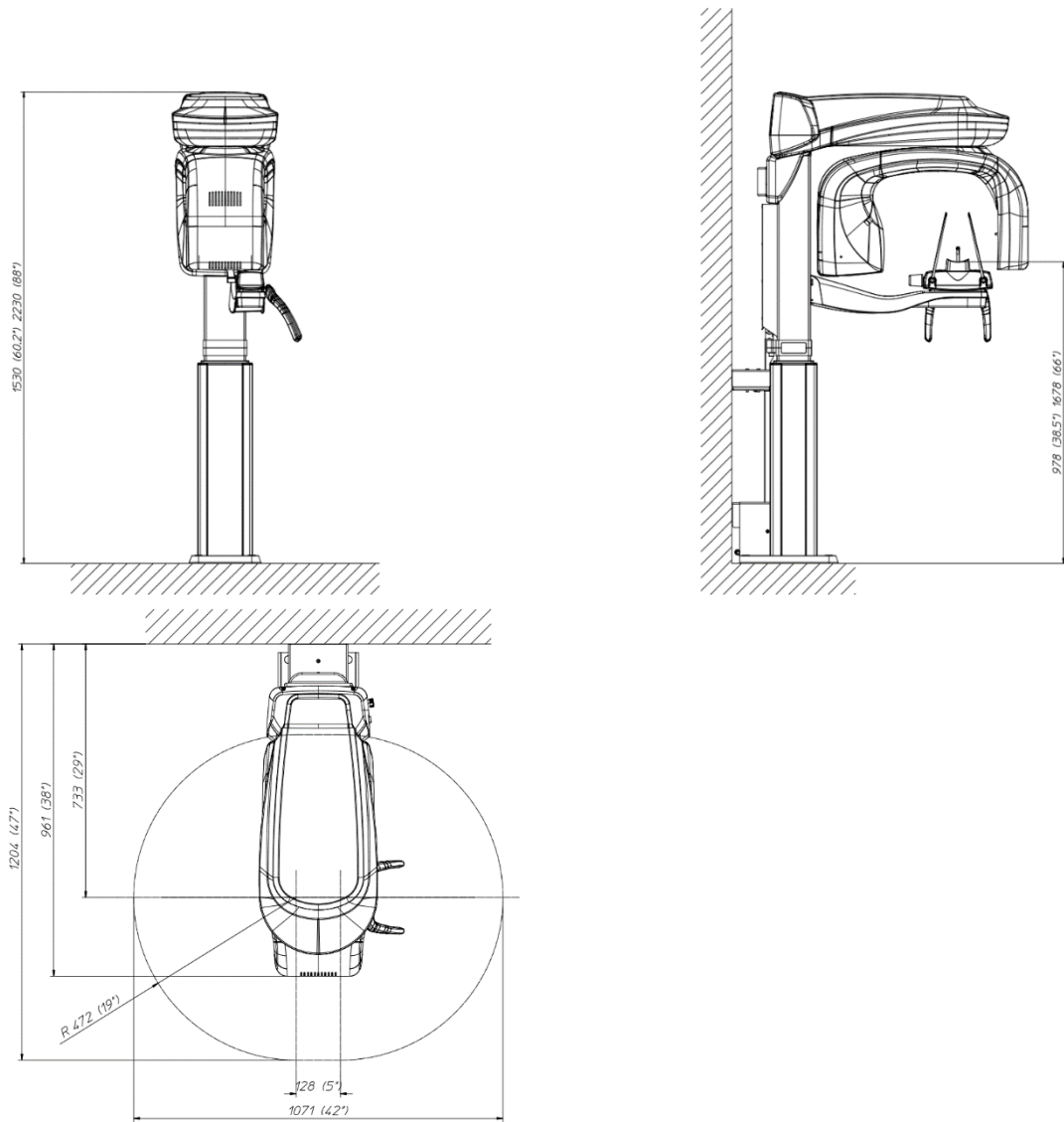

Figure 8: x-mind optima 3D dimensions – Floor mounted version

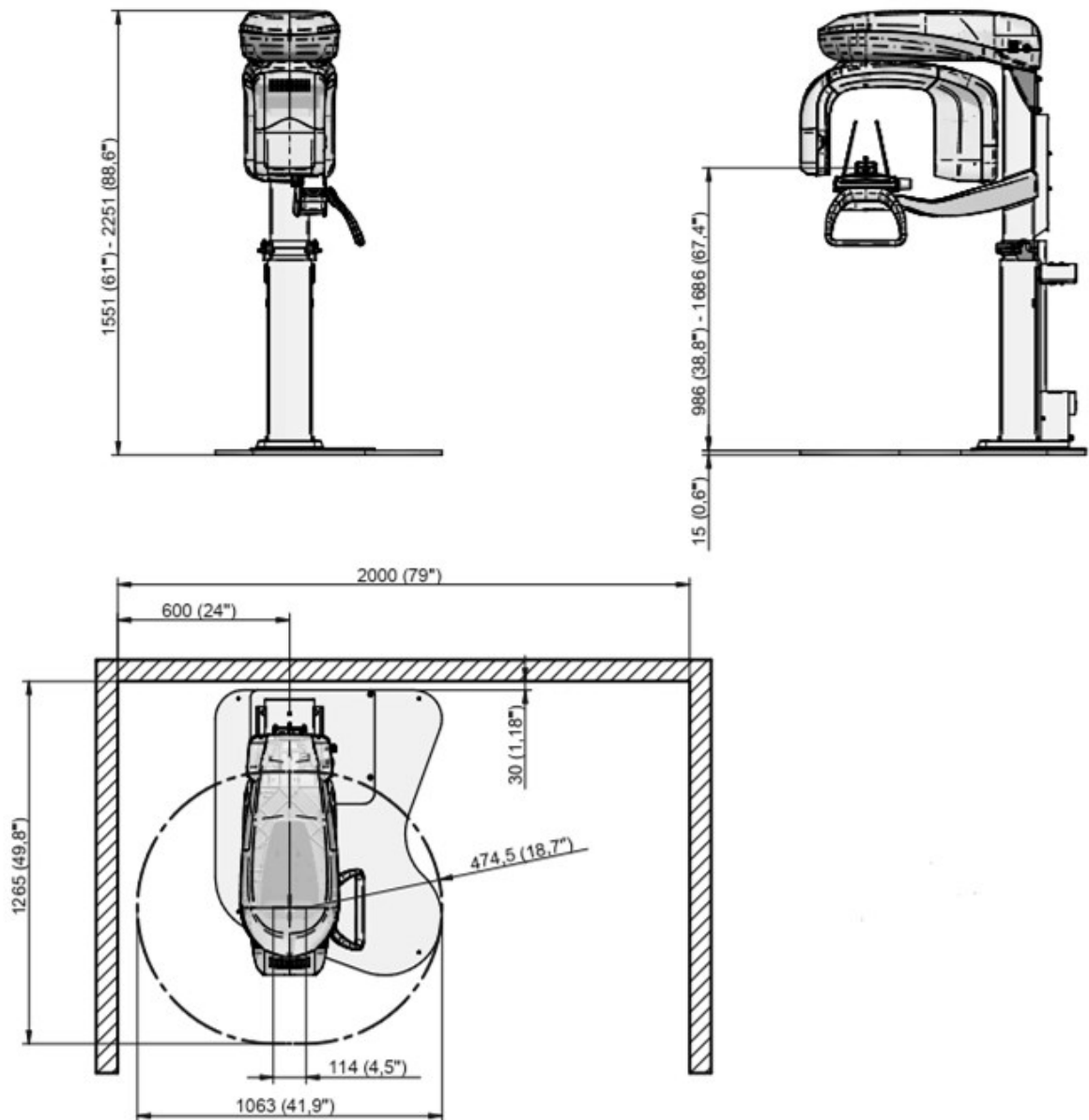

Figure 9: x-mind optima 3D dimensions – Floor self-standing mounted version

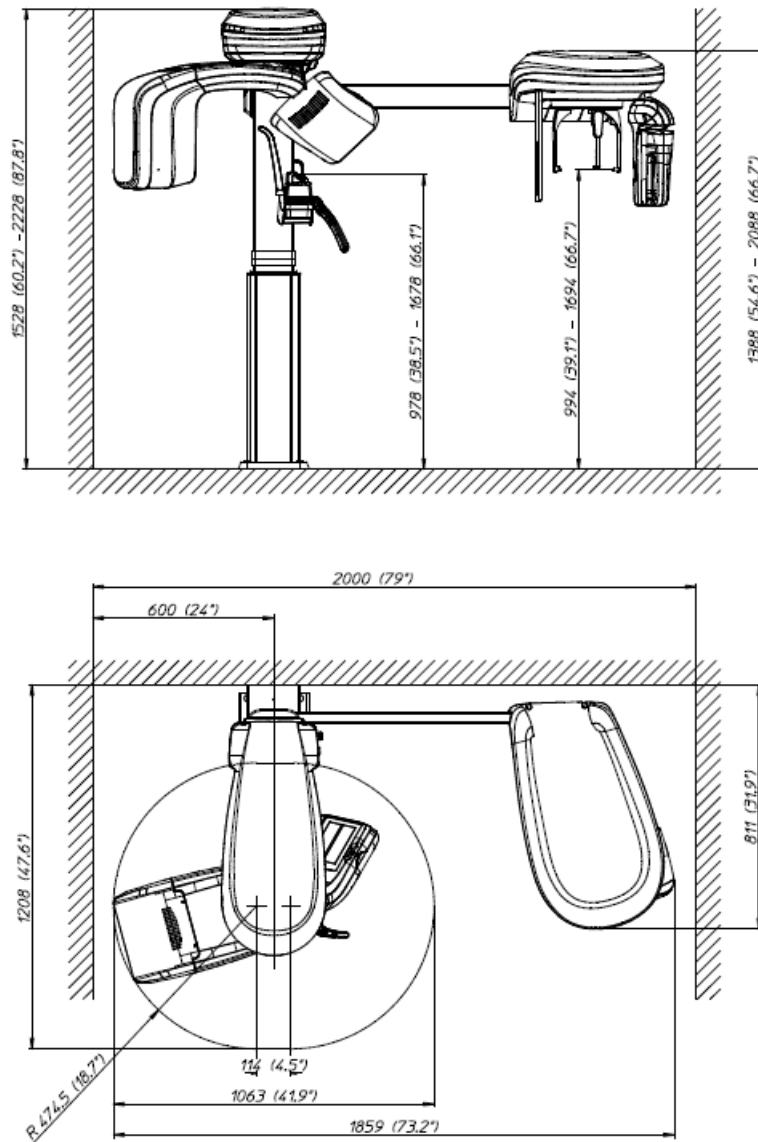

Figure 10: x-mind optima 3D ceph dimensions – Floor mounted version

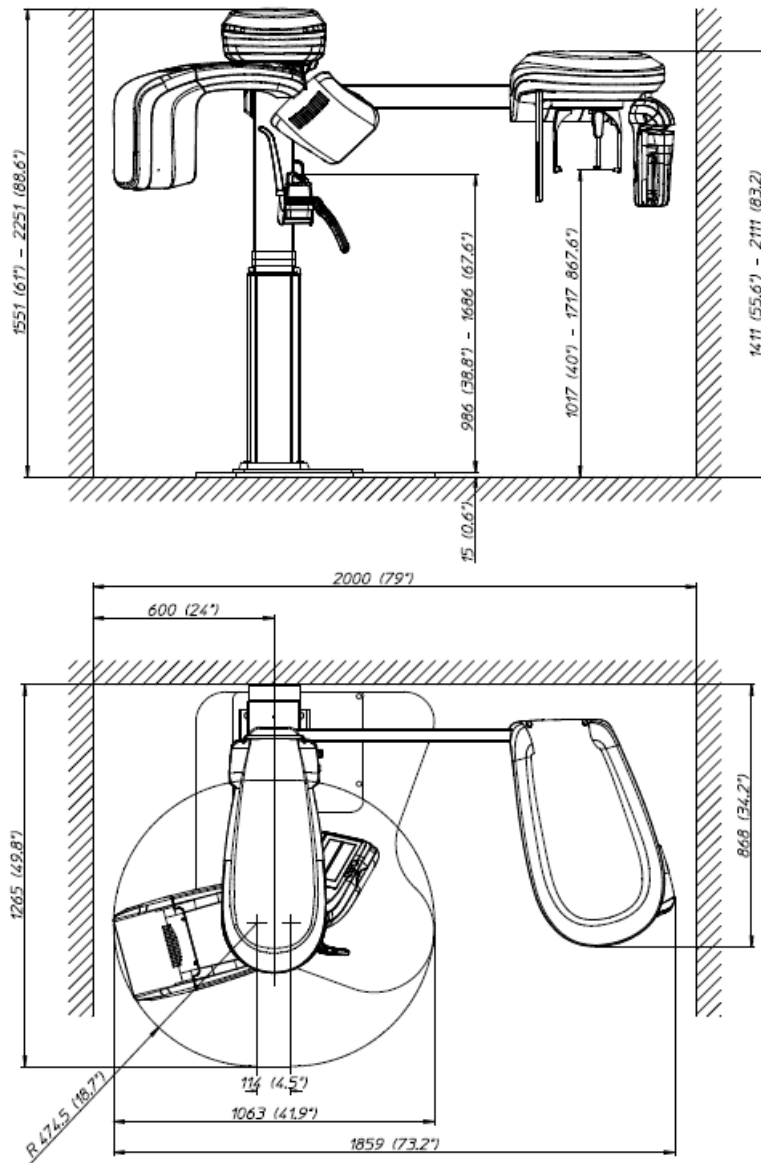

Figure 11: x-mind optima 3D ceph dimensions – Free standing version



Warning for free standing floor mounted unit

In case the unit shall be moved for service or other extraordinary operation, maximum caution shall be taken to prevent the unit from tilting and falling to the ground.

6.2 Tube loading curves, anode heating and cooling curves

Tube "CEI OPX 105-12" (0.5 IEC 336)

Tube loading curves

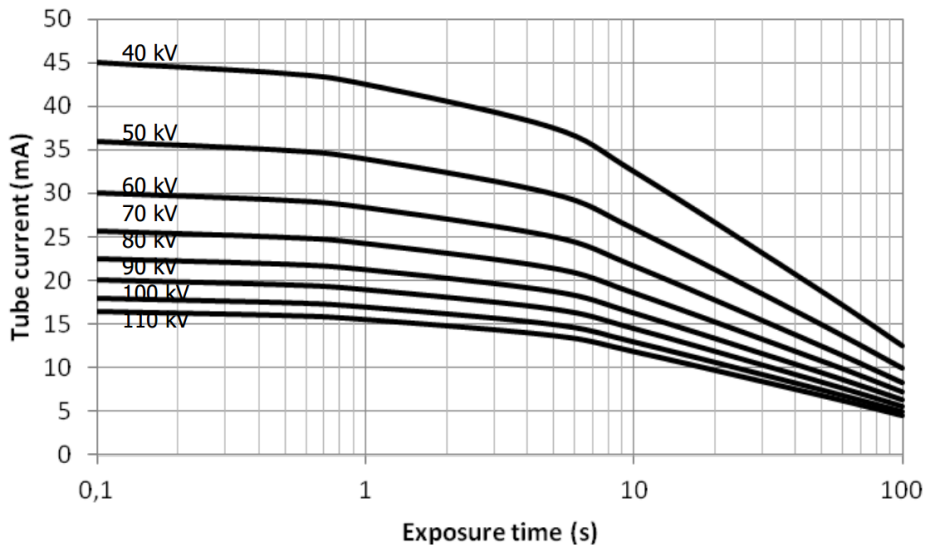

Anode heating and cooling curves

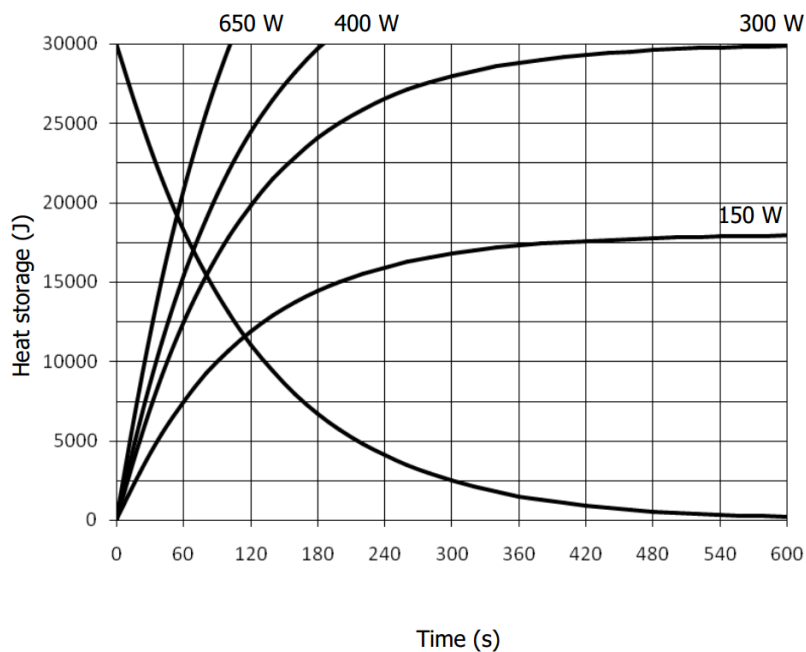

Tube head cooling curve

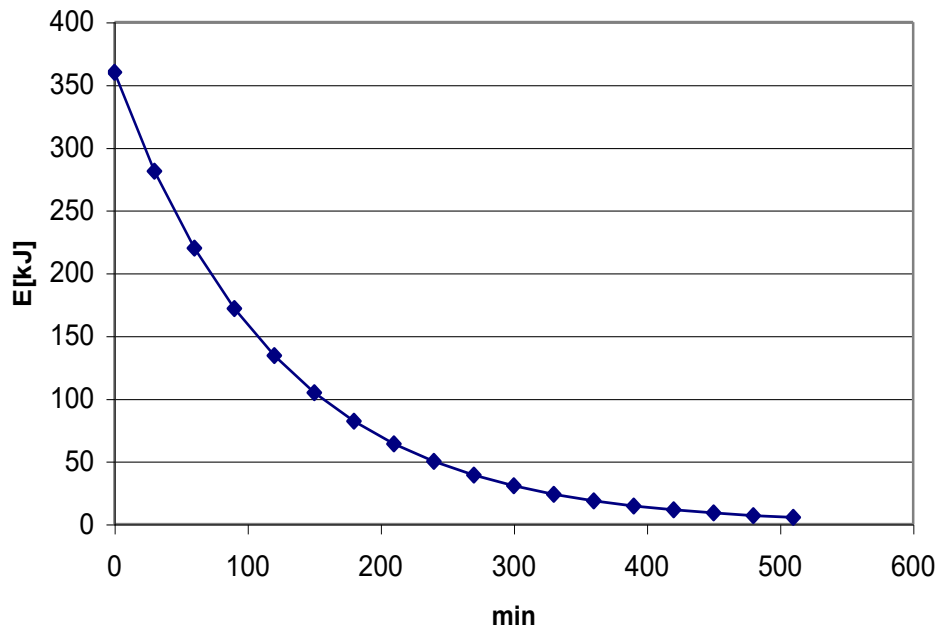

Tube "CEI – OX – 120 - 0307" (0.3 IEC 336)

Tube loading curves

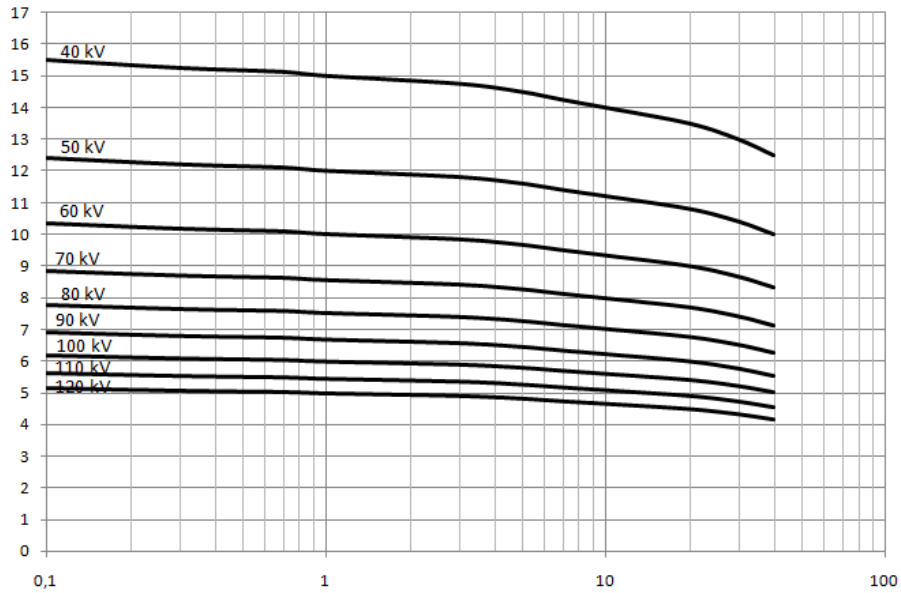

Anode heating and cooling curves

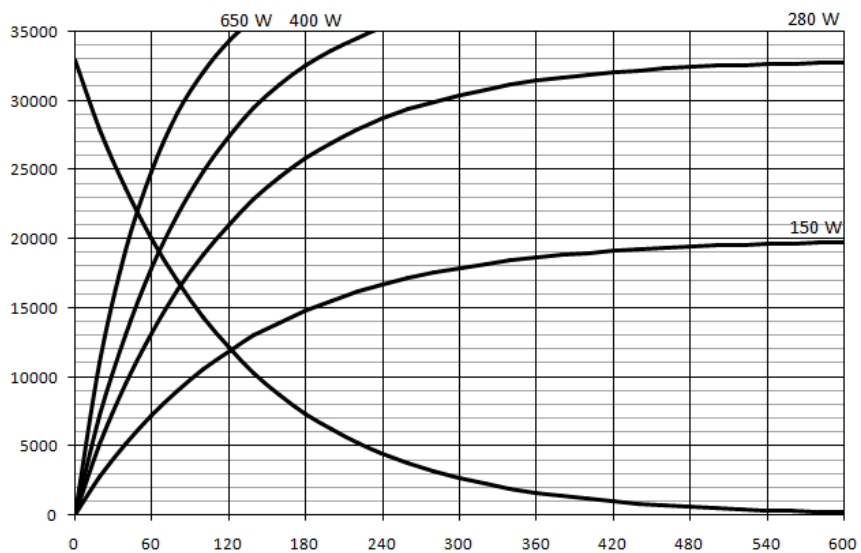

6.3 PC requirements



Warning

PC to be used with the machine must comply with the standard IEC 62368-1:2018/COR1:2020.

6.3.1 Characteristics of the supplied workstation (only for XMO 3D with supplied Workstation)

The workstation supplied with the equipment has the following characteristics:

- Processor Intel Core i7 (4 cores 8 threads) 3 GHz or higher.
- 16 GB RAM.
- Hard drive 1TB.
- Hard disk SSD 256 GB
- DVD recorder.
- GPU cards with the following specifications (i.e. NVIDIA® QUADRO® P2000/P2200, NVIDIA T1000 or NVIDIA RTX A2000):
 - chipset Nvidia
 - Global memory: 5 GB for QUADRO® P2000/P2200
4GB for NVIDIA T1000
6GB for NVIDIA RTX A2000
 - Capability (=architecture): Pascal for QUADRO® P2000/P2200
Touring for NVIDIA T1000
Ampere for NVIDIA RTX A2000
- Operating Equipment Windows: 10/11 – 64 bit.

Monitor characteristics:

- Resolution: 1920 x 1080 pixels
- Colour depth: 16M of colour
- Contrast: 1000:1
- Luminosity: 250 cd/m²

6.3.2 PC suggested characteristics

- Mother board with at least one free PCI express X16 slot (mandatory for the Dual Port Network Card provided with the machine).
- Processor Intel Core i7 (4 cores 8 threads) 3 GHz or higher.
- 8 GB Ram.
- Hard drive 1TB.
- DVD recorder.
- Graphics card with the following specifications (ex : NVIDIA® QUADRO® T1000):
 - chipset Nvidia
 - Global memory \geq 4 GB
 - Capability (=architecture) \geq Maxwell.
- Operating Equipment Windows 10 - 64bit.

**Note**

In order to properly view images taken with x-mind optima, the PC monitor must have the following minimum characteristics:

- Resolution: 1600 x 1024 pixels
 - Colour depth: 16M of colour
 - Contrast: 500:1
 - Luminosity 200 cd/m²
-

**Note**

Using a PC with lower characteristics, the High Definition mode of 3D is not supported.

**Note**

Below are reported the available compatible resolution for AIS software:

- 4K: 4096x2160 px
 - 1440p: 2560x1440 px
 - Full HD: 1920x1080px
 - HD+: 1366x768px
 - HD: 1280x720px
-

6.4 Software

The equipment Graphical Operator Interface can be run with the software provided with the machine or integrated in a third party imaging and database software that complies with the following specifications: it has to be CE marked as medical device of class IIa and integrate the equipment SDK according to what stated in the document PANOW3D API programmer's guide Vn (n is the document revision). Contact Acteon to have the latest revision of the programmer's document.

The 3D exams can be viewed with any software that can import, view and manage 3D volumes saved in DICOM slices with the following maximum dimensions:

- Normal resolution 10X12 full volume: 687 slices, 572x572 pixels per slice, 12 or 16 bits, for a total of 1259 kB/slice;
- Normal resolution Extended Arch: 79 slices, 808x808 pixels per slice, 12 or 16 bits, for a total of 2461 kB/slice;
- Full resolution 50x50 XH volume: 781 slices, 738x738 pixels per slice, 12 or 16 bits, for a total of 1078 kB/slice.

6.5 x-mind optima 3D – PC communication

x-mind optima 3D requires connection to a host PC to transfer images and to exchange the machine status. The communication between x-mind optima 3D and computer requires two dedicated Giga-Ethernet channels that are provided by the dual port Network Interface Card supplied with the unit.

The information flow from x-mind optima 3D includes image data and equipment status messages that are exchanged only with the host PC via a point-to point connection separated from the rest of the network. The communication requires fixed IP addresses. The two Ethernet cables from the unit must be connected to such ports for the unit to operate correctly.

In order to properly operate the unit, follow carefully the instructions reported in the Service Manual at paragraph 7.6.

The equipment is provided with 2 Ethernet Cat 6 cables in order to permit the PC connection. In case of replacement, cables of the same or superior category have to be used.

If the communication between x-mind optima 3D and PC is not properly set problems in unit connection causing impossibility of acquisition or loss of frames causing distortion and artefacts on the images can occur.



Note

x-mind optima 3D is not intended to transmit or receive information to/or from other equipment through network/data couplings.

6.6 Reference standard

Medical electrical equipment for extra-oral dental radiography x-mind optima 3D complies with:

- *EN ISO 13485:2016/A11:2021*
- *EN ISO 14971: 2019/A11:2021*
- *ISO/TR 24971:2020*
- *EN ISO 15223-1:2021*
- *EN ISO 20417:2021*
- *EN ISO 10993-1:2021*
- *IEC 60601-1:2005 + A1:2012 + A2:2020 (ed.3.2)*
- *IEC 60601-1-2:2014 + A1:2020*
- *EN 60601-1-2:2015 + A1:2021*
- *IEC 60601-1-3:2008/A1:2013/A2:2021*
- *IEC 60601-1-6: 2010/A1:2013/A2:2020*
- *IEC 62366-1:2015 + AMD1:2020*
- *IEC 60601-2-63:2012/A1:2017/A2:2021*
- *IEC 62304:2006 AMD1 2015 (Identical to EN 62304:2006/A1:2015)*
- *IEC 60529:1989/AMD2:2013/COR1:2019*
- *IEC 60825-1:2014*
- *IEC 62353:2014*
- *IEC TR 62354:2014*
- *MDCG 2019-16*
- *21 CFR 803 MEDICAL DEVICE REPORTING*
- *21 CFR 806 - Subchapter H- Medical Devices –Part 806 Medical Devices; Report Corrections and Removals*
- *21 CFR 807- ESTABLISHMENT REGISTRATION AND DEVICE LISTING FOR MANUFACTURERS AND INITIAL IMPORTERS OF DEVICES*
- *21 CFR 820- QUALITY SYSTEM REGULATION*
- *21 CFR 821 – MEDICAL DEVICE TRACKING REQUIREMENTS*
- *47 CFR § 15.231*
- *Periodic operation in the band 40.66-40.70 MHz and above 70 MHz*
- *21 CFR 1020.31*
- *Radiographic equipment*
- *21 CFR 1020.30*
- *Diagnostic X-ray systems and their major components.*
- *ANSI AMI 60601-1:2006*
- *Therapeutic Goods (Medical Devices) Regulations 2002*
- *Brazilian Health Surveillance Agency*
- *Resolution RDC 16 2013*
- *Resolution RDC 501/2021*
- *Resolution RDC 67 2009*
- *Resolution RDC 751/2022*
- *Brazilian Ordinance nº 384:2020 - INMETRO*
- *Resolution RDC 751/2022*

CE 0051 Guarantees the compliance of x-mind optima 3D with Regulations 745/2017/EU (as amended), 2011/65/EU, 2006/42/EC.

Classifications

x-mind optima 3D is an electrical medical X-ray device classified as class I type B according to EN 60601-1, with continuous operation and intermittent load.

According to 745/2017/EU Medical Devices Regulation, the equipment is classified as class II B.

According to Canadian MDR, the equipment belongs to class II.

According to FDA 21 CFR, the equipment belongs to class II.

6.7 CBCT Conditions of Operation

The following table lists the conditions of operation for the unit working in CBCT modality.

Quantity	Range
Tube current (mA)	from 2 to 12.5 mA
kV	from 60 to 90 kV
Exposure time	21.2 s
X-ray filtration	≥ 2.5 mm Al eq. @ 90 kV
Nominal Tomographic section thickness	0.144 mm (0.072 mm in XD resolution - only in the models for which is intended)
Image receptor area	139.2 : 144.0 x 118.6 : 119.6 mm

6.7.1 Reference Plane

The reference plane offset is the horizontal plane passing on the chin rest of the unit. The Figure 12 shows the position of the reference plane and its location with respect to the chin rest, the focal spot and the irradiated volume by the X-ray cone beam. Each exam has a proper chin support that gives the proper reference plane offset.

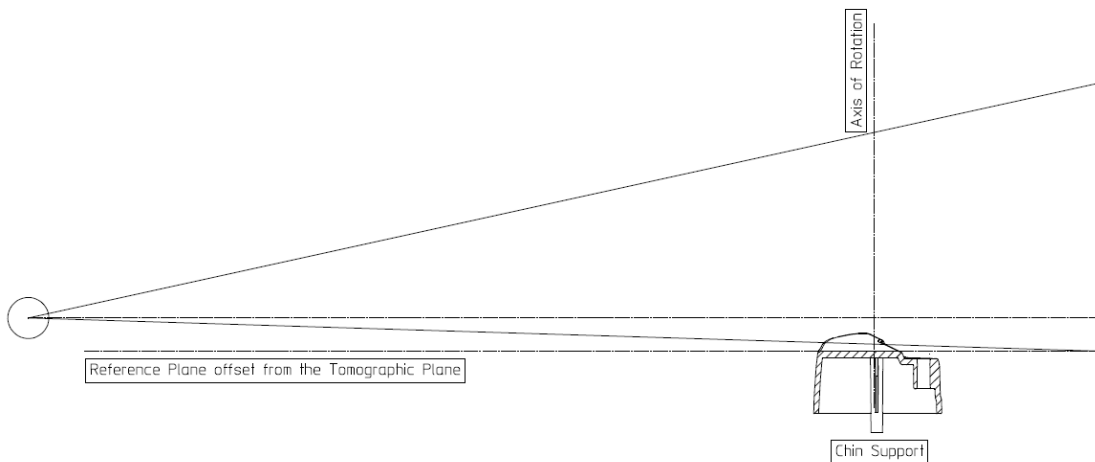

Figure 12

6.8 CTDI information

The following dose information are measured using a dosimetry head phantom compliant with the specifications of CFR 21 1020.33.

The phantom is a circular cylinder of polymethyl-methacrylate (PMMA) of density 1.19 ± 0.01 grams per cubic centimeter. The phantom is 15.0 centimeters high and has a diameter of 16.0 centimeters since the equipment is designed to image the head (head scanners).

The phantom has holes just large enough for the placement of a dosimeter(s) along its axis of rotation and along a line parallel to the axis of rotation 1.0 centimeter from the outer surface and within the phantom.

Values were measured as CTDI₁₀₀ as recommended in the FDA Guidance doc. "Provision for Alternate Measure of the Computed Tomography Dose Index (CTDI) to Assure Compliance with the Dose Information Requirements of the Federal Performance Standard for Computed Tomography" of October 20.2006.

6.8.1 Measure conditions

The conditions of operations are set according to the following table:

Quantity	Range
Tube current (mA)	from 2 to 12.5 mA
kV	from 60 to 90 kV
Scan time	20.4 s
X-ray filtration	≥ 2.5mm Al eq. @ 90 kV
Nominal Tomographic section thickness	0.161 mm (0.070 mm in XD resolution - only in the models for which is intended)
Image receptor area	139.2 : 169.3 x 118.6 : 169.3 mm

6.8.2 Measurement procedure

1. The phantom is placed on the support of the chin rest of the machine.
2. The dose detector is placed in the phantom in one of the positions at a time.
3. The default values for adult and normal size (90 kV – 5 mA) are selected.
4. An exposure is performed.
5. The dose measure is recorded.

6.8.3 Measured values

Different dose measurements are performed to find the location of the plane where the dose measurement at 1 cm interior from the surface of the phantom is maximum.

Such location is perpendicular to the mid-sagittal line of the imaged volume on the right side of the patient considering the patient's orientation. The other Measurement Locations refer to 90° steps clockwise.

Measurements are made both with and without phantom (measurement without phantom from now on will be referred to *CTDI free air*)

6.8.4 Measured Dose values for other conditions of operation

The following table lists the relative CTDI values:

CTDI_w results (FOV 85x93):

Position	kV	mA	t scan [s]	Patient type (normal size)	CT [mGy*cm]	CTDI ₁₀₀ * [mGy]	CTDI ₁₀₀ / CTDI _{100st} d
Border (0°)	90	5	20,4	Adult	66.88	7.18	1.19
Border (0°)	66	6.3	20,4	Child	37.62	4.04	0.67
Border (90°)	90	5.0	20,4	Adult	56.03	6.02	0.99
Border (90°)	66	6.3	20,4	Child	32.91	3.53	0.58
Border (180°)	90	5.0	20,4	Adult	69.26	7.44	1.23
Border (180°)	66	6.3	20,4	Child	37.69	4.05	0.67
Border (270°)	90	5.0	20,4	Adult	30.63	3.29	0.54
Border (270°)	66	6.3	20,4	Child	11.82	1.27	0.21
Center	90	5.0	20,4	Adult	56.33	6.05	1.00
Center	66	6.3	20,4	Child	29.28	3.14	0.52

*CTDI₁₀₀= CT/(N*T)

N = 578

T = 0.0161075

Adult

CTDI_{100,peripheral} = 5.98 mGy

CTDI_w = **6.0 mGy**

CTDI_{vol} = n * CTDI_w = 1 * CTDI_w = CTDI_w = **6.0 mGy**

Child

CTDI_{100,peripheral} = 3.22 mGy

CTDI_w = **3.2 mGy**

CTDI_{vol} = n * CTDI_w = 1 * CTDI_w = CTDI_w = **3.2 mGy**

CTDI_{free air} – different voltage results (FOV 85x93):

Patient	Current (mA)	t scan [s]	Voltage (kV)	CTDI _{100, free air} (mGy)		
				Value	Nom. value	Diff %
Adult Medium	5	20.4	60	Value	Nom. value	Diff %
				6.38	6.34	0.60
Adult Medium	5	20.4	62	Value	Nom. value	Diff %
				6.87	6.87	0.00
	5	20.4	64	Value	Nom. value	Diff %

Adult Medium				7.31	7.39	-1.01
Adult Medium	5	20.4	66	Value	Nom. value	Diff %
				7.73	7.64	1.21
Adult Medium	5	20.4	68	Value	Nom. value	Diff %
				8.43	8.37	0.76
Adult Medium	5	20.4	70	Value	Nom. value	Diff %
				8.91	8.84	0.71
Adult Medium	5	20.4	72	Value	Nom. value	Diff %
				9.44	9.40	0.43
Adult Medium	5	20.4	74	Value	Nom. value	Diff %
				10.00	9.89	1.06
Adult Medium	5	20.4	76	Value	Nom. value	Diff %
				10.83	10.74	0.82
Adult Medium	5	20.4	78	Value	Nom. value	Diff %
				11.36	11.29	0.65
Adult Medium	5	20.4	80	Value	Nom. value	Diff %
				11.94	11.90	0.35
Adult Medium	5	20.4	82	Value	Nom. value	Diff %
				12.30	12.21	0.72
Adult Medium	5	20.4	84	Value	Nom. value	Diff %
				13.24	13.24	0.00
Adult Medium	5	20.4	86	Value	Nom. value	Diff %
				13.91	13.85	0.46
Adult Medium	5	20.4	88	Value	Nom. value	Diff %
				14.65	14.59	0.44
Adult Medium	5	20.4	90	Value	Nom. value	Diff %
				15.05	15.01	0.23

CTDI_{free air} – different FOV results:

Patient	FOV	Resolution	Current (mA)	t scan [s]	Voltage (kV)	CTDI _{100, free air}	CTDI ₁₀₀ /CTDI _{100std}
Adult Medium	50x50 L molar**	High	10	20.4	86	15.9	1.06
Adult Medium	50x50 L premolar**	High	10	20.4	86	15.73	1.05
Adult Medium	50x50 frontal	Standard	5	20.4	90	7.93	0.53
		High	10	20.4	86	15.65	1.04
Adult Medium	85x93	Standard	5	20.4	90	15.04	1.00
Adult Medium	120x100	Standard	5	20.4	90	16.07	1.07
Adult Medium	85x50*	Standard	5	20.4	90	7.85	0.52

*Only one between Mandibular and Maxillary exam

**For the right side are the same values

CTDI values measured for Adult and Child patient in free-air, for typical conditions of operation, in center position

CTDI_{free air, adult} = 15.04 mGy (FOV 85x93, 90 kV – 5 mA)





CTDI_{free air, child} = 9.68 mGy (FOV 85x93, 66 kV – 6.3 mA)

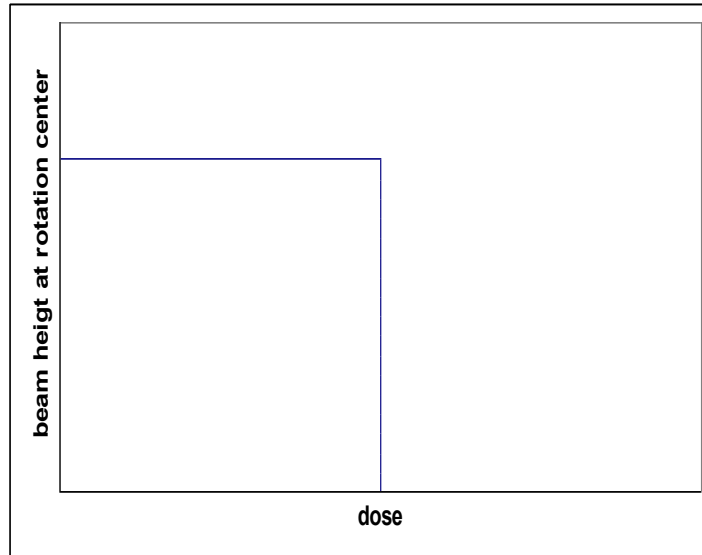

6.8.5 Dose profile

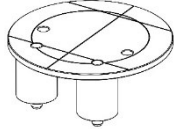
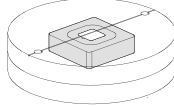
In the following graph the dose profile is displayed along a line z perpendicular to the tomographic plane measured in the center to the Dose Phantom.

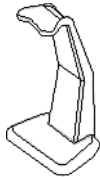

7. REMOVABLE PART LIST

NAME	DESCRIPTION	IMAGES
Centering tool	Dedicated tool to check 2D image quality	
Support Plate	The support plate allows to check the laser alignment and to hold the centering tool	
3D Quality phantom	3D phantom compliant with DIN 6868-161: intended for 3D quality checks.	
Standard Height Chin Support	Standard chin support for panoramic and 3D examination mode. This chin support is marked with "STANDARD HEIGHT" on the front of the support itself.	 
Reduced Height Chin Support	Panoramic and 3D chin support, lower in height, to be used with patients with large shoulders and in all cases where the anatomy of the patient increases the risk of contact with the machine during its rotation. This chin support is marked with "REDUCED HEIGHT" and by a down arrow "▼" on the front of the support itself.	
TMJ Positioner	Specific positioner which allows to perform the open/closed mouth TMJ exam.	

<p>Maxillary-Sinus Chin Support</p>	<p>Dedicated chin support ensuring a perfect coverage of the Maxillary Sinus area.</p>	
<p>Carpus support</p>	<p>Removable hand adapter for Carpus exam</p>	

8. QUALITY ASSURANCE PROGRAM

Here following the list of the operation required to maintain the continued proper functioning of the unit:

Frequency	Type of check	Done by	Reference
Daily	Functioning of the indicator lights	Operator	Paragraph 8.2
Daily	Laser alignment check	Operator	Paragraph 8.3
Monthly	Panoramic image quality check	Operator	Paragraph 8.4.1
Monthly	Cephalometric image quality check	Operator	Paragraph 8.4.2
Six-month	3D image quality check	Operator	Paragraph 8.5
Yearly	Dosimetry test	Authorized personnel	Paragraph 8.6



Note

It is recommended to perform the quality assurance procedures either with the suggested frequency or with the frequency required by local regulations if higher.

8.1 Quality control tools

The following tools² are required to perform the quality check:

- Support plate: used to check laser alignment and to hold the centering tool
- Centering tool: used to check Panoramic image quality
- 3D quality phantom compliant with DIN 6868-161: used to check 3D image quality
- AIS software: used to acquire image and perform measurements
- PhD_C_Test software: used to perform exposure without arm rotation. The PhD_C_Test.exe is located at C:\Program Files (x86)\Acteon Imaging\Panoramic x-mind optima Ceph
- "QC Tool" software: used to assess 3D image quality. The software can be installed through a dedicated setup: a shortcut on the desktop will be created
- kV meter (NOT provided with the unit): used to measure exposure parameters.

All the tools are provided with the unit, except kV meter. The 3D quality phantom is provided as standard with the units for U.S. market. For the other countries, the tool is optional and has to be ordered separately.

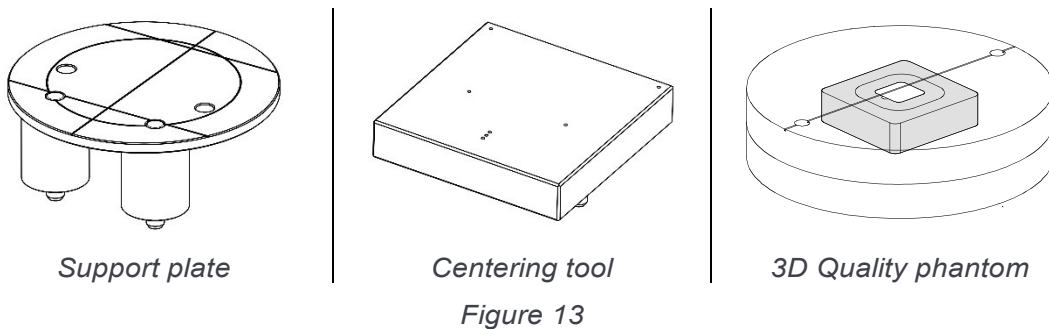

² For removable parts and accessories order codes please refer to the document *XMp Spare Parts and Accessories*

8.2 Functioning of the indicator lights

Power ON the unit, verify that the "Machine Ready" (1), "X-Ray Emission" (2) and "Computer connection" (3) LEDs blink twice.

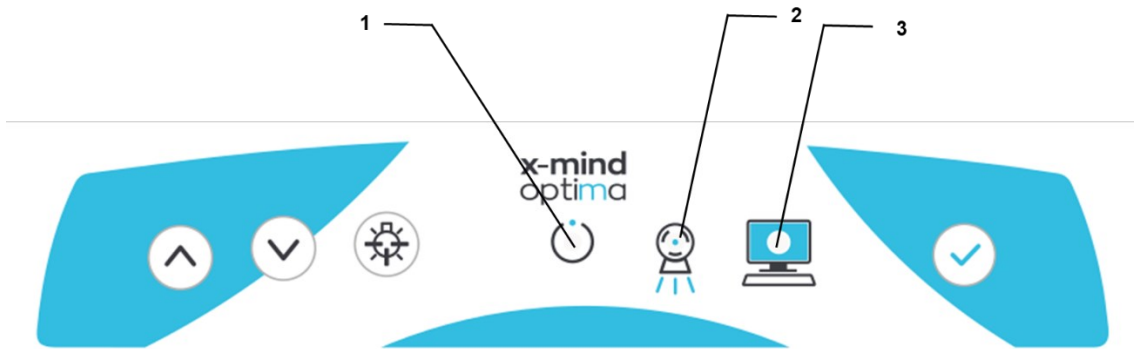

Figure 14

In case the test fails, verify that the main power supply is present in the room. If the case, call technical assistance.

8.3 Laser alignment check

Power ON the unit and perform the axis reset by pressing the >O< button.

At the end of the axis positioning, select standard Panoramic exam (see paragraph 12.1) and press >O<. Place the support plate (Figure 16) on the chin rest support and power ON the laser. Check that the mid-sagittal laser beam is aligned to the reference line of the support plate ($\pm 3\text{mm}$).

At the end of the check, switch OFF the unit.

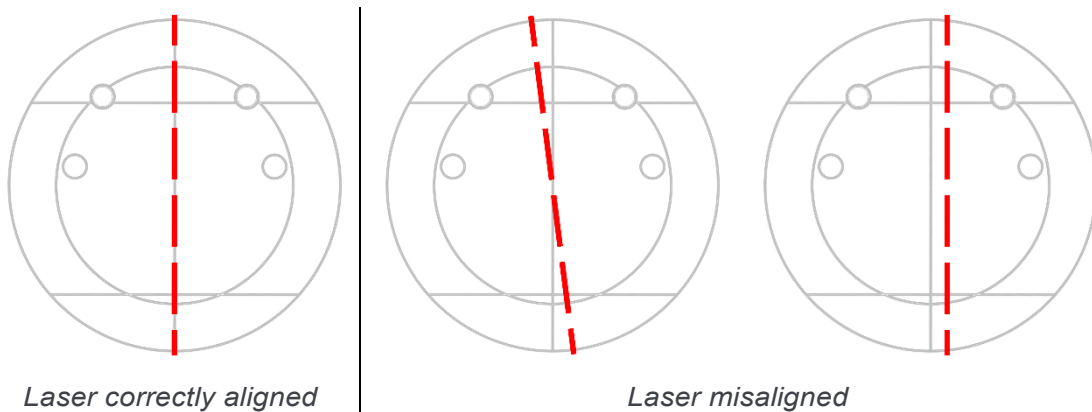

Figure 15

In case the test fails, repeat it checking that there is no mechanical interference. If misalignment is still present, call technical assistance.

8.4 Panoramic and CEPH image quality check



Warning

X-rays will be emitted during the performance of the following operations. It is recommended to use the greatest caution and to comply with local safety regulations and laws.

8.4.1 Panoramic image quality check

1. Switch ON the unit (see paragraph 9.1.1).
2. Open AIS software and open the patient "Quality Test". If not present, create a new patient (Last name: "Quality"; First name: "Test").
3. From the top toolbar, select the Panoramic icon to open the x-mind optima interface.

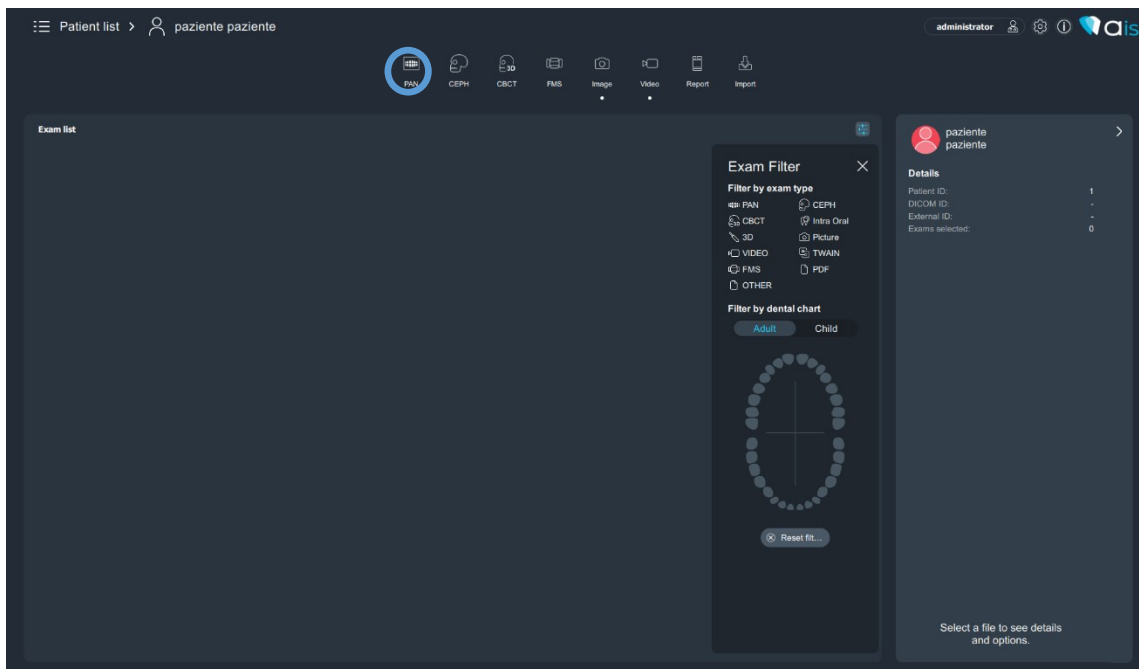

4. Mount the centering tool on the support plate and place it on the chin rest support.

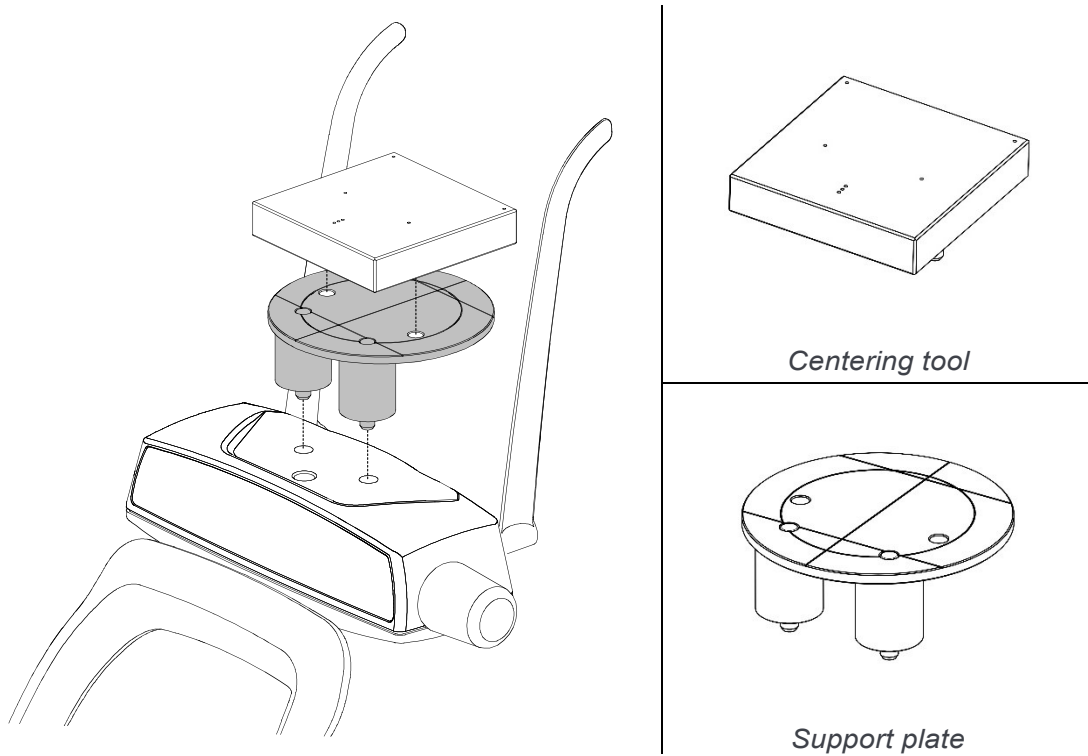
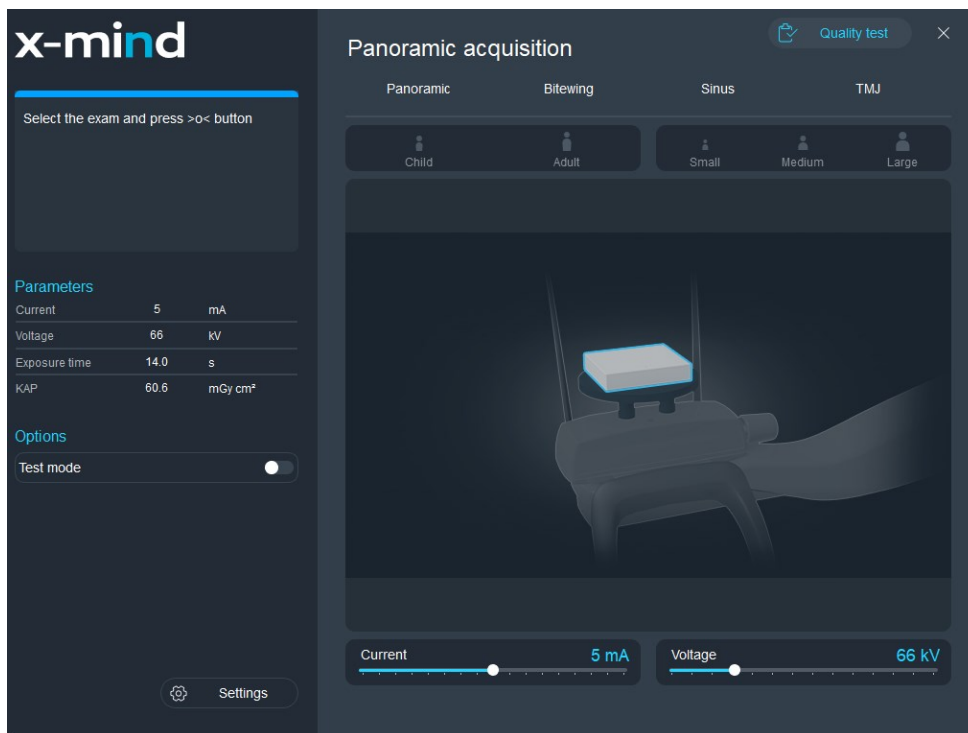

Figure 16: Support plate and centering tool positioning

5. On the main menu of the virtual interface, select "Quality Test" exam, the following image will be displayed:



6. Select "Quality test" exam clicking on the right area of the virtual interface.
7. Make an exposure at 66 kV, 6.3 mA (see chapter 10).
8. Close the x-mind optima interface
9. Double-click to open the acquisition
10. Select the "Measurements" icon and measure the distance between the two external spheres; this value must be $167 \text{ mm} \pm 2 \text{ mm}$.



In case the test fails, call technical assistance.

11. Measure the distance between the left external sphere and the central one and the distance between the right external sphere and the central one: the difference of these values must be maximum 2 mm.
In case the test fails, call technical assistance.
12. Record the tests results in the log book at paragraph 8.4.3.

8.4.2 Cephalometric image quality check (CEPH version only)

1. Follow steps 1 to 3 of the previous paragraph (panoramic image quality check).
2. **Remove** the centering tool from the chin rest (see step 4 of the panoramic image quality check).
3. Open the GUI and select a 18x24 HS latero lateral CEPH exam, set 60 kV, 4 mA, rotate the CEPH head support to the latero lateral position.

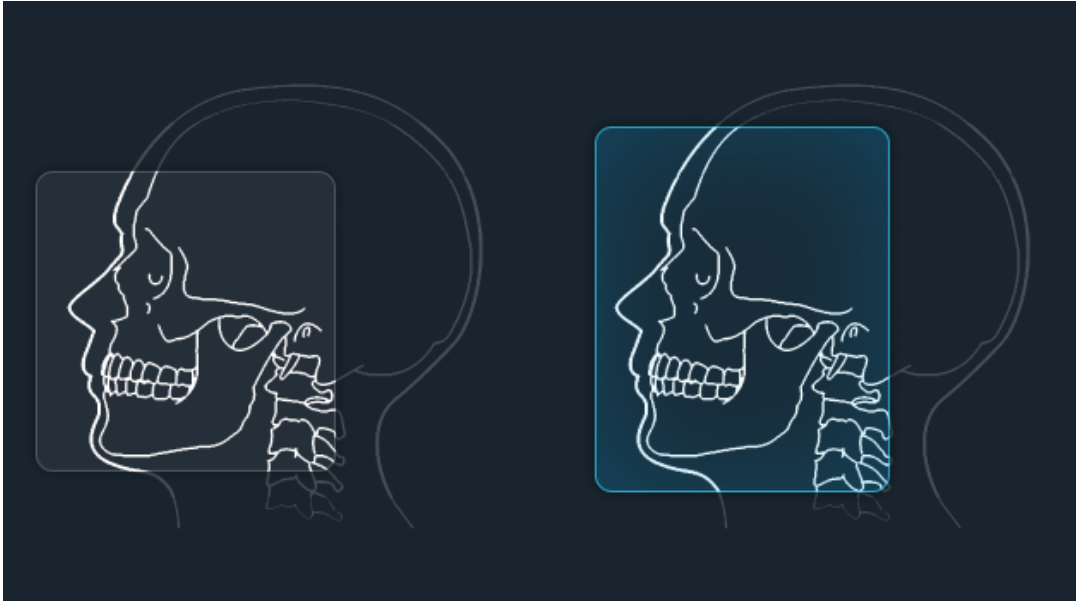

4. Take an exposure.
5. Verify that the image of the small sphere of the ear pin far away from the detector is inside the circle of the ear pin close to the detector.
6. Record the tests results in the log book at paragraph 8.4.3.

8.5 3D image quality check

The 3D image quality check is based on the usage of the 3D quality phantom (or equivalent) and the software "QC tool".

The phantom consists of discs of PMMA with inclusions of different materials (PVC and Air) for performing the required measurements. After the image acquisition, the volume is exported in DICOM format from the imaging program into the "QC tool".

The following paragraphs describe the tests to be performed for 3D image quality test.

8.5.1 "QC Tool" software

The "QC Tool" software can be started either from the desktop shortcut or directly from AIS by right clicking on the acquired 3D test image as described below. After each test, record the measurements in the logbook provided in paragraph 8.5.12. At the end of the test a report can be exported in .pdf and .csv format.

Once the 3D acquisition of the quality phantom is imported in the QC tool, a new test can be started by clicking on "Start Quality Control Test".

In the first page of the QC tool the operator can configure the test, by specifying the following information:

- Device
- Phantom used
- Tester information
- Practitioner information
- Type of test (Acceptance/Constancy)
- Local regulation.

Once the test is set up, it can be started by clicking on "Start test".

The QC tool operator interface is divided in the following areas:



Figure 17

1. Image viewer
2. Slice number
3. Name and description of the current measure
4. Measured value
5. Example image which shows how to perform the measurement
6. Button to proceed/skip to the next measure

At the end of the test, click on "Save test" in order to save the result. The result of past test can be accessed from the main page of the QC tool by clicking on "Past tests". A test report can be generated by clicking on "Export test report". The report will be exported in two file formats: .pdf and .csv.

Record the measurements in the logbook provided at paragraph 8.5.12.



Note

In case you find any value out of the acceptable range, please call your service representative for a equipment inspection.

8.5.2 3D test image acquisition

In order to acquire the 3D image needed for the quality test, create (if not present) a patient “Quality Test” and perform the following steps:

1. On the main menu of the virtual interface, select "Quality Test" exam.
2. Select "3D QC" exam clicking on the right area of the virtual interface.
3. Place the support plate on the chin rest and place the 3D quality phantom on the plate, in such a way as the reference central line is on the top.

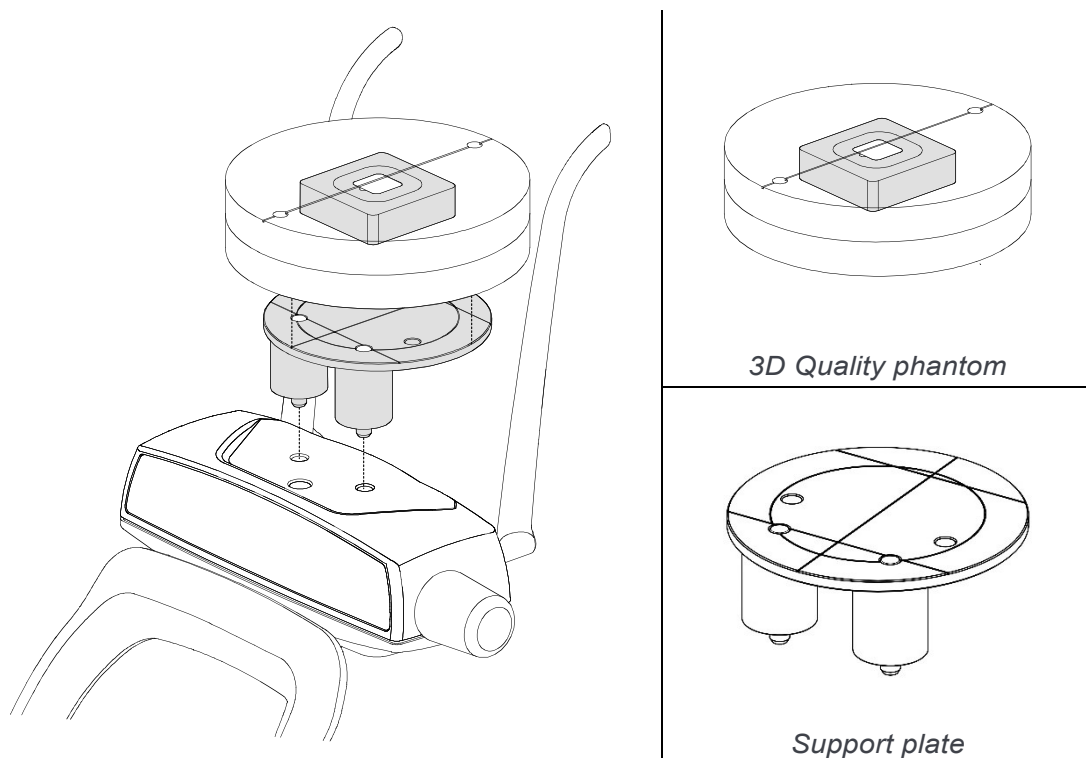

Figure 18

4. On the PVC insertion is present a position reference; this reference must be positioned towards the keyboard side.

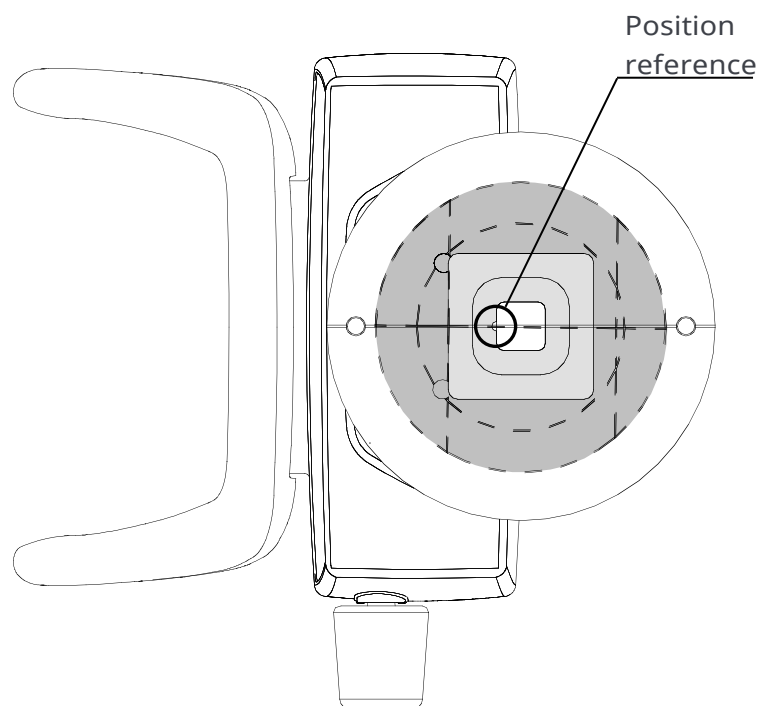

Figure 19

5. Press the button ">O<" on the keyboard to run the chin rest automatic positioning.
6. Switch ON the laser and move the phantom in order to align its reference central line to the sagittal plane; the PVC insertion must be centred inside the internal circle of the support plate.
7. Press the button ">O<" on the keyboard and make an exposure at 84 kV, 5 mA.
8. Right click on the acquired image and select "Export to QC Tool" from the drop-down menu.

8.5.3 Nyquist frequency

Verify that the displayed image looks like the following:

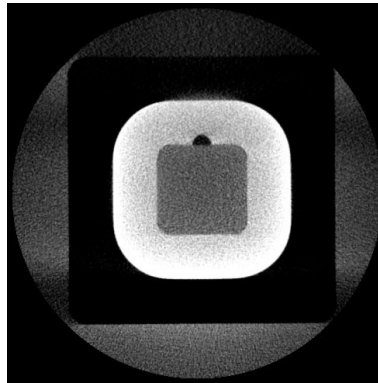

Figure 20

Left click and drag to draw an area as shown in the example picture on the right panel (5 - Figure 17).

Verify that the Nyquist frequency value displayed is greater or equal to 1. Report this value in the "Nyquist frequency" cell of the QC log book at paragraph 8.5.12.

8.5.4 Contrast to noise ratio

Click on "Next measure" button (6 - Figure 17) to proceed with the "Contrast to noise ratio" test, which gives information about noise performances.

The image will be loaded automatically; left click to place an area as shown in the example picture on the right panel (5 - Figure 17).

Two values are displayed:

- Contrast to Noise Ratio: verify that the displayed value is greater or equal to 4. Report this value in the "Image noise" cell of the QC log book at paragraph 8.5.12
- Contrast: verify that the displayed value is greater or equal to 400. Report this value in the "Low contrast resolution" cell of the QC log book at paragraph 8.5.12.

8.5.5 Spatial resolution

Click on "Next measure" button (6 - Figure 17) to proceed with the "Modulation Transfer Function" test, which gives information about spatial resolution. The image will be loaded automatically. Left click to place an area as shown in the sample picture on the right panel (5 - Figure 17). Two values are displayed, which are characteristic points of the Modulation Transfer Function expressed in lp/mm:

- MTF_{10%} - spatial frequency at which the frequency response is 10% of the maximum value. This value must be greater or equal to 1 lp/mm
- MTF_{50%} - spatial frequency at which the frequency response is 50% of the maximum value.

Report the values in the "MTF 10%" and "MTF 50%" cells of the QC log book at paragraph 8.5.12.

The graphical representation of the MTF (referred to the 3D exam of standard adult patient) is reported hereinafter:

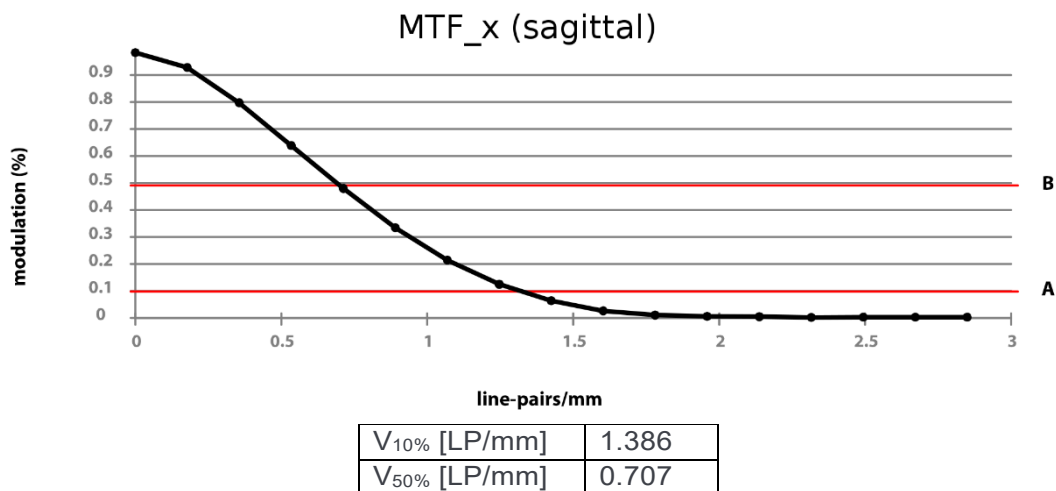

8.5.6 CT number

Click on "Next measure" button (6 - Figure 17) to proceed with the "CT number" test, which gives information about the CT number of the different materials within the volume. The image will be loaded automatically, left click and drag to draw an area as shown in the example picture on the right panel (5 - Figure 17).

The mean and standard deviation of the gray levels inside the area are displayed. The mean value must be in the range from -100 to +100 HU.

Report this value in the "CT number" cell of the QC log book at paragraph 8.5.12.

8.5.7 Length and width measures

Click on "Next measure" button (6 - Figure 17) to proceed with the "Length and width" test, which gives information about the geometry of the 3D reconstruction in the tomographic plane. The image will be loaded automatically, left click and drag to draw an area as shown in the example picture on the right panel (5 - Figure 17). Both measures have to be in the range from 54.0 mm to 66.0 mm (nominal 60 mm). Report these values in the "Length measure" and "Width measure" cells of the QC log book at paragraph 8.5.12.

8.5.8 Slice thickness

Click on "Next measure" button (6 - Figure 17) to proceed with the "Slice thickness" test, which gives information about the geometry of the 3D reconstruction along the z axis. The image will be loaded automatically, left click and drag to draw an area as shown in the example picture on the right panel (5 - Figure 17). Verify that the Slice thickness value displayed is in the range from 15.3 mm to 18.7 mm (nominal 17.0 mm). Report these values in the "Slice thickness" cell of the QC log book at paragraph 8.5.12.

8.5.9 Homogeneity

Click on "Next measure" button (6 - Figure 17) to proceed with the "Homogeneity" test which gives information about the uniformity of the reconstruction. The image will be loaded automatically: verify that the displayed image looks like the following:

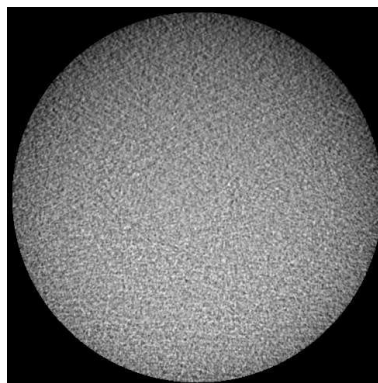

Figure 21

The measurement will be performed automatically. The Homogeneity value must be greater or equal to 5. Report these values in the "Homogeneity" cell of the QC log book at paragraph 8.5.12.

8.5.10 Dose at the isocenter



Note

Perform this test only if required by local regulation.

For this analysis three dose measurements are required. The dose measures must be taken in free air, with the dosimeter as close as possible to the image receptor plane and

the exposure parameters set to Dentition 3D, Adult patient, Medium size. The dose values should be expressed in mGy.

Two values are computed starting from the three dose measures:

- dose at the isocentre: dose computed in the center of rotation, where the patient is, according to the geometry of the machine
- dose maximum aberration: index of the dose reproducibility, expressed as percentage deviation from the mean value.

8.5.11 Acceptance index

In the last section an index is displayed summarizing the quality of the 3D image with respect to the given dose.

It is computed starting from the quality parameters previously measured: Contrast to Noise Ratio, $MTF_{50\%}$ and Dose at the isocentre. The index is expressed in $1/(mGy \cdot cm^2)$.

8.6 Dosimetry test (paragraph for authorised personnel)



Note

The dosimetry test has to be performed only by authorized personnel. The present paragraph explains the procedure for dosimetry test with non-invasive method. For further details, please refer to Service Manual.

1. Place the probe of the dosimeter on the center of the sensor area (black rectangle on the sensor plastic cover).
2. Open the PhD_C_Test software (located at C:\Program Files (x86)\Acteon Imaging\Panoramic x-mind optima CEPH) and check that the unit is connected to the PC (the message "MCU is connected" is displayed in the bottom left corner of the program window).
3. From the "Exam parameters" panel select the ID as "Centring 3D". Select format as "W01 - 86x90 full 3D".

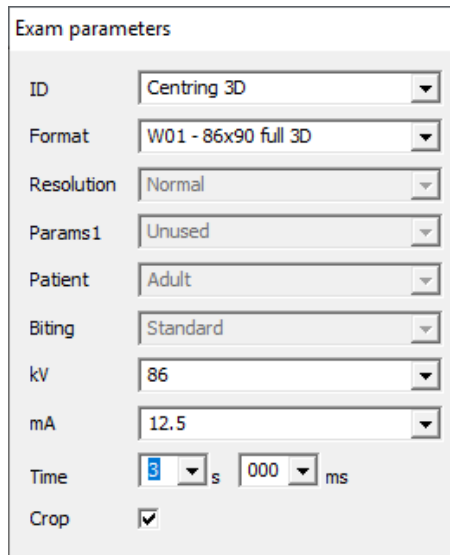

Exam parameters	
ID	Centring 3D
Format	W01 - 86x90 full 3D
Resolution	Normal
Params1	Unused
Patient	Adult
Biting	Standard
kV	86
mA	12.5
Time	3 s 000 ms
Crop	<input checked="" type="checkbox"/>



Note

The "Centring 3D" choice allows you to carry out the dosimetry test without the rotation of the tube-head arm.

- In the "Sensor centring parameters" panel set the following exposure parameters: 60 kV, 2 mA, 3 s.

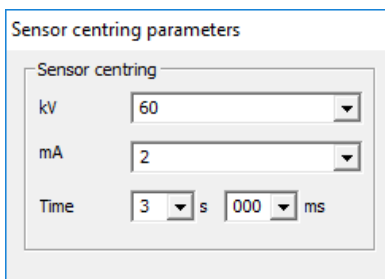

Sensor centring parameters

Sensor centring

kV 60

mA 2

Time 3 s 000 ms

- Press the X-ray button to take an exposure and verify that the measured values are in the acceptance limits listed in the Table at point 6.
- Take a second exposure setting the following parameters: 86 kV, 12.5 mA, 3 s and verify that the measured values are in the acceptance limits listed in the following table.

kV	mA	t (s)	kV acceptance limits	Time acceptance limits
60	2	3	55.2 to 64.8 kV	2.85 to 3.15 s
90	12.5	3	82.8 to 97.2 kV	2.85 to 3.15 s

- In case the test fails (result does not match the indicated values), proceed with the following actions:
 - Check the probe position and repeat the test
 - If the values are still out of range, perform the test using the invasive method as described in the Service Manual
 - If the values are still out of range, call technical assistance.
- Record the test results in the log book at paragraph 8.6.1.

9. GENERAL INSTRUCTIONS FOR USE

9.1 Switching the device ON and OFF



Warning

The unit must be connected to a differential magneto-thermal switch to divide the unit from the supply. This switch must comply the electrical regulations in force in the country of installation.

Minimum requirements at 230 V: working voltage 250 V, current 10 A and differential current 30 mA.

Minimum requirements at 100 V: working voltage 150 V, current 25 A and differential current 30 mA.

9.1.1 Switch-on

1. Before switching on the unit, make sure that the 3D detector is in PAN-3D position (see chapter 10.2.3). If the 3D detector is open in CEPH position, move the rotating arm in the panoramic/3D patient entry position, then close the 3D detector.
2. Press the power switch located on the upper part of the equipment on the operator side to position "1". This will start the "CHECK" function, which is indicated by the LEDs lighting up. When the "CHECK" function is complete, the green LED (3 - Figure 14) on the equipment keyboard starts blinking.
3. Press >O< button on the keyboard to run the equipment axis zero



Warning

During equipment axis zero reset, check that the unit does not collide with external object.

4. Run the "GUI" on the PC and wait for the connection between the PC and equipment; this status is indicated by the blue LED on the equipment (3 - Figure 14) and on the GUI lighting up.

9.1.2 Switch-off

Before switching off the unit, move the 3D detector in PAN-3D position (see chapter 10.2.3).

To switch OFF the unit press the power switch located on the upper part of the equipment on the operator side to position "0". The LEDs will go off.

9.1.3 Emergency button

The equipment has a red emergency button located on the upper part of the unit, near the power switch.

The emergency button only stops the vertical column movement.

In case of an emergency column situation, press the emergency button to stop the movement.

If the column doesn't move, check that the emergency button is not pressed; rotate the button to release it.

9.2 Positioning the chin support

x-mind optima 3D is equipped with different types of removable patient supports:

- a standard height chin support fitted with a bite or a removable appendix for edentulous patients
- a tiniest chin support fitted with a bite or a removable appendix for edentulous patients
- a dedicated support for 2D TMJ exams (Closed/Open mouth).
- a dedicated support for Carpus exam on the CEPH detector.

The standard height chin support must be used on 2D Panoramic, 3D Dentition, Full Arch, Extended Arch, 3D Single Jaw Mandibular and 3D Mandibular Teeth modes, with all patients who can ensure a tight grip on the centring bite. The appendix for edentulous patients must be applied only for patients who cannot ensure a tight grip on the bite or are not co-operating and might move during the exam.

The tiniest chin support can be used with bite or with appendix for edentulous for 3D Maxillary Teeth and 3D Single Jaw Maxillary by following the above criteria; it must be used always with appendix for edentulous for 2D and 3D Sinus and 3D TMJ L/R.

For 2D TMJ exams, a specific positioner is included, allowing the patient to open and close the mouth without touching any positioner with the chin.



Note

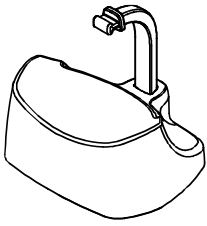
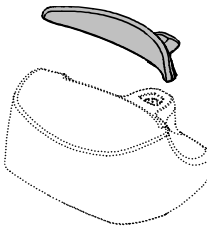
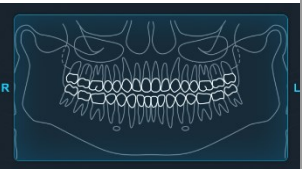
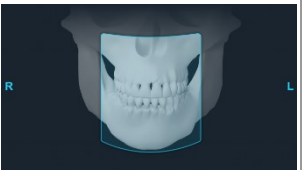
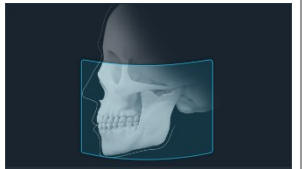
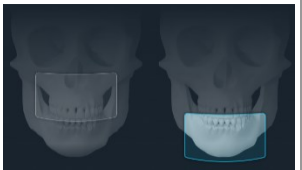

The reduced height chin support, lower in height, should be used in exams with patients with large shoulders and in all cases where the anatomy of the patient increases the risk of contact with the machine during its rotation. This chin support is marked with "REDUCED HEIGHT" and by a down arrow "▼" on the front of the support itself.

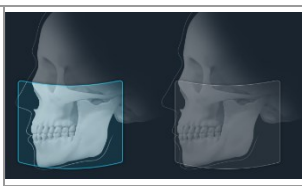
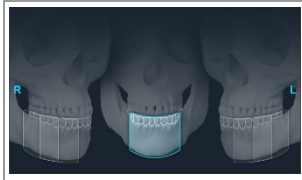
 Standard height chin support 		2D Panoramic & Bitewing
		3D Dentition
		Extended Arch
		3D Single Jaw - Mandibular

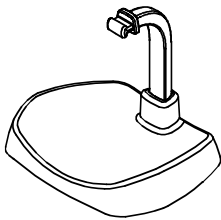
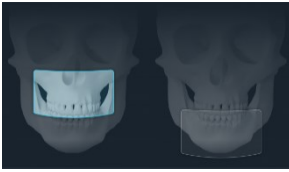
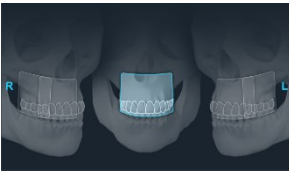
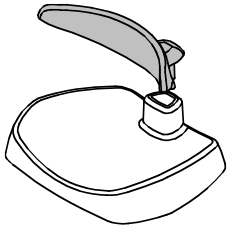
		Full Arch and 100x120 airways
		3D Mandibular Teeth - Frontal / Premolar / Molar

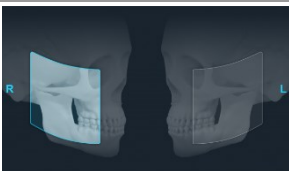
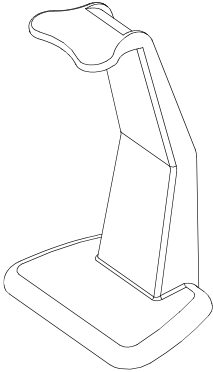
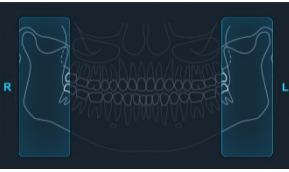
 <p>Thin chin support</p>	 	<p>3D Single Jaw - Maxillary</p> <p>3D Maxillary Teeth - Frontal / Premolar / Molar</p>
 <p>Thin chin support with edentulous patients appendix</p>	  	<p>2D Sinus</p> <p>3D Sinus</p> <p>3D TMJ</p>
 <p>TMJ positioner</p>		<p>2D TMJ C/O</p> <p>2D TMJ Single phase</p>

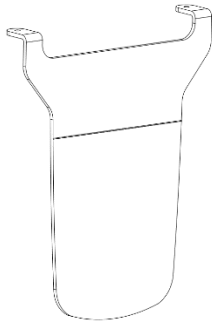

Carpus positioner



Hand support for carpus exam

Temple clamps must be always used to block the patient's head.
For 3D exams, the head strip shall also be used.



Temple clamps

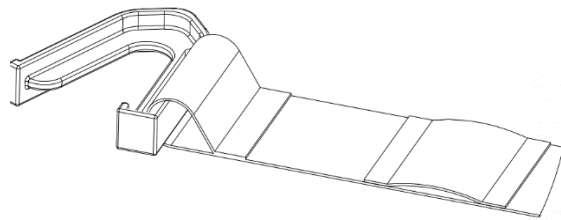

Head strip for 3D exams

9.3 Keyboard - Description and functions

Figure 22 shows a general view of x-mind optima 3D control interface.

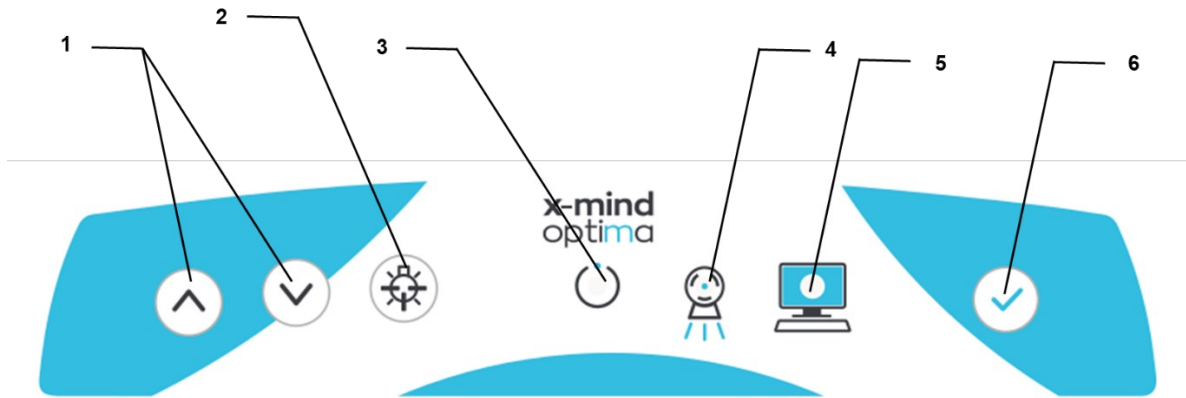









Figure 22 - Keyboard

Label	Description	
1	The up/down movement of the column is controlled by the corresponding keys. The movements are enabled during equipment setting. Column movement is not possible if the emergency button is pressed.	
2	The "Luminous centring device" key turn the laser centring devices ON/OFF, allowing the correct positioning of the patient.	
3	Light indicator of "Machine Ready" status: <ul style="list-style-type: none"> Green fixed, alerts the operator that by pressing the X-ray button, X-ray emission will start Green blinking slowly, indicates that by pressing >O< button, axis reset will start Green blinking fast, indicates the equipment cooling status. 	
4	Light indicator "X-Ray Emission" status. It indicates the emission of X-rays.	

Label	Description	
5	Light indicator of "Computer connection" status: <ul style="list-style-type: none"> • Blue fixed, computer connection established • Blue blinking slowly, waiting for computer connection. No X-ray emission available • Blue blinking fast, the equipment is in error state. Refer to the GUI for error description. 	
6	The "Centring/Patient Entrance" key is used to: <ul style="list-style-type: none"> • Start/Stop the exam procedures • Put the rotation arm in the patient entrance position at the end of the exam. 	
--	Temple clamps closing/release knob.	
--	Chin rest control LED: <ul style="list-style-type: none"> • White fixed, the chin rest is correct for the selected exam • White blinking, the chin rest is not present or not correct for the selected exam 	

9.4 Graphical Operator Interface - Description and functions

All unit configuration is managed via the virtual interface (Figure 23) running on the computer. This interface enables the operator to configure all technical features of the unit, to choose and adjust the exam and radiological parameters.

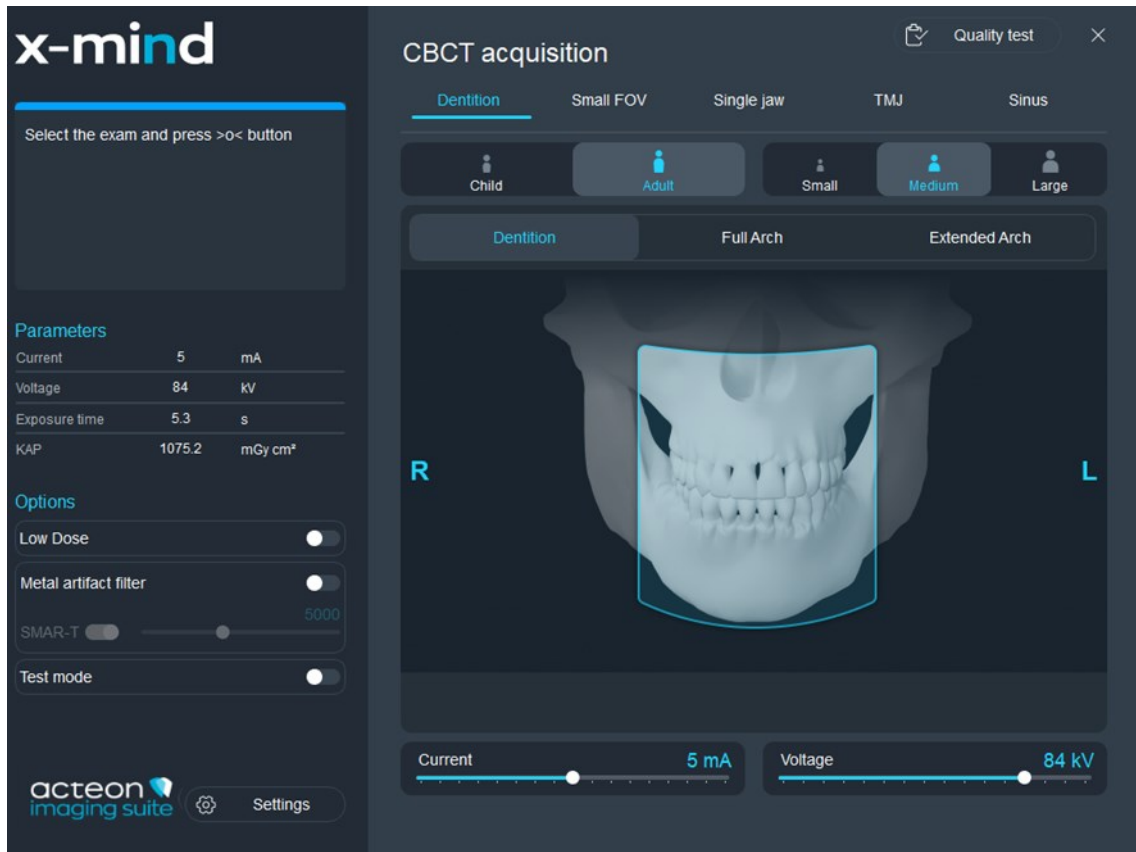
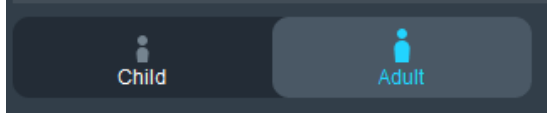
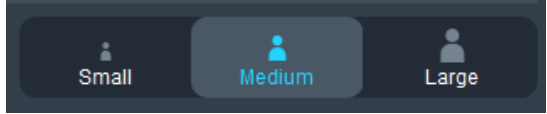
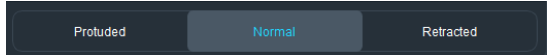
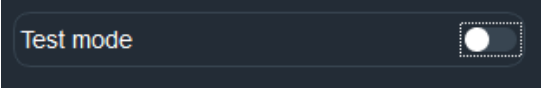
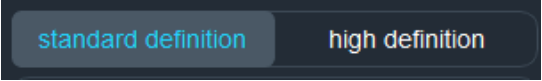



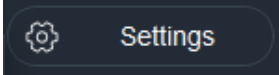

Figure 23

<p>Adult/Child selection: the pre-set exposure values and in panoramic exam the trajectory, are automatically updated based on the current selection (see paragraph 10.3.1)</p>	
<p>Patient size selection: Small/Medium/Large. The pre-set exposure values will be automatically updated based on the current selection (see paragraph 10.3.1).</p>	
<p>Patient's type of biting: Protruded/Normal/ Retracted. This selection is only available in Panoramic mode. The position of the focus layer will be automatically updated based on the current selection.</p>	

<p>Test mode selection: disables X-ray emission. Use the test mode to check for the absence of collision with the patient. Test mode may also be useful when the equipment is used on child patients, to show them how the equipment works before running the exam.</p>	
<p>Resolution mode: for the 3D Maxillary Teeth and 3D Mandibular Teeth exams the operator can choose between standard definition and high definition mode. For the Latero-Lateral projection and Antero-Posterior projection (symmetric) cephalometric exams, the operator can choose between high Definition and high speed mode.</p>	
<p>Low dose: this option sets the default exam parameters to lower ones</p>	
<p>Virtual LED: indicates the current status of the unit: Blue = Initialization Green = Ready Red = Error/waiting for connection Yellow = X-Ray emission</p>	
<p>Exposure parameters selection: changes kV and mA. When the exposure parameters are manually changed, the mode indicator switches from "Pre-set" to "Manual". Return to "Pre-set mode" using the main programme selection key.</p>	
<p>Main menu: selects exam modality, exam type and sub-menu including the available exams.</p>	
<p>Setting: opens the setup menu. This opens the configuration menu where system settings can be managed:</p> <ul style="list-style-type: none"> • Device Information: Display details such as the device model, software package 	

version, firmware versions, unit serial number, and network settings.

- Language Selection: Change the language of the acquisition GUI
- Export unfiltered image: If the option is checked, the output of the acquisition module for 2D exams (PAN and CEPH) will be a raw image with no filter applied. If the option is not checked the operator will be asked to select a postprocessing filter from the acquisition interface. **WARNING:** in this second case the operator will not be able to remove the filter from the image afterward.
- Save DICOM compressed: If this option is selected CBCT exam datasets are saved in a compressed format to save storage space on the disk.
- Gaussian filter: the selector allows to set the strength (from low to high) of the noise reduction filter applied to CBCT exams, or to disable it.

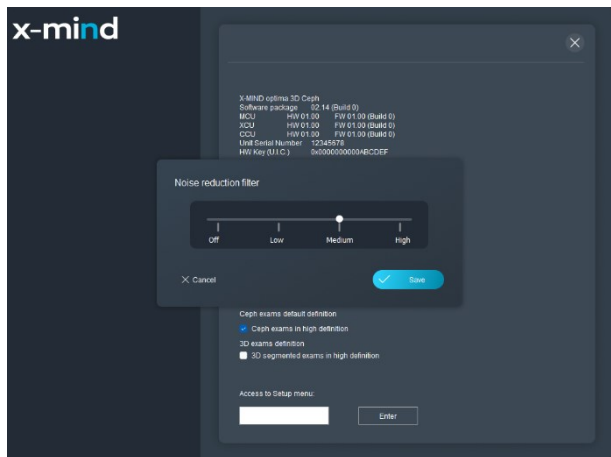
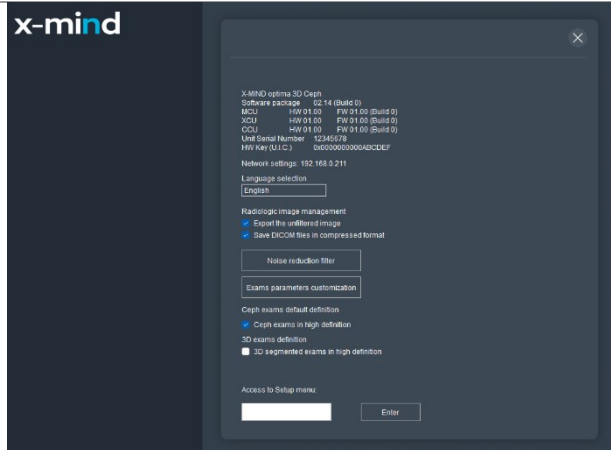

9.4.1 Main GUI area functions

Click on Main Menu to open the exam selection list. After selecting the exam mode (i.e. Panoramic), the operator can choose further options (i.e. Half Panoramic Left).



In the main area of the Virtual Interface the anatomical region matching the current selection is displayed. In case of multiple options available (for instance 3D Single Jaw Maxillary / Mandibular) the final selection can be made by clicking to the corresponding active area on the image.

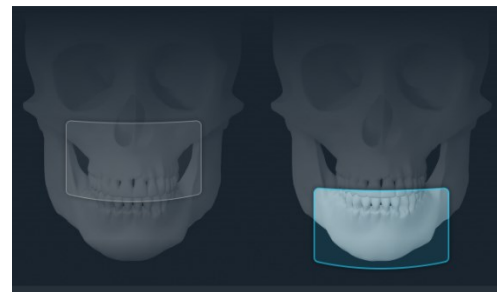

The operator can choose from different options.

- Adult/Child: the correct pre-set exposure values will be automatically loaded. For Panoramic exams with child selection, the exposure values and the trajectory length are reduced
- Patient Size: the correct pre-set exposure values will be automatically loaded
- kV/mA selection: the operator can manually change the exposure parameters
- Resolution mode: HD/XD (when available accordingly with the current selection and only in the models for which is intended)
- Biting mode (when available accordingly with the current selection)
- Scanning of dental impressions and dental models (only in 3D Mandibular Single Jaw and in High Definition mode)
- CEPH Projection and size

A virtual LED indicates the current status of the unit, while a virtual display shows all service messages related to the current status of the unit and possible error messages.

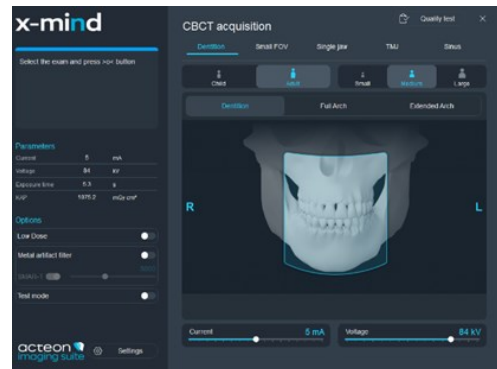

Close to the virtual display there are three different keys that may be selected by the operator: Settings (for opening a service menu), Test mode (enable/disable), Low Dose (enable/disable) and Resolution mode (standard definition / high definition only for the FOVs for which is intended).

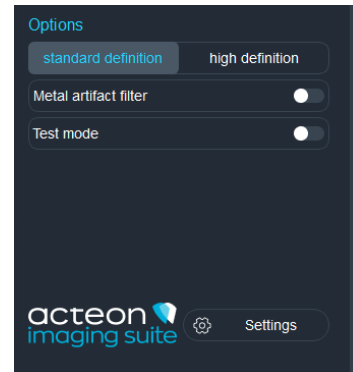

9.5 Digital sensor

x-mind optima 3D is equipped with an CMOS or IGZO flat panel suitable for 2D panoramic and 3D imaging and with a dedicated 2D CMOS detector for cephalometric images.

x-mind optima 3D control equipment checks the consistency of safety measures that allow for correct use of the digital sensor; in particular to prevent acquisition when the image management and processing equipment is not ready to receive the image, it displays the message "Sensor not ready".

10. MAKING AN EXAM

Note



With pediatric patient it is recommended to have a greater attention in taking exams.

In general with child and adolescent patients, before taking the exposure it is suggested to run the exam in test mode in such a way to show the young patient how the unit works and make them feel comfortable.

10.1 Making a panoramic / 3D exam

1. Run the Virtual Interface on the PC clicking on Optima PAN/3D button and wait for the connection between the PC and equipment; this status is indicated by the blue LED lighting up on the keyboard and on the Virtual Interface.
2. Select the exam
3. Select the relevant exam options accordingly with patient characteristics.
4. Press the button ">O<" on the keyboard to run the chin rest automatic positioning accordingly with the current exam selection.
5. The white LED light in the chin support will light ON, fixed in Panoramic, Bitewing and 3D or blinking slowly in other exams.
6. Place the proper chin rest (see paragraph 9.2) or the dental model/dental impression support corresponding to the current exam selection.
7. If the chin rest or support is correct, the white LED is steady on, otherwise it will blink quickly

Note



To go back in the exam selection status to change exam or settings, the proper chin rest of the current exam has to be placed in position, then press >O< to go in start exam position and then, when green led is ON, press >O< again to go back in exam selection status.

8. Position the patient with the help of the lasers then close the temple clamps.
9. Press >O< button to put the equipment in the start exam position; the green LED lights up: the unit is now ready for X-rays.

Note



In the start exam position, the laser light and column movement are not enabled, and on the GUI only kV and mA adjustment is allowed.

Note



Ready for X-ray status is signalled by the green LED on the equipment (3 - Figure 22) and on the GUI lighting up.

Ready for X-ray status remains as long as the equipment is in the start exam position and the GUI is connected to the equipment.

10. Press the X-ray button and keep it pressed as long as the machine is moving

Note



The rotation of the arm and the emission of the X-rays will start with a delay of about 3 seconds from when the X-ray button is pressed.

Warning

Since the X-ray button is a "dead man's switch", its release before the end of the exposure, immediately stops the X-ray emission and the arm rotation. Error 362 or Error 760 will be displayed.

Note

When the "Test" key is selected on the GUI, the Test function is activated. In this condition, it is possible to make the unit carry out all movements made during the exam without emitting X-rays.

Test mode may also be useful when the equipment is used on child patients, to show them how the equipment works before running the exam.

Once the cycle is completed, deactivate the "Test" function by pressing the key again.

11. Once the exposure is completed, the equipment will rotate back to patient exit position. It is now possible to free the patient from the positioning device.
12. Press >O< to return to axis 0 position

Warning

In case of exam interruption, let the patient exit the unit, follow the instruction on the GUI then press >O< to carry out the axis reset.

Warning

During the emission of X-rays, protection procedures for the operator and personnel in the area must comply with local regulations. In all cases, it is recommended that only the patient and operator are present in the room during the emission of X-rays. If the operator is not protected by suitable screens, he must stand at least 2 meters away from the emission of the rays (Figure 1).

Note

x-mind optima 3D assumes that the digital sensor is ready: if this is not the case, the blue light indicator of "Computer connection" status (5 - Figure 22) start blinking slowly. To reset the message on x-mind optima 3D, press "OK" on the GUI and follow the instruction provided (if on the equipment keyboard the green light indicator of "Machine Ready" status is blinking, press >O< to perform the axis reset).



Note

After the exposure, a cooling countdown will be shown on the GUI.
If you try to perform a new exam, before the cooling period has ended, a message indicating the time to wait before performing a new exam will be displayed.
The waiting time allows the anode in the radiogenic tube to cool down.



Warning

After each exam, clean the chin support, the handles and the temple clamps group thoroughly and change the disposable bite protective sleeve.

10.2 Making a cephalometric exam (CEPH version only)

10.2.1 Making a cephalometric exam from panoramic position

1. Run the Virtual Interface on the PC clicking on Optima CEPH button in AIS software and wait for the connection between the PC and equipment; this status is indicated by the blue LED lighting up on the keyboard and on the Virtual Interface.
2. Select the exam
3. Select the relevant exam options accordingly with patient characteristics.
4. Press the button ">O<" on the keyboard the following message will be displayed on the GUI: "CEPH ENTRY STATUS: OPEN FLAT PANEL". The mechanism holding the 3D panel will be unlocked and the 3D detector will move down by a few centimeters (Figure 24-b).



Note

If the 3D panel is not automatically unlocked, press again the button ">O<" and, if the problem still persists, pull-down manually the 3D sensor.

5. Rotate the 3D panel counterclockwise (Figure 24-c) until it locks in place. After one second the equipment will automatically run the axis positioning



Figure 24

6. Position the patient with the help of the Frankfurt reference line on the ear rod and the nasion support (chapter 16).
7. Pressing the button >O<, the CEPH detector and the secondary collimator will move to start exam position and the green LED on the keyboard lights up: the unit is now ready for X-rays.



Note

In the start exam position, the laser light and column movement are not enabled, and on the GUI only kV and mA adjustment is allowed.



Note

Ready for X-ray status is signalled by the green LED on the equipment (3 - Figure 22) and on the GUI lighting up.
Ready for X-ray status remains as long as the equipment is in the start exam position and the GUI is connected to the equipment.

**Note**

Make sure that the “sensor ready” symbol on the CEPH detector lights up in blue  before proceeding.

8. Press the X-ray button and keep it pressed as long as you hear the “beep” sound that indicates that X-ray emission is in progress.

**Note**

The movements of the detector and the emission of the X-rays will start with a delay of about 3 seconds from when the X-ray button is pressed.

**Warning**

Since the X-ray button is a “dead man's switch”, its release before the end of the exposure, immediately stops the X-ray emission and the arm rotation. Error 362 or Error 760 will be displayed.

**Note**

When the “Test” key is selected on the GUI, the Test function is activated. In this condition, it is possible to make the unit carry out all movements made during the exam without emitting X-rays.

Test mode may also be useful when the equipment is used on child patients, to show them how the equipment works before running the exam or to make sure that the moving parts don't hit the patient.

Once the cycle is completed, deactivate the “Test” function by pressing the key again.

9. Once the exposure is completed, the CEPH sensor and secondary collimator will move back to the initial position. It is now possible to free the patient from the positioning device.

**Warning**

In case of exam interruption, let the patient exit the unit, follow the instruction on the GUI then press >O< to carry out the axis reset.

**Warning**

During the emission of X-rays, protection procedures for the operator and personnel in the area must comply with local regulations. In all cases, it is recommended that only the patient and operator are present in the room during the emission of X-rays. If the operator is not protected by suitable screens, he must stand at least 2 meters away from the emission of the rays (Figure 1).

**Note**

x-mind optima 3D assumes that the digital sensor is ready: if this is not the case, the blue light indicator of “Computer connection” status (5 - Figure 22) start blinking slowly. To reset the message on x-mind optima 3D, press “OK” on the GUI and follow the instruction provided (if on the equipment keyboard the green light indicator of “Machine Ready” status is blinking, press >O< to perform the axis reset).

**Note**

After the exposure, a cooling countdown will be shown on the GUI.

If you try to perform a new exam, before the cooling period has ended, a message indicating the time to wait before performing a new exam will be displayed.

The waiting time allows the anode in the radiogenic tube to cool down.

**Warning**

After each exam, clean the nose rest and the temple clamps thoroughly and replace the disposable ear pins protective covers.

10.2.2 Making a new cephalometric exam

1. Run the Virtual Interface on the PC clicking on Optima CEPH button in AIS software
2. Make a new exam selection (or keep the current one).
3. Proceed as above 10.2.1 from point 6.

10.2.3 Going back to panoramic / 3D mode

1. Select a new 2D pan or 3D exam on the GUI then press the button >O< on the keyboard; the following message will be displayed on the GUI: "Close 3D sensor".
2. In order to close the flat panel, rotate it clockwise then push-up: after 1s the equipment will reset the axis position to pan / 3D mode.
3. Proceed as above 10.1 from point 3.

10.3 Pre-set / Manual exposure



Note

If the previous exam was carried out manually, press the "Size Selection" key to return to pre-set mode.

After setting the equipment, the following two operating modes may be chosen:

- PRE-SET: with the kV and mA values programmed on the basis of the type of patient and size.
- MANUAL: with the possibility to vary the kV and mA values already set.



Note

The exam parameters set as the default are values to be taken as the starting point. Operators can optimise the parameters according to their needs.

10.3.1 Pre-set exposure

Select the type of patient with the Adult/Child¹ icons, according to the following table. If child option is selected, exposure parameters are lower respect to the corresponding adult programs. In addition, the exam trajectory in panoramic programs is reduced of about 10% and of another 15% due to the child collimator (*).

Select the type of build with the Size icons (Small - Medium - Large)² according to the following table. On the basis of these selections, the display will show the kV and mA settings accordingly.

Select the type of biting with the icon "Type of Biting Selection" (option available in Panoramic mode only).

() this feature is active by default, but the operator can disable it and in that case the X-ray beam size is the same as in adult selection*

Suggested size selection according to the patient weight:

Child	
For child patients up to 12-year-old	
Small	< 30 kg (< 66 lb)
Medium	30 to 45 kg (66 to 99 lb)
Large	> 45 kg (> 99 lb)

Adult	
For adolescent (greater than 12 through 21-year-old) and adult patients	
Small	< 70 kg (< 154 lb)
Medium	70 to 100 kg (154 to 220 lb)
Large	> 100 kg (> 220 lb)

¹ Adult/Child definition is related to the age according to the FDA's guidance "Premarket Assessment of Pediatric Medical Devices", Table 1 – Age Ranges of Pediatric Subgroups.

² According to the report "Fryar CD, Gu Q, Ogden CL, Flegal KM. Anthropometric reference data for children and adults: United States, 2011–2014. National Center for Health Statistics. Vital Health Stat 3(39). 2016", the size definition is based on the identification of three percentile ranges of the population weight distribution:

- Child: Small (<25th), Medium (25th to 75th), Large (>75th)
- Adult: Small (<15th), Medium (15th to 75th), Large (>75th), referred to the adult male weight distribution. Corresponding female ranges: Small (<50th), Medium (50th to 90th), Large (>90th).

Based on these grouping, the weight ranges are derived from Table 1 for child (choosing a representative patient of 10-year-old and rounding up male-female average weights, from Table 5 for adult male and Table 3 for adult female).

Exposure values in 2D Panoramic modes

	Adult Patient (14 seconds)		Child Patient (12.8 seconds)	
	kV	mA	kV	mA
Small	76	9	66	8
Medium	80	9	68	8
Large	82	9	70	8

Exposure values in 2D Sinus mode

	Adult Patient (9 seconds)		Child Patient (9 seconds)	
	kV	mA	kV	mA
Small	68	8	64	8
Medium	72	8	66	8
Large	74	8	68	8

Exposure values in 2D TMJ mode

	Adult Patient (10.6 seconds)		Child Patient (10.6 seconds)	
	kV	mA	kV	mA
Small	70	8	64	8
Medium	74	8	66	8
Large	78	8	68	8

Exposure values in 3D Dentition, Full Arch, Extended Arch and 100x120 airways

	Adult Patient (5.3 seconds)		Child Patient (5.3 seconds)	
	kV	mA	kV	mA
Small	84	4	64	6.3
Medium	90	5	66	6.3
Large	90	6.3	68	6.3

Exposure values in 3D Single Jaw, 3D Maxillary and Mandibular Teeth modes standard definition mode

	Adult Patient (5.3 seconds)		Child Patient (5.3 seconds)	
	kV	mA	kV	mA
Small	84	4	64	6.3
Medium	84	5	66	6.3
Large	84	6	68	6.3

Exposure values in 3D Maxillary and Mandibular Teeth modes high definition mode (only in the models for which is intended)

	Adult Patient (5.3 seconds)		Child Patient (5.3 seconds)	
	kV	mA	kV	mA
Small	84	8	64	8
Medium	86	10	66	8
Large	90	12.5	68	8

Exposure values in 3D TMJ mode

	Adult Patient (5 seconds)		Child Patient (5 seconds)	
	kV	mA	kV	mA
Small	82	5	64	6.3
Medium	82	6	66	6.3
Large	82	7	68	6.3

Exposure values in 3D Sinus mode

	Adult Patient (5.3 seconds)		Child Patient (5.3 seconds)	
	kV	mA	kV	mA
Small	78	8	64	6.3
Medium	78	9	66	6.3
Large	78	10	68	6.3

Exposure values in CEPH LL mode (CEPH version only)

	Adult Patient (from 4.4 to 15.1 seconds)		Child Patient (from 4.4 to 15.1 seconds)	
	kV	mA	kV	mA
Small	74	8	72	7.1
Medium	76	8	74	7.1
Large	78	8	76	7.1

Exposure values in CEPH AP mode (CEPH version only)

	Adult Patient (5.8 or 12.1 seconds)		Child Patient (5.8 or 12.1 seconds)	
	kV	mA	kV	mA
Small	76	12.5	74	11
Medium	78	12.5	76	11
Large	82	12.5	78	11

Exposure values in Carpus mode (CEPH version only)

	Child Patient (4.4 seconds)	
	kV	mA
Small	62	8
Medium	62	8
Large	62	8

**Note**

The preset exposure parameters are meant to guide the operator through the setting of the different exams. However, the operator can optimise the parameters according to his needs.

**Note**

The type of biting does not affect the kV and mA values, but it affects the position of the focus layer, by adapting rotation movement to the patient's anatomy.

**Note**

All the exposure values are related to the standard dose mode.

10.3.2 Manual exposure

If the pre-set kV and mA pairs are not considered suitable for a specific exam, new parameters can be set in manual mode.

To modify the kV or mA values, press any of the up or down cursors of the KV or mA parameters.

A parameter can be modified by pressing the increase key and the decrease key of the parameter repeatedly.

The kV value can vary between 60 and 90 kV, with 2 kV steps.

The mA value can vary between 2 and 12.5 mA according to the R20 scale.

11. 2D IMAGE PROCESSING

Starting from AIS 5.1 version, it is possible to set the filters directly on AIS GUI if the following item of Setting menu is flagged:

Export the unfiltered image

In this case a default image processing is applied to the exam but it is possible to edit and modify the processing through AIS:

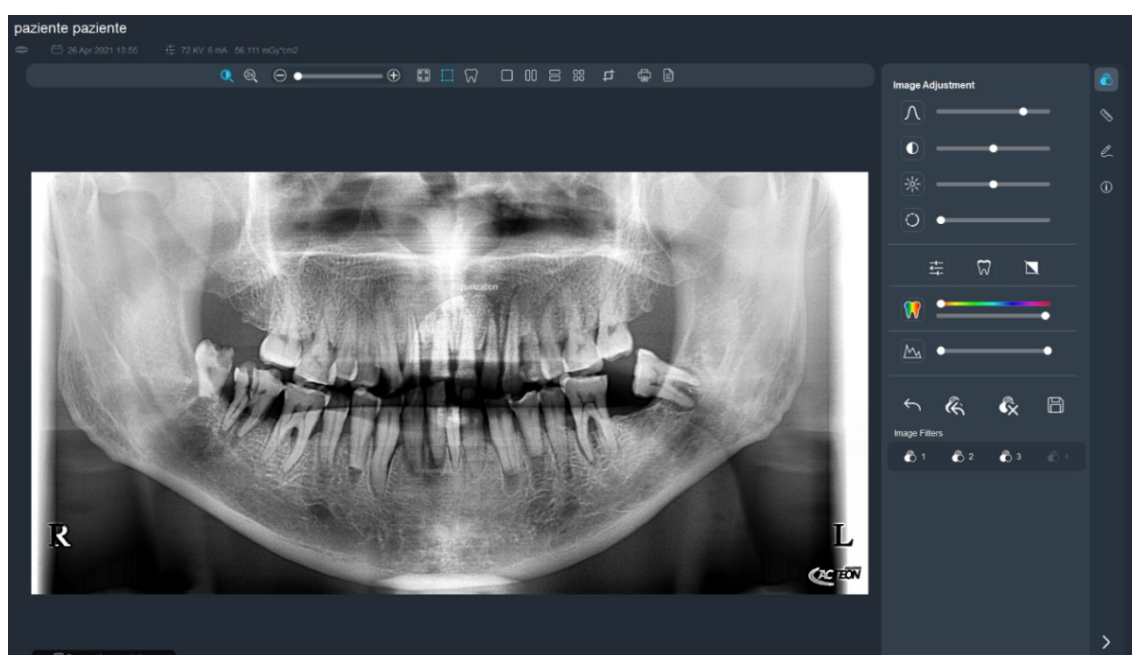

Figure 25

The Image Processing window is composed by three main area (Figure 25):

1. Filters area
2. Toolbars area allowing the filter customization
3. Image preview area displaying the current post-processing

If *Export unfiltered image* item is unflagged the following preview is displayed at the end of the acquisition and by clicking on Adjust the Image Processing menu will be displayed.

By clicking Close the image will be saved into the patient folder.

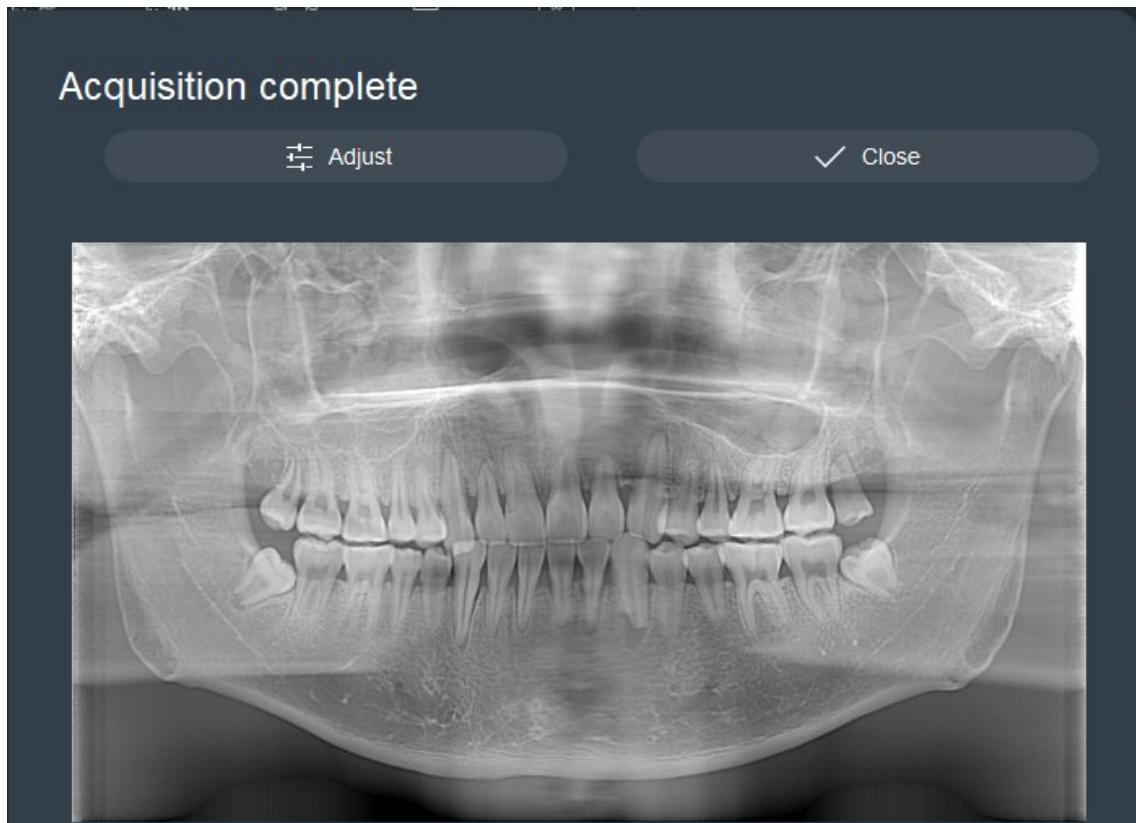

Figure 26

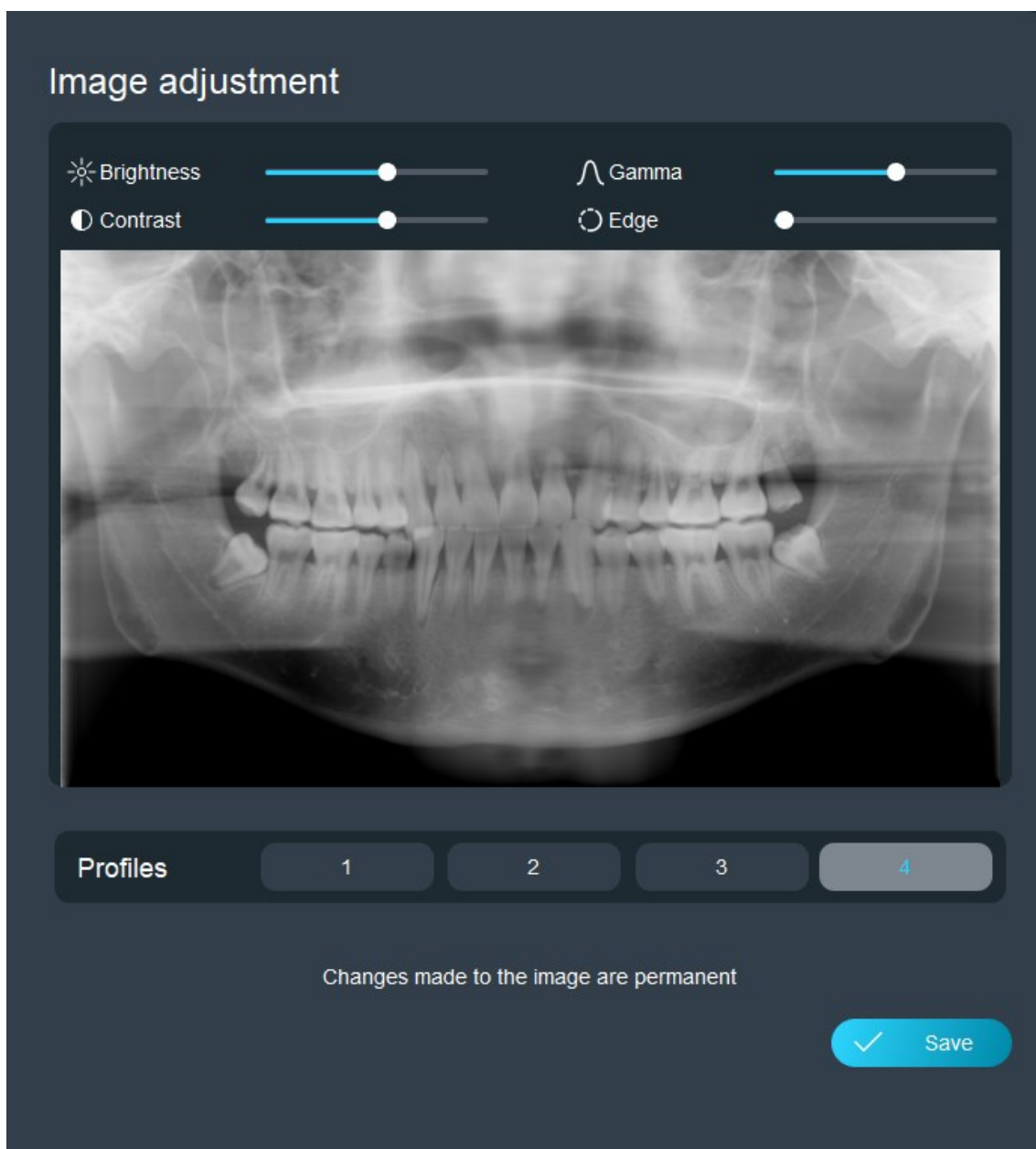

Figure 27

Buttons from 1 to 3 implement pre-set filters. Clicking the button, the corresponding filter will be applied and the preview displayed. Clicking the button 4 the default post-processing can be modified through dedicated toolbars, from the top respectively:

- brightness
- contrast
- gamma value
- image enhancement.

The button Save will apply the current setting to the corresponding button and will set the filter as default in acquisition (Figure 27).

The button 4 is set as default to load the original image (without post-processing) and it can be fully customized as above described.

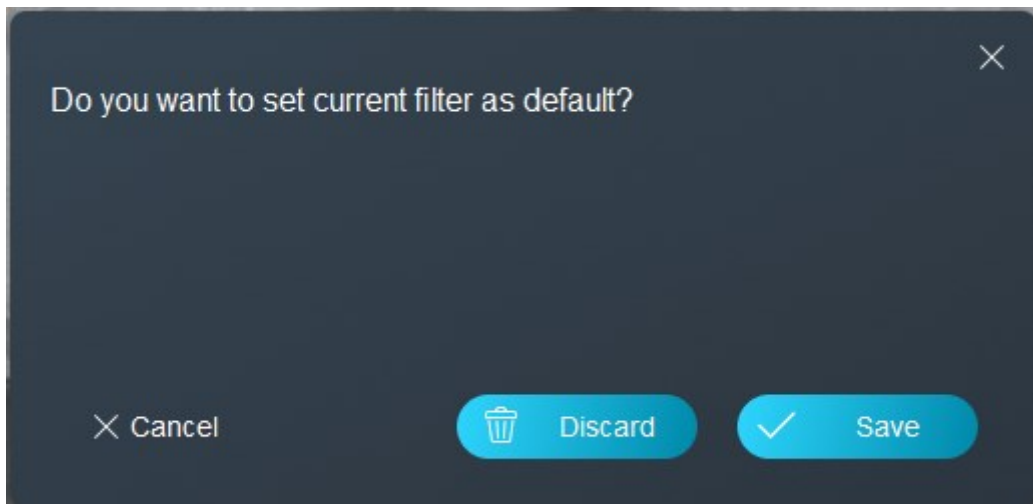

Figure 28

12. 2D EXAMS



Note

The exam parameters set as the default are values to be taken as the starting point. Operators can optimize the parameters according to their needs.



Note

x-mind optima 3D is based on a standard dentition and ascending rami shape. This shape, based on statistical studies, establishes a form for the dentomaxillofacial complex, adopted as "standard". x-mind optima 3D follows a rototranslation path which maintains the magnification factor as stated in the Technical Characteristics of each type of exam as constant along this "standard" shape and in the dentition area. The patient's anatomy can differ significantly from the statistical model, so the magnification factor is not maintained and can be different from the value stated. Based on his experience and competence, the operator has to judge this variation.

IN ANY CASE, RADIOGRAPHY IMAGES CANNOT BE USED TO PERFORM CALCULATIONS OF DISTANCES, ANGLES ETC. ON THE IMAGE



Warning

The measurement of lengths on digital images depends on the specific length calibration of the program used.

It is therefore very important to check the length calibration of the program. To obtain accurate measurements of the anatomical part, verify or perform a spatial calibration of the software ruler: display a Standard Panoramic exam and use the graphical element in the bottom right corner (see red arrow), which is exactly 20 mm in height, to check or calibrate the linear measurement tool.

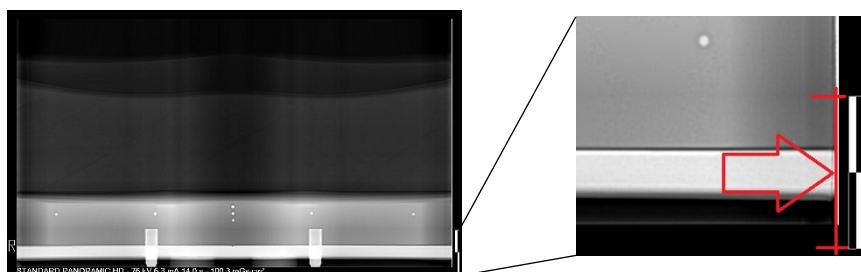

Note

During panoramic exams, the value of the exposure parameters varies according to a fixed curve, to compensate for variations in absorption by the patient's tissues. In this way, it is possible to obtain a good uniformity of the image contrast. In particular, the chosen value of the kV is lowered in the initial and end sections of the panoramic exam and increased in the incisors/canine zone.

The tube current varies according to the kV, also if the set value is slightly increased on the initial/end sections. These variations have the effect of compensating for greater X-ray absorption in the spinal column area. As an example, the variation of the parameters follows the curve below:

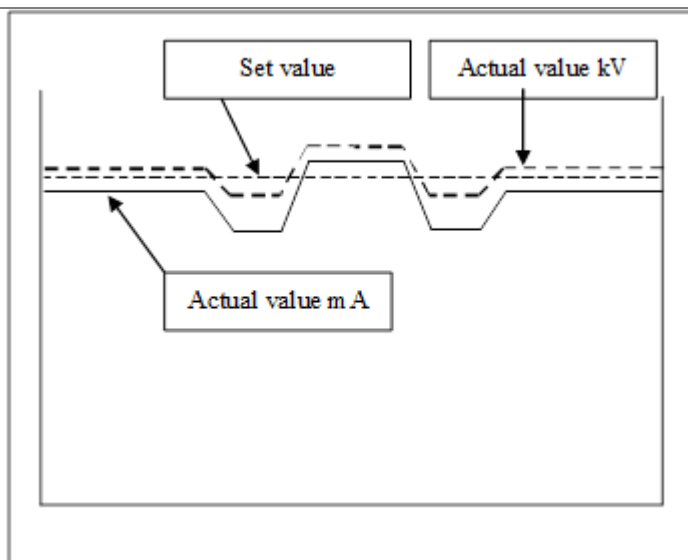

The values displayed during the panoramic exam correspond to the ones chosen by the operator, while the real value in the various positions of the X-ray cycle can be different; in any case, the equipment guarantees that the accuracy of the exposure parameters is always within the limits set by IEC 60601-1 international standards for the safety of medical devices. In particular, in accordance EN with 60601-2-63, the maximum deviation (including the correction according to the above curve and instrumental doubt) is within $\pm 10\%$ for the kV, while for the tube current it is within $\pm 15\%$.

12.1 Standard Panoramic

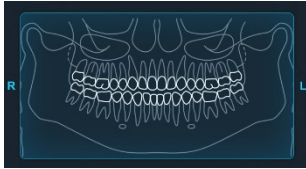

When the unit is switched ON, Panoramic exam mode is selected as standard. If the operator has previously carried out another kind of exam, use the main window in extended view to select Panoramic mode

12.2 Left / Right Half Panoramic

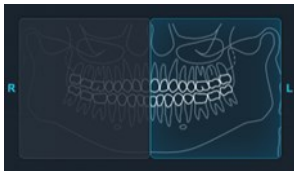

The Half Panoramic mode, right or left, means that only the corresponding half arch is irradiated; emission will start from the beginning, to just after the mid sagittal plane for the right part. For the left, it will start just before the mid sagittal plane and continue until the end of the rotation.

These two kinds of exams are normally used when it is already known that the patient has a problem on only one half of the arch, so it is possible to reduce patient irradiation. Follow the instructions for normal panoramic exams for patient positioning.

12.3 Frontal dentition

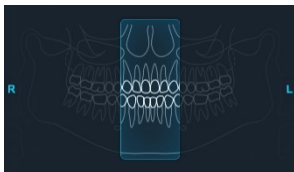

The Frontal dentition exam takes an X-ray of the frontal dentition area (roughly from canine to canine). Follow the instructions for normal panoramic exams for patient positioning.

12.4 Low dose Panoramic

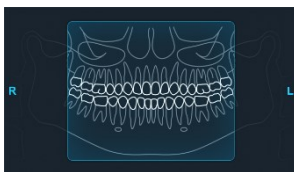

The low dose panoramic exam takes an X-ray only of the dental arch, excluding the ascending rami of the temporomandibular joint from the image; the exam is performed with the same trajectory of the standard Panoramic exam, reducing the rays' emission time.

This exam is used, for instance, during treatment continuation phases or where a lack of pathologies of the same joint is already known.

Follow the instructions for normal panoramic exams for patient positioning.

12.5 Ortho Rad dentition

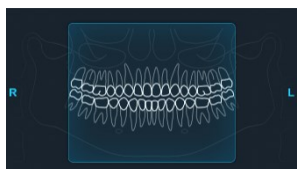

The ortho rad panoramic exam delivers an image of the pure dental arch, excluding the ascending rami branches of the temporo-mandibular joint from the image; the trajectory of the rotating arms is, however, optimized for a better orthogonality between the X-ray beam and incident sections of near teeth. Thus the image has reduced teeth overlapping, improving the diagnosis of interproximal decay.

As a consequence of the different trajectory, the focus layer, mainly in the front teeth area, is smaller and patient positioning for this exam needs more care. Follow the instructions for normal panoramic exams for patient positioning.

12.6 Single Phase Bitewing (L/R)

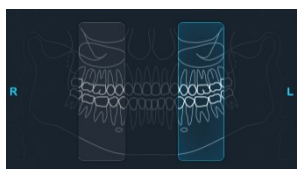

The bitewing mode, right or left, means that only the corresponding bite sector is irradiated; the emission will start from the beginning, to just after the mid sagittal plane for the right part. For the left, it will start just before the mid sagittal plane and continue until the end of the rotation. The exam is performed with the same trajectory of the standard panoramic exam, reducing the rays' emission time.

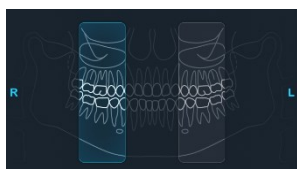

This exam is normally when it is already known that the patient has a problem on one side of the bite-sectors of the arch, so it is possible to reduce patient irradiation.

Follow the instructions for normal panoramic for patient positioning.

12.7 Bilateral Bitewing

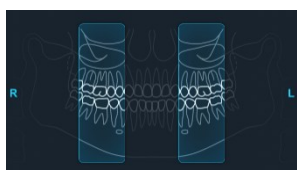

The bilateral Bitewing mode, right and left, means that the two bite-sectors are irradiated; the exam is performed with the same trajectory of the standard panoramic exam, reducing the rays' emission time.

This exam is normally used when it is already known that the patient has a problem on the bite-sectors of the arch, so it is possible to reduce patient irradiation.

Follow the instructions for normal panoramic for patient positioning.

12.8 TMJ C/O

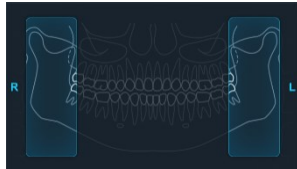

The TMJ Standard function makes it possible to obtain 4 different acquisitions on the same image, by performing two rotational movements. The 4 images represent the right and left condyle of the temporo-mandibular arch (TMJ) with closed mouth and open mouth.

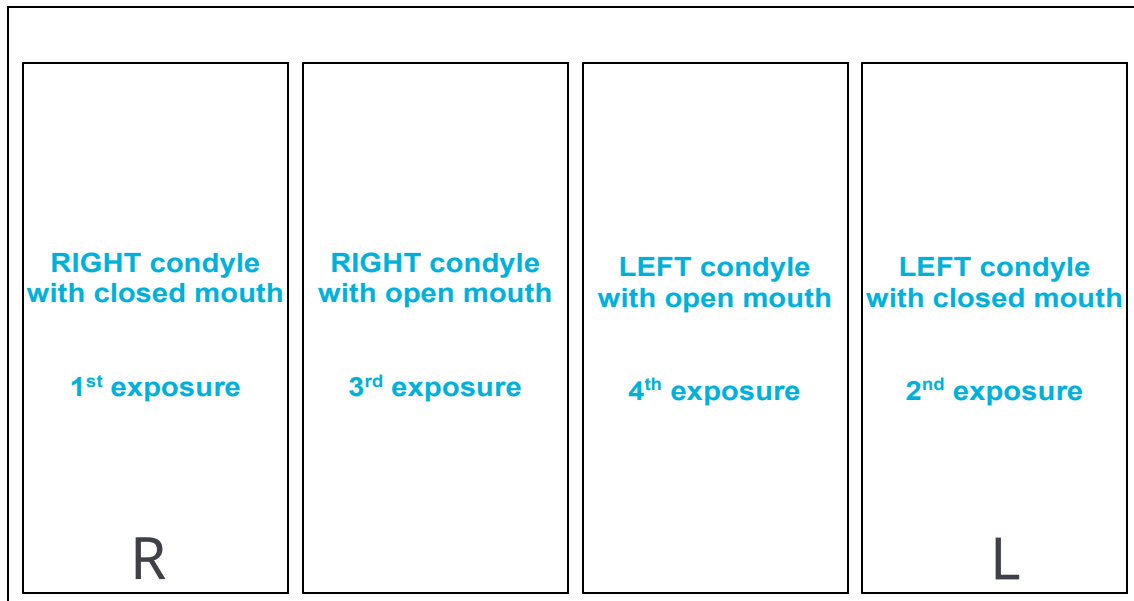
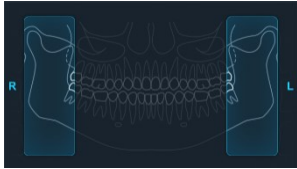

Figure 29: TMJ Closed/Open mouth

12.9 TMJ Single Phase



A single acquisition is made to obtain 2 images representing the right and left condyle of the temporo-mandibular arch (TMJ) with closed mouth or open mouth.

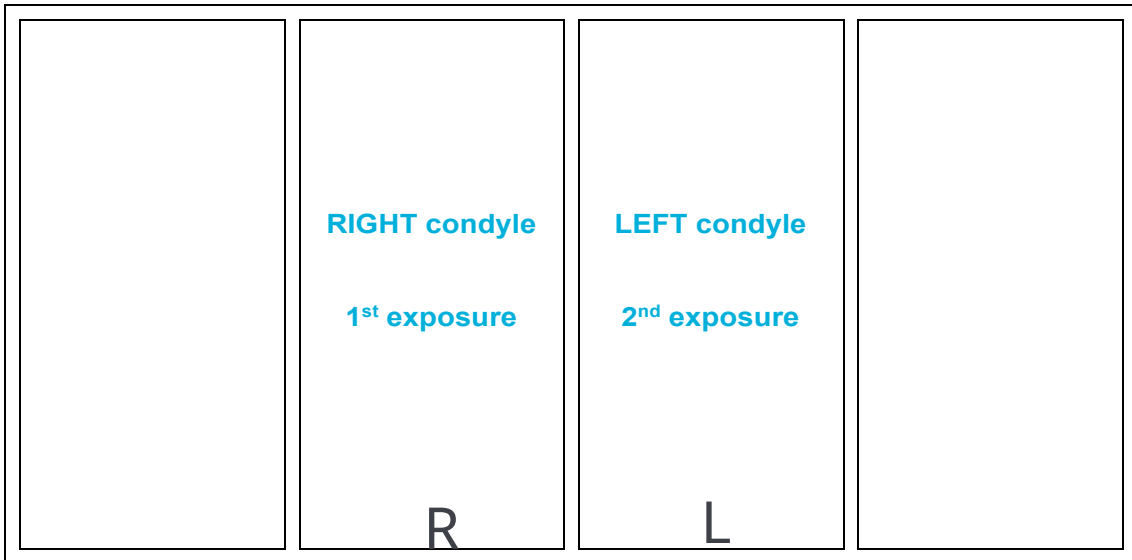
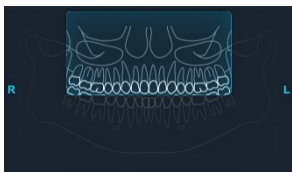

Figure 30: TMJ Single phase

12.10 Sinus



The image is taken on the maxillary sinus area.

13. 3D EXAMS



Note

Especially with pediatric patients evaluate the opportunity to select a smaller Field Of View in order to reduce the dose delivered to the patient.

13.1 3D Dentition

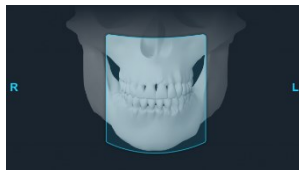

The acquired volume is an 85x93 mm FOV centered to the patient dentition.

13.2 3D Single Jaw and Dental Impression / Dental model scan

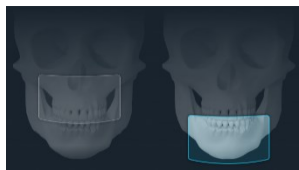

The acquired volume is an 85x50 mm FOV centered either on the maxillary or mandibular arch, depending on the operator selection. One acquisition mode is available: Standard Definition (161 μ m voxel size) for a standard resolution 3D acquisition.

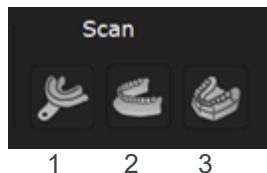

In 3D Mandibular Single Jaw selection the following dental impression/dental model scan programs are available:

1. Dental impression
2. Cast scan (setting for surgical guide)
3. Plaster model

To perform the scan program, place the support plate on the chin rest and place the dental impression/dental model in the center of the plate:

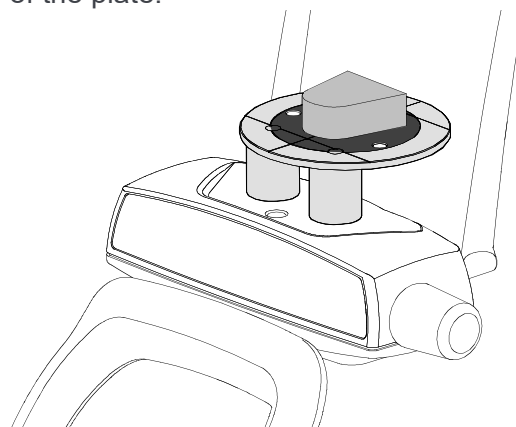
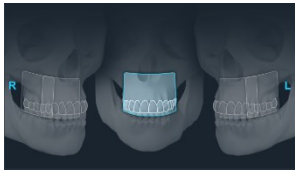

Figure 31

13.3 3D Maxillary Teeth



The acquired volume is a 50 x 50 mm FOV centered on five different positions along the maxillary arch, depending on the operator selection. Two acquisition modes are available: Standard Definition (161 μm voxel size) for a standard resolution 3D acquisition, and High Definition (70 μm voxel size) for the enhancement of the finest details.

13.4 3D Mandibular Teeth

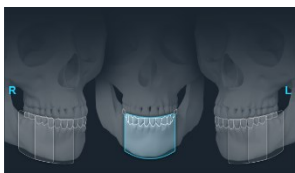

The acquired volume is a 50 x 50 mm FOV centered on five different positions along the mandibular arch, depending on the operator selection. Two acquisition modes are available: Standard Definition (161 μm voxel size) for a standard resolution 3D acquisition, and High Definition (70 μm voxel size) for the enhancement of the finest details.

13.5 Full Arch / 100x120 airways



The acquired volume is a 120x104 mm FOV either centered on the patient dentition or back shifted towards the upper respiratory tract.

13.6 Extended Arch

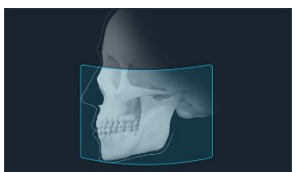

The acquired volume is a 170x120 mm FOV aimed to acquire a larger portion of the maxillofacial region.

This functionality is an option and must be activated following the procedure described in paragraph 8.5 of the service manual.



Warning

The portion of image volume in the "extended" area is reconstructed using a partial set of projections. Compared to the central part of the volume, such image portion can have lower definition in the anatomical details. Refer to Figure 3 for information regarding the shape of the Extended Arch FOV.

13.7 3D TMJ

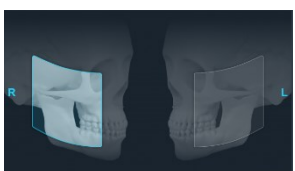

The acquired volume is an 85x90 mm FOV centered to the temporo mandibular joint right or left, accordingly with the operator selection.

13.8 3D SINUS



The acquired volume is an 85x90 mm FOV centered to the maxillary sinus region.

13.9 Metal Artefact Reduction (MAR) filter

A MAR (Metal Artefact Reduction) option can be either activated or deactivated from the Setting page of the GUI. If active, a specific filter for compensating metal artefacts will be applied during the exam reconstruction. The filter can be set with an automatic threshold (SMAR-T) or with a manual threshold that can be tuned with the slider.

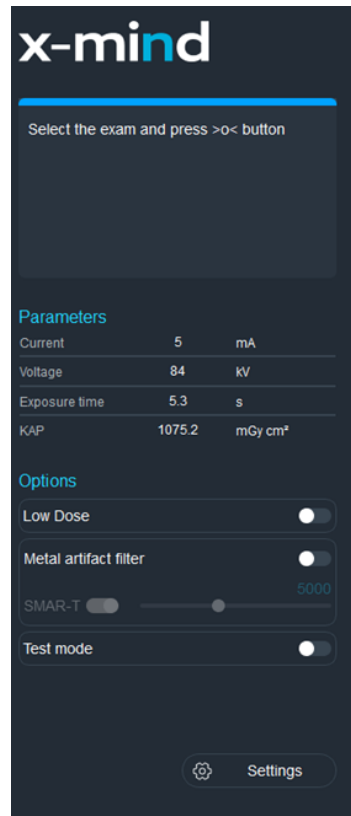
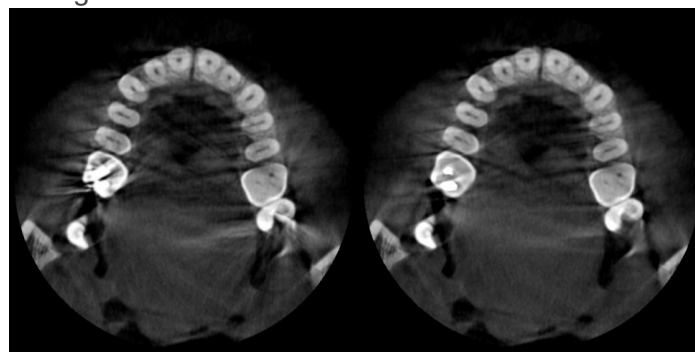

Figure 32

The same filter may be also applied/removed retroactively at any time through the option “New Reconstruction” available for exams already archived to the database.

Note

MAR-processed images should be always compared with the original unprocessed images.



Non-processed image

MAR-processed image

Figure 33

13.10 New reconstruction

To run a new reconstruction of a 3D study, select its icon inside the exam list of the patient folder and right click on it. Then select "New Reconstruction".

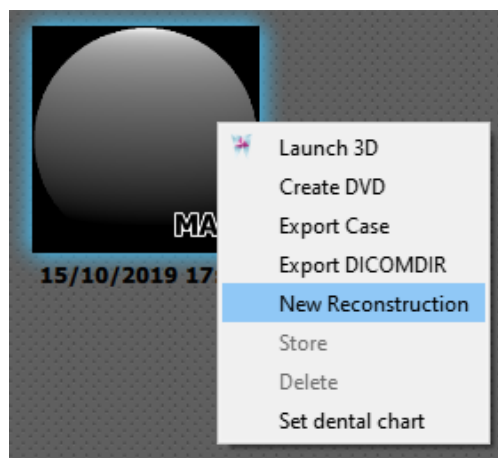

Figure 34

The following window will be displayed:

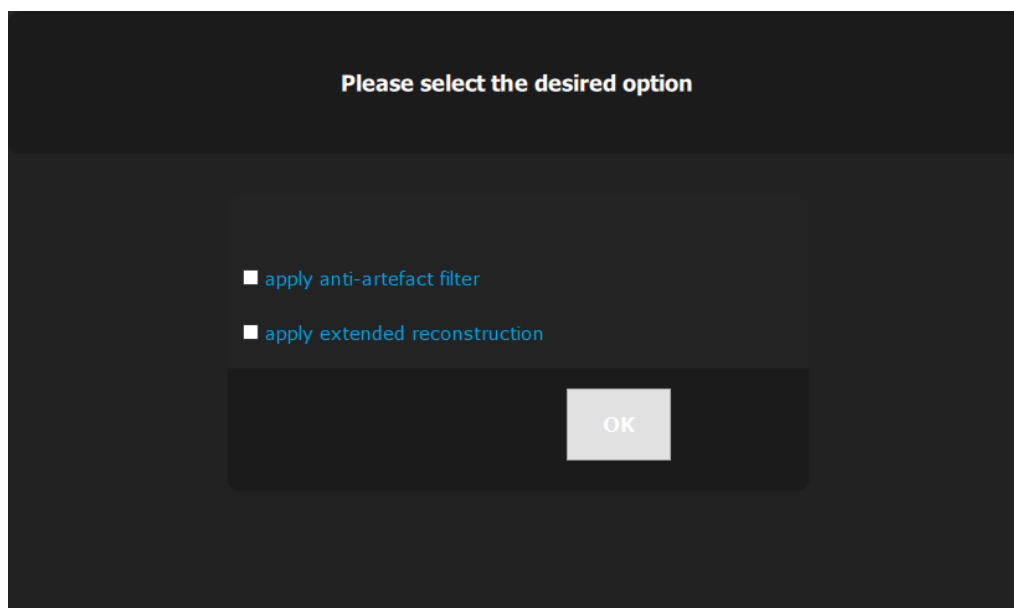

Figure 35



Note

The “apply extended reconstruction” option is enabled only if the Extended Volume package has been activated on the equipment.



Note

To launch the “apply extended reconstruction” option, x-mind optima 3D must be connected to the workstation.

Click on OK button to run a new reconstruction without MAR correction or flag the “apply anti-artefact filter” option and click on OK button to run a new reconstruction with MAR correction.

A 3D study reconstructed with MAR filter (identified with the MAR label), is created in the exam list of the patient folder as shown in figure:

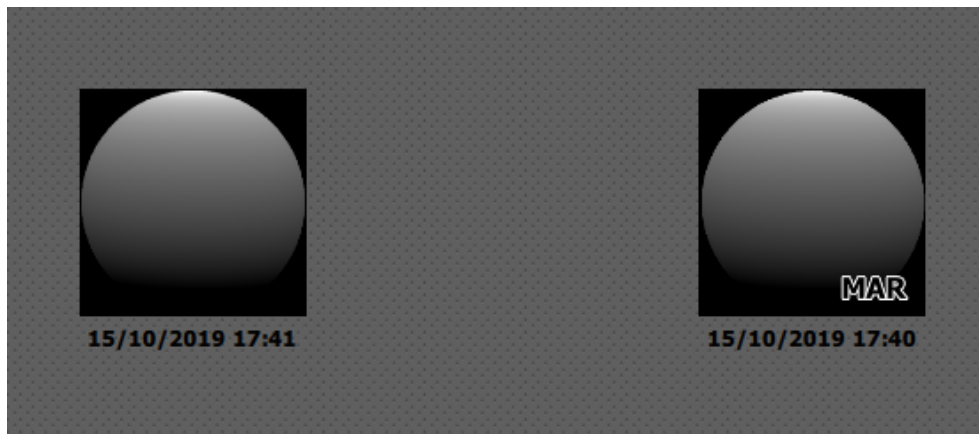

Figure 36



Note

After having run a first reconstruction, if a further reconstruction is launched with one or both options as in Figure 35, the new 3D study will overwrite the previous reconstructed study.

14. CEPH EXAMS

On x-mind optima 3D CEPH version, the horizontal linear scanning of the skull is performed maintaining the focus in a fixed position and guaranteeing the same projection geometry as if using a film. The X-ray source is automatically aligned to digital sensor. The use of a secondary collimator ensures the minimum level of radiation to the patient limiting the size of the fan shaped beam to the target region of interest.

A digital filter is automatically applied to lateral cephalometric images to enhance the visibility of soft tissues profile while preserving the bone structures.

Two different acquisition modes, selectable from the GUI, are available:

- HD - High Definition (no binning) for the enhancement of the finest details
- HS - High Speed (2x2 binning) for patient dose reduction and for limiting the incidence for motion artefacts.

The reduced height is obtained through a dedicated mechanical collimation.

A dedicated removable plate is provided for performing hand-wrist (carpus) analysis, mainly used for the assessment of the patient's bone growth trend.



Note

Especially with pediatric patients evaluate the opportunity to use the HS mode with reduced height in order to reduce the dose delivered to the patient.

14.1 Latero-Lateral projection



In LL mode (asymmetric) the horizontal scanning area can be selected between three lengths 18, 24 or 30 cm in full height (24 cm) or reduced height (18 cm).

14.2 Antero-Posterior projection (symmetric)

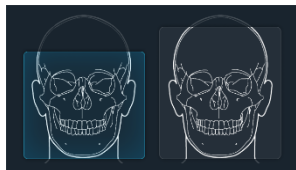

In AP mode (symmetric) the horizontal scanning area is fixed at 24 cm, available in full height (24 cm) or reduced height (18 cm).

14.3 Carpus



The Carpus mode is equivalent in size to the AP mode full height (18x24 cm) but it's available only in HD mode.

15. PATIENT POSITIONING IN PANORAMIC

15.1 General rules



Note

These positioning instructions are valid both for adult and pediatric patients.



Note

In general with child and adolescent patients, before taking the exposure it is suggested to run the exam in test mode in such a way to show the young patient how the unit works and make them feel comfortable.



Note

The chinrest height when the column is in its lower position is at 97.8 cm (38.5") from the floor. As a consequence, the unit can be used with patient at least 118 cm (3 ft 10.4") high.



Warning

Before positioning the patient always apply the disposable protection devices (class I Medical Device Regulation 745/2017/EU and subsequent amendments) to the parts that come into contact with the patient: chin rest, temple rest, bite block and handlebar.

1. Ask the patient to remove all metallic objects located in the area to be X-rayed (necklaces, earrings, glasses, hairpins, removable dental prosthesis, etc.). Ensure there are no thick garments in the area to be X-rayed (coats, jackets, ties, etc.).
2. Ask the patient to wear the protective apron, making sure to avoid interference with the trajectory of the X-ray beams.
3. Place the patient in a standing position at the Panoramic chin rest. With the "Column movement" keys (1 - Figure 22), raise/lower the column until the chin support is aligned with the patient's chin.



Warning

The equipment has a red emergency button located on the upper part of the unit, near the power switch, that only stops the column movement. In case of an emergency column situation, press the emergency button to stop the movement.



Warning

During the patient positioning, make sure the equipment cannot collide with any object in the room.



Note

If the column doesn't move, check that the emergency button is not pressed. Rotate the button to release it. In case the problem persists, power off the machine and wait for about 20-30 seconds, then power on again the machine; if the problem still persists, call the Technical Service.

4. Position the patient with the temple clamps ensuring that the chin rests on the special support; the hands should rest on the front handles. Ask the patient to bite the

reference notch of the bite with his incisors. In the case of edentulous patients, he/she must rest the chin against the reference shoulder of the edentulous chin support.

5. Press the "Luminous centering devices" key (2 - Figure 22). Two laser beams will light up the sagittal medial plane line and the horizontal line. Position the patient's head in such a way as to ensure that the luminous beams fall in correspondence with respective anatomical references (Figure 37).
6. At this point, the patient has to step forward making sure of keeping his head within the pre-aligned anatomical references. This ensures a greater extension of the spine in the cervical area, improving the darkening of the X-ray in the apical area of the incisors, and avoiding the collision of the tube-head with the patient's shoulders.
7. Close the temple clamps to help the patient maintain a correct position.

Note



The laser centering devices remain on for approximately 2 minute; shutdown can be anticipated by pressing the "Luminous centering device" key (2 - Figure 22) or, with alignment complete, by pressing the "Patient entrance" key (6 - Figure 22) to begin preparation for exposure.

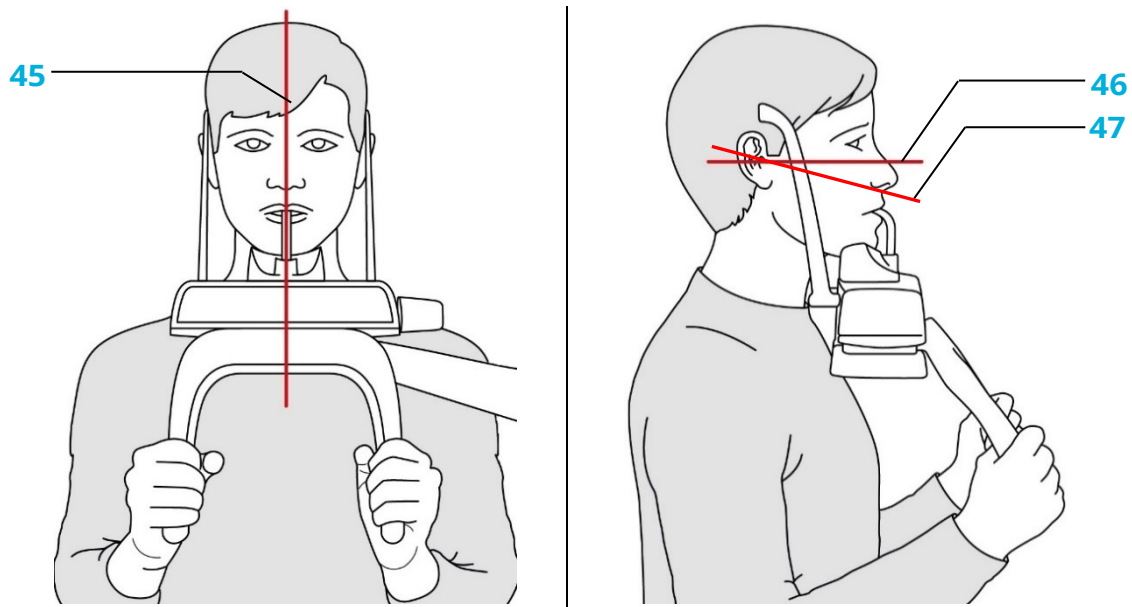

45 - Mid-Sagittal line

46 - Frankfurt plane line: plane that identifies a line that ideally connects the hole in the auricular canal - external auditory meatus - with the bottom edge of the orbital fossa

47 - Ala-tragus line: plane that identifies a line that ideally connects the anterior nasal spine and the center of the external auditory meatus.

Figure 37: Reference lines

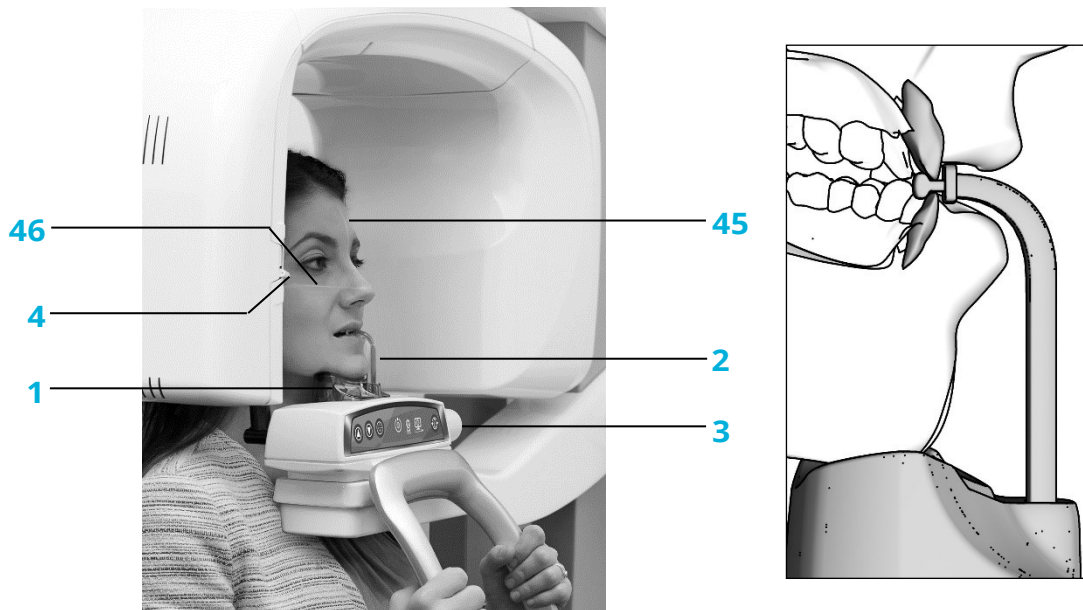

Label	Description	Label	Description
45	Sagittal medial line	2	Centering bite
46	Frankfurt line	3	Temple claps closing/release knob
1	Panoramic chin support	4	Laser Knob

Figure 38: 2D Panoramic / 3D Dentition patient positioning

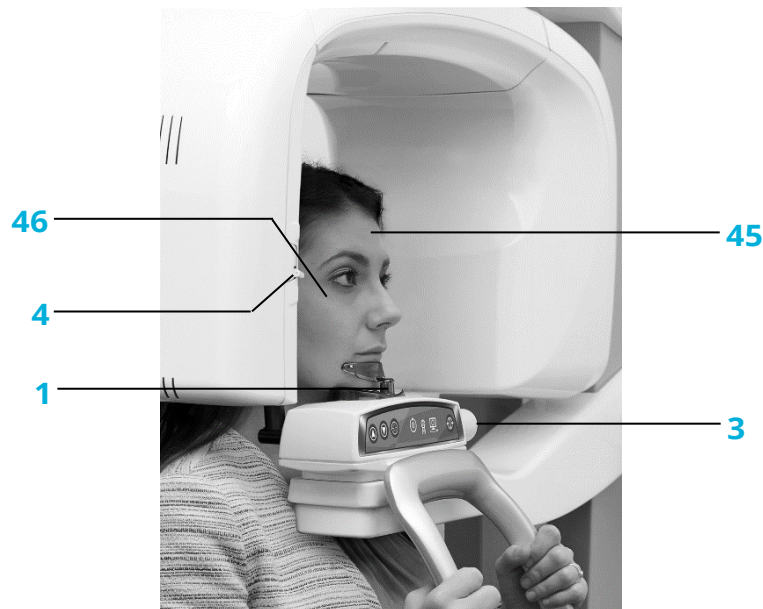

Label	Description	Label	Description
45	Sagittal medial line	3	Temple claps closing/release knob
46	Frankfurt line	4	Laser Knob
1	Tiniest chin support		

Figure 39: 2D Sinus / 3D Sinus / 3D TMJ / 3D Maxillary patient positioning



Label	Description	Label	Description
45	Sagittal medial line	3	Temple claps closing/release knob
46	Frankfurt line	4	Laser Knob
1	TMJ positioner		

Figure 40: 2D TMJ closed mouth patient positioning



Label	Description	Label	Description
45	Sagittal medial line	3	Temple claps closing/release knob
1	TMJ positioner	4	Laser Knob

Figure 41: 2D TMJ open mouth patient positioning

15.2 2D exams

- Mid sagittal plane must be centered and vertical.
- Frankfurt plane (the plane that identifies a line that ideally links the ear hole - the auditory meatus - with the lower part of the orbital fossa) must be horizontal.
- Spine should be well stretched.
- In case of use of the bite, patient's incisors must be positioned into the reference notch.
- Patient's tongue must be against the palate.
- Patient must stay motionless during the examination.



Note

During TMJ C/O exam, at the end of phase 1 let the patient exit, press >O< to make the rotating arm return back and then let again the patient in to run the phase 2 of the exam.

15.3 3D exams

- Mid sagittal plane must be centered and vertical.
- Camper plane (ala-tragus plane) must be horizontal.
- Patient's incisors must be positioned into the reference notch of the bite.
- Patient must stay motionless during the examination.

16. PATIENT POSITIONING IN CEPH



Note

These positioning instructions are valid on x-mind optima 3D CEPH version both for adult and pediatric patients.



Note

In general with child and adolescent patients, before taking the exposure it is suggested to run the exam in test mode in such a way to show the young patient how the unit works and make them feel comfortable.



Warning

Before positioning the patient always apply the disposable protection devices (class I Medical Device Regulation 745/2017/EU and subsequent amendments) to the parts that come into contact with the patient: chin rest, temple rest, bite block and handlebar.

1. Ask the patient to remove all metallic objects located in the area to be X-rayed (necklaces, earrings, glasses, hairpins, removable dental prosthesis, etc.). Ensure there are no thick garments in the area to be X-rayed (coats, jackets, ties, etc.).
2. Ask the patient to wear the protective apron, making sure to avoid interference with the trajectory of the X-ray beams.
3. Open the ear centering device to its maximum span by pressing the ear rods release lever located on the upper part of the outer rod and pulling the rods apart.
4. Move the nose rest away outwardly to its maximum extension. Manually rotate the head positioning device according to the cephalometric projection to be made (AP or LL), by rotating the upper part of the ear centering device (Figure 42).



Figure 42

5. With the keys "Column movement" up/down set the proper position of the column, with centering pins horizontally aligned with the ear.

6. If a Latero-Lateral examination is performed, position the nose rest in such a way to be in contact with the nasion reference point on the patient, which is the most anterior point of the frontonasal suture that joins the nasal part of the frontal bone and the nasal bones.

7. If a Postero-Anterior exam is performed, rotate the nose rest out of the imaging area. The nose rest is held in place by a magnet.
8. Align horizontally the patient's Frankfurt plane with the help to the reference line on the external rod.
9. Adjust the head position in such a way to get the mid-sagittal plane vertical and parallel (in LL mode) or perpendicular (in AP mode) to the detector, then close the head support and block the patient head by gently pushing the ear rods towards the patient

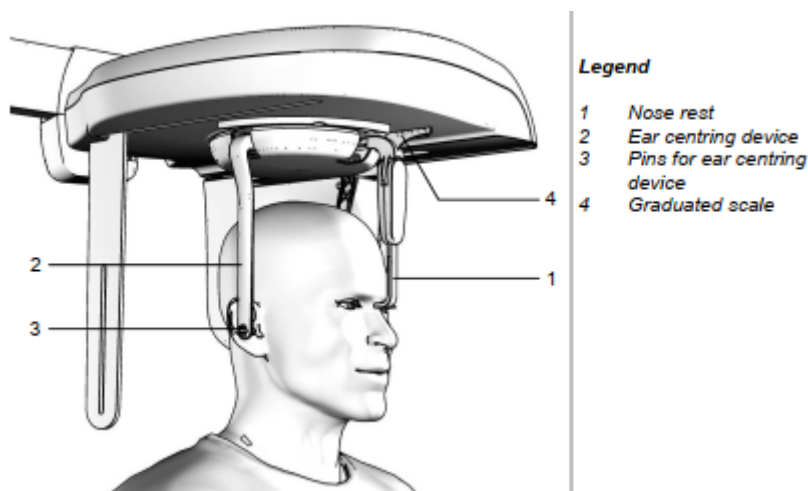

Figure 43

16.1 Bone growth assessment (Carpus)

The cephalometric device can also be used to carry out the Carpus exam, specifically intended for evaluating the state of calcification and the patient's bone growth trend. The image format is fixed to 18x24 Symmetric. It is therefore necessary to position the auricular rods and the nose-rest as for the cephalometric AP examination, in order to avoid interferences with the X-ray beam.



Figure 44

1. Turn the ear centering device to the Antero-Posterior position and open the rods to the maximum extent
2. Rotate the nose-rest to the parking position.
3. Hook up the positioning support for hand projection, by screwing it on the related housings close to the ear centering device. The size of the support labeled as "sensor side" has to be mounted face the sensor (Figure 44).
4. Place the patient slightly to the side of the cephalometry device.
5. Position the patient's hand on the positioning support on the sensor side. The support leads the operator to place the hand in the centre of the irradiated area (centre of the square). The common radiological procedure to assess bone growth in children's, suggests placing the end of the middle finger tangent to the reference line. The patient's hand must be fully in contact with the metal plate and it must form a vertical line with the arm, in order to avoid any risk of collision with the sensor during the scanning movement.

17. ERROR MESSAGES

The error messages are divided into different areas that can be distinguished by the error number; the following table contains the different errors with meanings.

Main MCU board	
Code	Error description
001 / 003	Internal MCU error
500 ÷ 505	MCU Ethernet errors
MCU EEPROM configuration	
Code	Error description
100 / 101	Configuration area parameter doesn't match the expected one
102	Wrong version number in configuration area
103 / 104	Timeout error occurred during an EEPROM erase/write operation
Rotation Motor	
Code	Error description
200	Zero position optical sensor of rotation axis always activated
201	Zero position optical sensor never activated
202 / 203	Zero position optical sensor of rotation still active after exiting from zero sensor
204	Unexpected activation of rotation optical sensor
205	Timeout on rotation
Y translation motor	
Code	Error description
240	Zero position micro Y always active
241	Zero position micro Y never active
243	Timeout on Y axes
Disk collimator	
Code	Error description
260	Collimator timeout on zero positioning
Chin rest	
Code	Error description
265	Zero position micro chin rest always active
266	Zero position micro chin rest never active
268	Chin rest timeout
Hardware keyboard (U.I.C.)	
Code	Error description
270 / 271	Hardware key fault
X-Ray Controls	
Code	Error description
360	RX button pressed on start-up or before exam
362	RX button released during emission
Sensor Ready	
Code	Error description
370	Sensor ready lost during exposure
371	Sensor not ready
374	The computer connection drops or times out during exam

375	Sensor took long in configuration mode (while in preheat)
376	The mobile sensor is not detected in CEPH position; The sensor presence has changed from the initial situation

Can bus

Code	Error description
380	CAN bus invalid reply

Temperature sensor

Code	Error description
500 ÷ 503	Temperature sensor reading error

CCU Board

Code	Error description
600 / 601 / 605	CCU malfunctioning errors
602÷ 604	CEPH operative errors
606	Nasion calibration error
611	Internal CCU error
623 / 624	CCU EEPROM errors
630 ÷ 635	Sensor movement errors
640 ÷ 645	Secondary collimator movement errors
650 ÷ 661	4 blade collimator movement errors
670 / 671	CAN bus errors
680	CEPH exam aborted

Generator Board

Code	Error description
750	Generator board initialization error
751	Alarm "overvoltage kV"
752	Alarm "overload on filament" on Generator board
753	Alarm "overload anodic current"
754	Alarm "filament not OK"
755	Alarm "backup timer"
756	Alarm "PFC not OK"
757	Alarm "Brown OUT"
758	Alarm "NO X-ray"
759	Alarm "unexpected emission"
760	Alarm "NO RX button command"
761	Alarm "NO X-ray emission"
762	Bad unit status: emission flag detected unexpectedly
763	kV analog feedback out of range
764	mA analog feedback out of range
765	Filament analog feedback out of range
766	Generator board reset due to a brown out
767	Generator board reset due to low voltage detection
768	Generator board reset due to a watchdog timeout
769	Generator board reset due to a stack overflow
770	Mismatch between generator board (A2) and MCU board (A1) types (2D / 3D)

Keyboard

Code	Error description
850	One or more keycodes are pressed
852	Button >0< pressed during movements

PC software operator interface (GUI)

Code	Error description
1201	Setup menu: write data EEPROM failure
1202	Unexpected value detected by the software
1203	Software allocation failure
1204	Exposure parameters failure
1205	Image buffer allocation failure

PC driver interface (ASP)

Code	Error description
1401	Sensor connection lost during exam
1402	Sensor communication failure
1403	Software watchdog error
1404	Sensor does not detect X-rays during exam
1405	Sensor frame lost during exam
1406	Error in sensor frame rate

18. MAINTENANCE



Note

Maintenance and inspection procedure must be performed without patient positioned in the equipment.

This unit, like all other electrical appliances, must be used correctly and also serviced and controlled at regular intervals. This precaution ensures safe and efficient performance.

Regular maintenance consists of checks performed by the operator and/or by a qualified technician.

The operator can control the following items:

Frequency	Type of check	Method
Daily	Functioning of the indicator lights	Visual inspection
Daily	Check that the cables do not show signs of breaking or wear	Visual inspection
Daily	Check that the panoramic /3D patient support and the panoramic and the CEPH temple rods are stable	Practical inspection
Daily	Check that the unit is not damaged externally in such a way that the safety of protection from radiation is compromised	Visual inspection
Daily	Check that there are no traces of oil on the tube-head	Visual inspection
Daily	Check that rotating arm and CEPH arm movements are smooth	Practical inspection
Monthly	Integrity of equipment and labels	Visual inspection
Every 6 Months	QC test	See paragraphs 8.4 and 8.5



Warning

If the operator detects irregularities or failures, he must immediately call Technical Service.

Besides the above controls, the Service Engineer will also check the following during preventive maintenance:

Frequency	Type of check
Annually	Correct equipment centering
Annually	Check technical factors
Annually	Perform sensor calibration
Annually	Check that the fixing screws are tightened

19. IMAGE ASSESSMENT

19.1 Panoramic image assessment

Panoramic radiography is an exam of the maxillo-facial region normally used to view the dental region inside the complete head and sinuses-orbital complex.

With a good panoramic exam, you can distinguish the main anatomic structures that are simplified in the diagram below (which indicates only the main ones and is not complete).

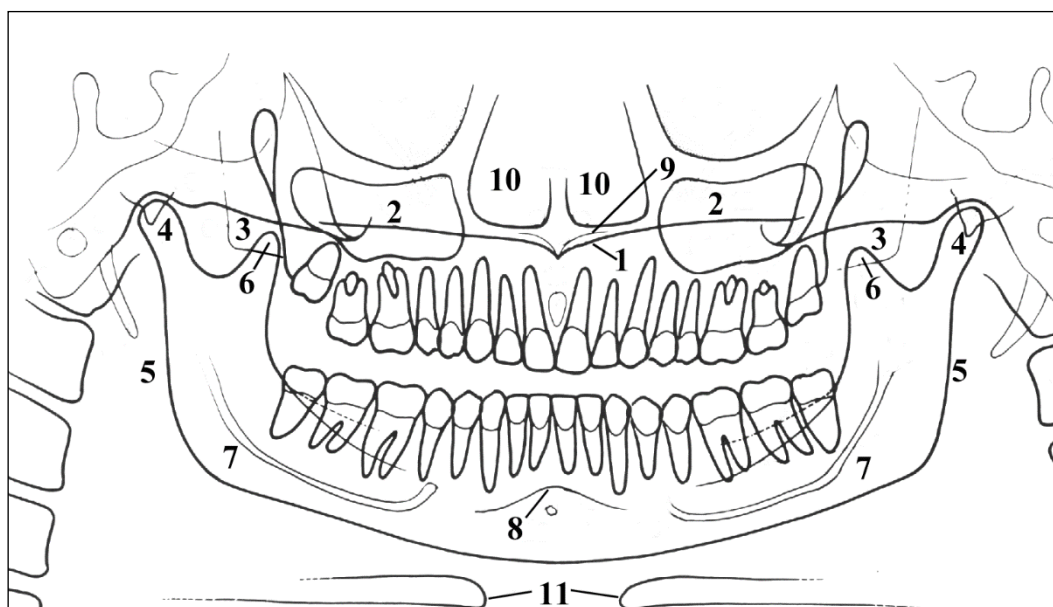

Figure 45

Ref.	Anatomic structure
1	Palatal plane
2	Maxillary sinus
3	Maxilla and maxillary tuberosity
4	Temporo mandibular condyle
5	Ascending ramus of the TMJ
6	Coronoid process (overlap with maxilla)
7	Mandibular canal
8	Chin foramen
9	Anterior nasal spine
10	Nasal cavities
11	Ioid bone (normally duplicated)

19.2 Proper positioning of the patient

Patient positioning is determining to get good quality radiography. This is due to the fact that the shape of the focused area, e.g. of the layer clearly shown on the image, tends to follow the dental arch and has a non-constant deepness. The objects outside this focused area will therefore appear blurred on the radiography.

1. The patient should not wear clothes that may interfere with the X-ray beams, also to leave more space between the patient's shoulders and the rotating arm of the equipment. Care must be taken in order to avoid interference between the X-ray beam and the protective apron worn by the patient.
2. Metal objects (necklaces, earrings etc.) must be avoided; these objects not only create radio-opaque images in their own position, but also false images projected in other parts of the radiography, so disturbing the correct view of the anatomy.
3. Patient's incisors must be positioned into the reference notch of the bite.
4. Frankfurt plane (plane passing through the inferior margin of the orbit and the upper margin of the ear canal) must be horizontal.
5. Mid-Sagittal plane must be centered and vertical.

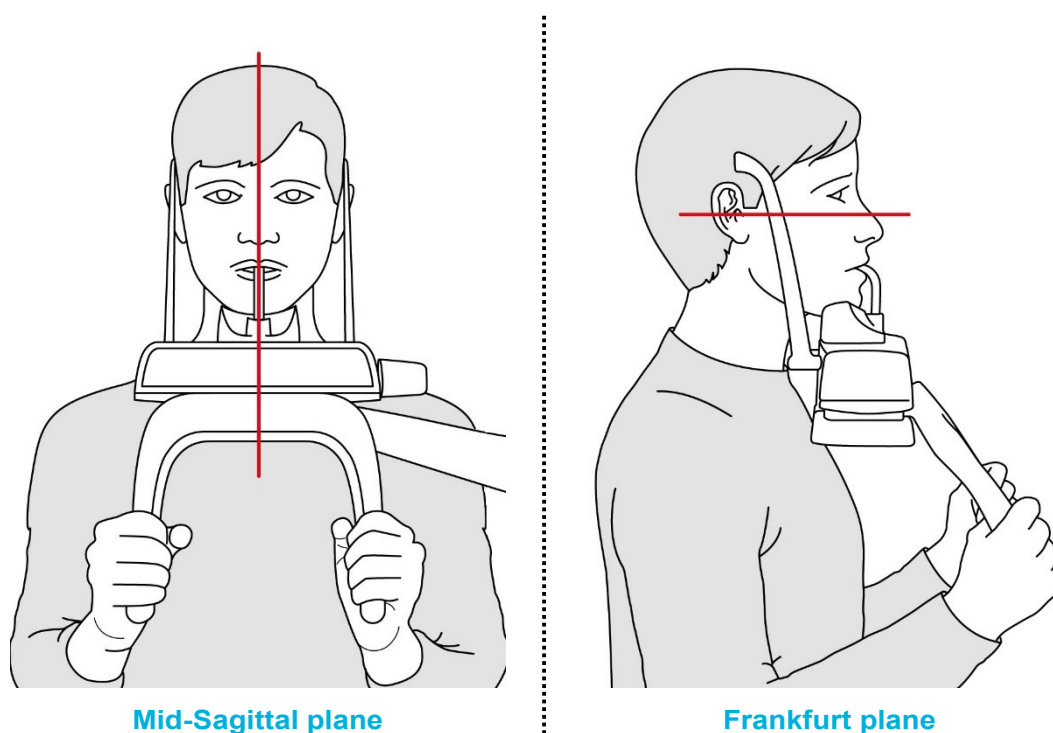

Figure 46

6. Spine should be well stretched, this is normally obtained by asking the patient to step forward, making sure that all other conditions are unchanged. If not properly extended, the spine will cause the appearing of a lower exposed area (clearer) in the front part of the image.
7. Instruct the patient to swallow and keep the tongue against the palate. Patient's tongue must be held closely to the roof of the mouth during the exposure, otherwise a dark air space between the dorsum of the tongue and the palate could obscure the apical region of the maxillary teeth.
8. Patient must stay motionless during the examination.

The result of all the above listed actions will be a radiography where all the parts are properly exposed and are well identifiable as shown in Figure 47.



Figure 47

In a good panoramic image, all anatomic structures are well represented and an equal magnification and sharpness of all structures can be seen.

The image must be symmetric, with the ascending rami of the temporo mandibular joints almost parallel and showing posterior vertical borders. The occlusal plane is quite smiling, despite this the palatal plane does not overlap the apex of the upper arch and therefore allows a good view of the apex itself. The spine is well compensated.



Note

The region of the incisors is the most critical because the anterior portion of the image layer is very narrow. Points 3 and 4 are determining for a good result.



Note

Any flaring of dentition may not allow crowns and apices of both arches to fit in the image layer at the same time. For these patients, you must purposely move him/her further forward in order to move the apices into the image layer.

19.3 Patient positioning errors in panoramic

19.3.1 Turned head

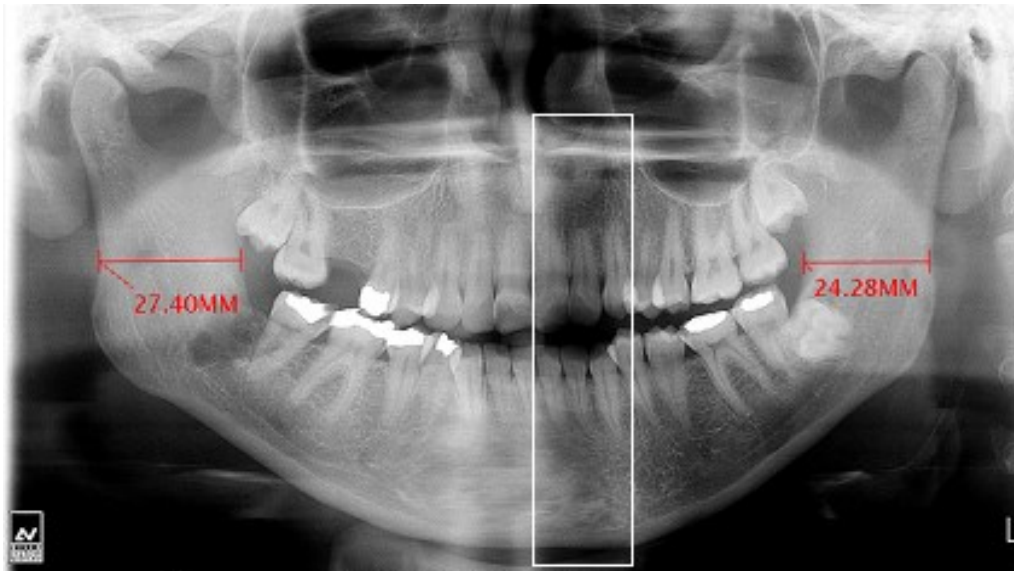
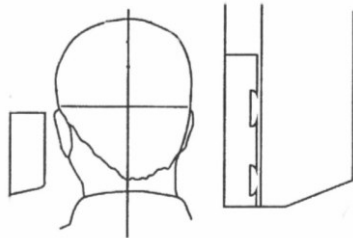

Figure 48



Problem

The patient's head is turned to one side (left or right) in the mid-sagittal plane.

Effects

Condyles are different in size.
The ramous on one side is much wider that the other one.
Asymmetric spine compensation.

19.3.2 Tilted head

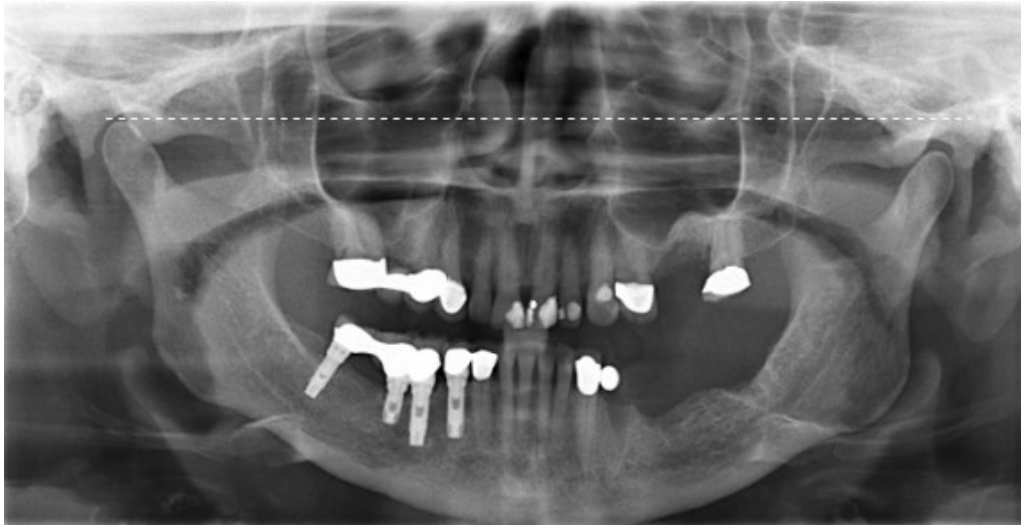
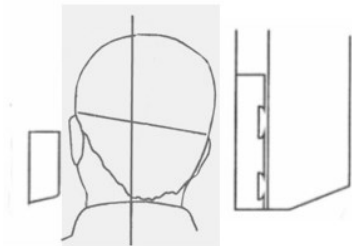

Figure 49



Problem

The patient's head is tilted to one side.

Effects

One condyle appears higher than the other one and the inferior border of the mandible is slanting.

19.3.3 Downward angulation of the head



Figure 50



Problem

The Frankfort plane is tilted downward.

Effects

The roots of the mandibular anterior teeth are positioned outside the focal trough so it is out-of-focus and blurred (Figure 50 A).

The shadow of the hyoid bone is typically superimposed on the anterior mandible.

Condyles may be cut off at the top of the radiograph.

Pre-molars are severely overlapped.

Severe curvature of the occlusal plane.

19.3.4 Backward angulation of the head



Figure 51



Problem

The Frankfurt plane is tilted backward.

Effects

The roots of the maxillary anterior teeth are positioned outside the focal trough so it is out-of-focus and blurred (Figure 51 A).

The hard palate is superimposed over the apices of the maxillary teeth.

Both condyles may be off the edges of the image area.

The upper incisors can be blurred.

Flattening of the occlusal plane.

19.3.5 Tongue effect

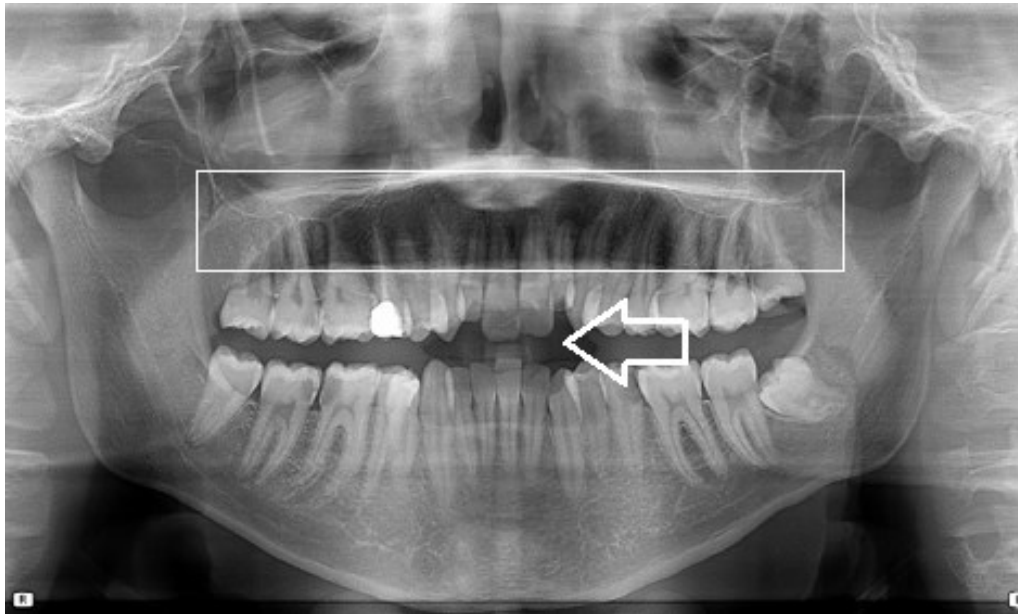
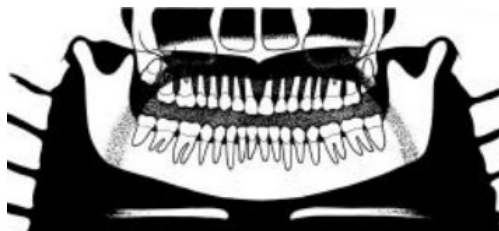

Figure 52



Problem

The patient's tongue was not held closely to the roof of the mouth during the exposure.

Effects

A dark air space between the dorsum of the tongue and the hard and soft palates (palatoglossal air spaces) obscures the apical region of the maxillary teeth.

19.3.6 Spine effect

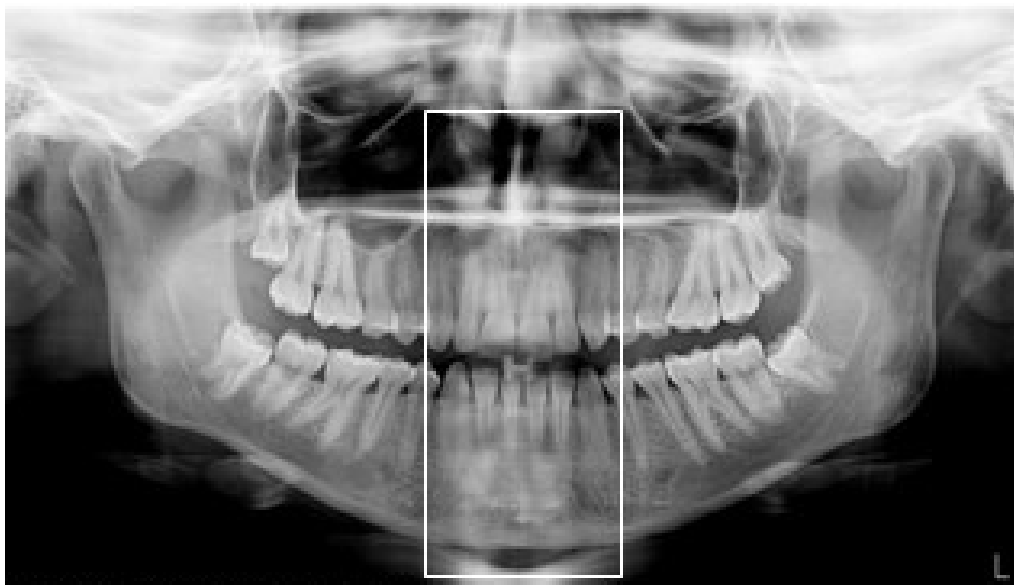
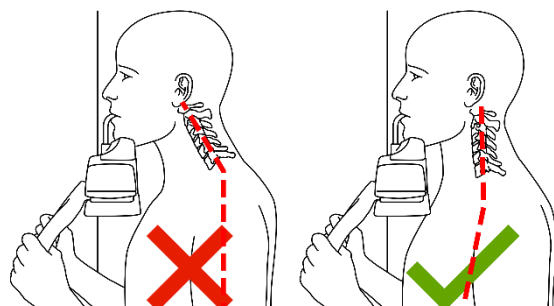

Figure 53



Problem

The patient is slumped.

Effects

The spinal column isn't well stretched causing a ghost image of the spine superimposed in the center of the image.

19.4 CEPH image assessment (CEPH version only)

The images obtained using cephalometric radiography are commonly used to perform a cephalometric analysis, which allows angle and linear measurements to be made, including:

- the outline inclination of the anterior teeth;
- the positional relationship of the mandibular and maxillary dental bases to each other and to the cranial base;
- the relationship between the bones of the skull and the soft tissue profile of the face.

On a good cephalometric image, the below anatomical points (underlined the most important) should be visible: Nasion (N), Menton (Me), Sella (S), Subspinale (A), Supramentale (B), Orbitale (Or), Basion (Ba), Porion (Po), Pterigodeo (Pt), Anterior nasal spine (Ans), Posterior Nasal spine (Pns). Furthermore, the soft tissue profile (nose, lips, chin) should be well represented.

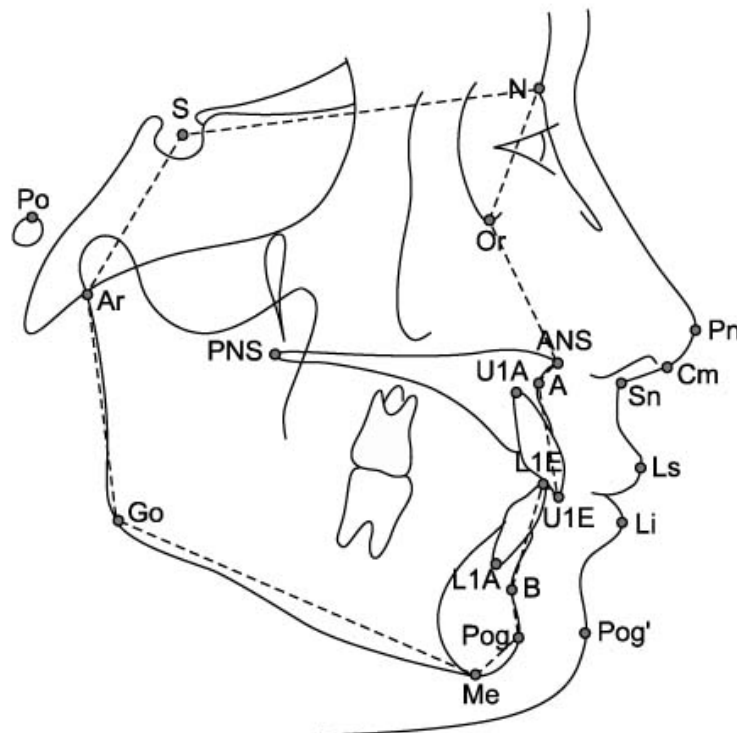

Figure 54

19.5 Patient positioning errors in CEPH (CEPH version only)

19.5.1 Tilted Frankfurt plane



Figure 55



Problem

The Frankfurt plane is tilted (backward/forward).



Effects

A wrong alignment of the Frankfurt plane can impact the effectiveness of the analysis.

19.5.2 Tilted mid-sagittal plane

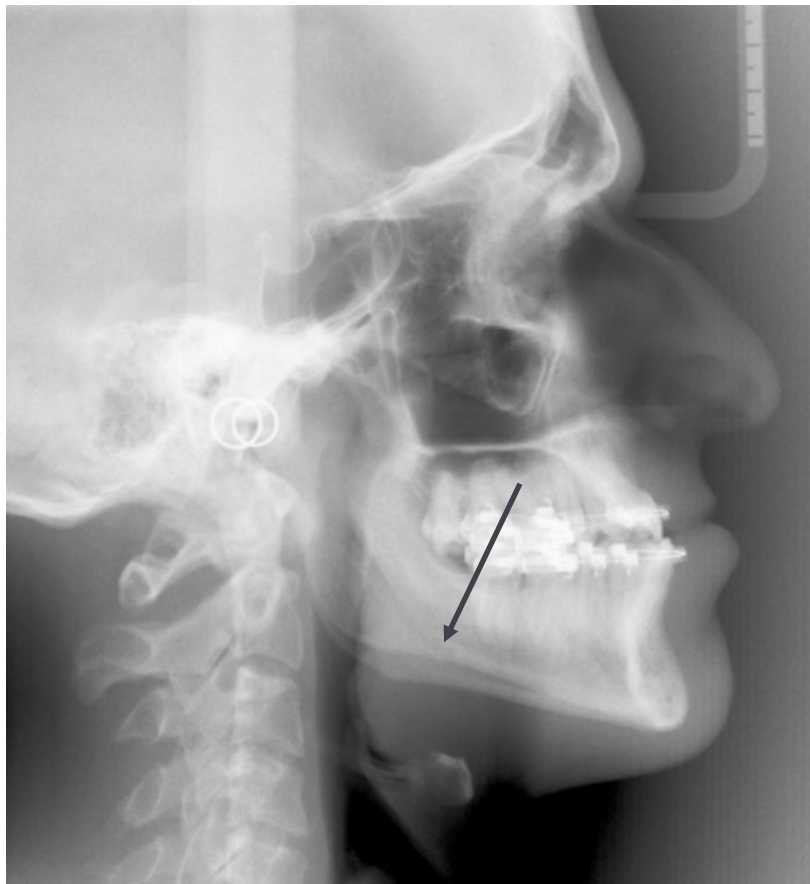
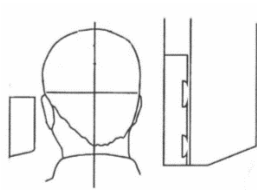

Figure 56



Problem

The Mid-sagittal plane is tilted.

Effects

The misalignment of the mandibular profiles (doubling) can impact the effectiveness of the analysis.

MAINTENANCE LOGBOOK

Installation: Date Technician

Maintenance: Date Technician

Cause

Maintenance: Date Technician

Cause

Maintenance: Date Technician

Cause

Maintenance: Date Technician

Cause

Maintenance: Date Technician

Cause

Maintenance: Date Technician

Cause

Maintenance: Date Technician

Cause

THIS PAGE IS INTENTIONALLY LEFT BLANK

EU DECLARATION OF CONFORMITY

ACCORDING TO THE REGULATION (EU) 2017/745

de Götzen srl - Strada Provinciale Busto-Cassano, 3 - 21054 Fagnano Olona (VA) - Italy

SRN CODE: IT-MF-000013302

BASED ON CERTIFICATE NO.	108/MDR
ISSUED BY	IMQ S.P.A. No. 0051

Evaluation of conformity based on the quality management system according to Annex IX chapter I, III of Regulation (EU) n. 2017/745

Declares on his sole responsibility that the medical device:

Panoramic, cephalometric and tomographic X-ray equipment

MODEL:	X-MIND optima 3D
REF. CODE:	xxxxx
TRADE MARK:	Acteon
TRADE NAME:	x-mind optima 3D
BASIC UDI-DI:	++D804W12QK
INTENDED USE:	<p>X-MIND prime 3D is a digital panoramic, cephalometric and tomographic extra-oral X-ray equipment, indicated for use in:</p> <ul style="list-style-type: none"> - producing panoramic X-ray images for diagnostic examination of dentition (teeth), jaws and oral structures; - producing radiographs of maxillofacial region and parts of the skull for cephalometric examination, if equipped with CEPH arm; - producing radiographs of hands and wrists for carpus examination, if equipped with CEPH arm; - producing tomographic images of the oral and maxillofacial region, for diagnostic examination of dentition (teeth), jaws, oral structures and some cranial bones, if equipped with CBCT option.

	X-MIND optima 3D is not intended to be used in emergency radiology.
RISK CLASS:	I Ib
S/N:	xxxx
MANUFACTURING DATE:	mm-yyyy

complies with the following: Regulation (EU) 2017/745, Directive 2006/42/CEE and Directive 2011/65/EU-RoHS.

complies with the general safety and performance requirements defined by Annex I of the Regulation (EU) 2017/745 and it is classified as **Active** medical device, class I Ib according to Annex VIII Classification rules, Rule 10.

Furthermore,

It is here declared that subscribing company will keep all the technical documentation mentioned in Annex II of the Regulation (EU) 2017/745 available for Sanitary Authority for a period of 10 years from the last production of the device to which this declaration is addressed to.

Has been adopted the procedure relative to the Declaration of Conformity according to Annex IV of the Regulation (EU) 2017/745.

Fagnano Olona, 02/12/2024



Alvis Reither
Legal Representative
by Proxy

CE 0051

de Götzen S.r.l.

Strada Provinciale Busto-Cassano n.3 • 21054 FAGNANO OLONA (VARESE)

• ITALY

Tel +39 0331 376 762 • Fax +39 0331 376 763

E-mail: imaging.italysupport@acteongroup.com • www.acteongroup.com

 **acteon**