

# VistaScan Mini Easy 2.0

XPS07.1D...



EN Installation and operating instructions



2144100118L02 2410V006

The current version of the installation and operating instructions is available in the Download Center:



<https://qr.duerdental.com/2144100118>

# Contents



## Important information

<b>1 About this document</b> . . . . .	3
1.1 Warnings and symbols . . . . .	3
1.2 Copyright information . . . . .	4
<b>2 Safety</b> . . . . .	4
2.1 Intended purpose . . . . .	4
2.2 Intended use . . . . .	4
2.3 Improper use . . . . .	4
2.4 General safety information . . . . .	5
2.5 Specialist personnel . . . . .	5
2.6 Electrical safety . . . . .	5
2.7 Essential performance characteristics . . . . .	6
2.8 Notification requirement of serious incidents . . . . .	6
2.9 Only use original parts . . . . .	6
2.10 Transport . . . . .	6
2.11 Disposal . . . . .	6
2.12 Protection from threats from the Internet . . . . .	7



## Product description

<b>3 Overview</b> . . . . .	8
3.1 Scope of delivery . . . . .	9
3.2 Accessories . . . . .	9
3.3 Optional items . . . . .	9
3.4 Consumables . . . . .	9
3.5 Wear parts and replacement parts . . . . .	10
<b>4 Technical data</b> . . . . .	11
4.1 Image plate scanner (XPS07.1D...) . . . . .	11
4.2 Image plate . . . . .	15
4.3 Light protection cover . . . . .	15
4.4 Type plate . . . . .	16
4.5 Evaluation of conformity . . . . .	16
4.6 Simplified declaration of conformity . . . . .	16
<b>5 Function</b> . . . . .	16

5.1 Image plate scanner . . . . .	16
5.2 Image plate . . . . .	17
5.3 Light protection cover . . . . .	18
5.4 Protective cover . . . . .	18
5.5 Image plate storage box . . . . .	18
5.6 Bite protector (optional) . . . . .	18



## Assembly

<b>6 Requirements</b> . . . . .	19
6.1 Installation/setup room . . . . .	19
6.2 System requirements . . . . .	19
6.3 Monitor . . . . .	19
<b>7 Installation</b> . . . . .	19
7.1 Setting up the unit . . . . .	19
7.2 Electrical connections . . . . .	20
7.3 Connecting the device to the network . . . . .	21
<b>8 Commissioning</b> . . . . .	23
8.1 Configuring the network . . . . .	23
8.2 Configuring the unit . . . . .	23
8.3 Security settings . . . . .	23
8.4 Testing the device . . . . .	24
8.5 X-ray unit settings . . . . .	25
8.6 Acceptance tests . . . . .	25



## Usage

<b>9 Correct use of image plates</b> . . . . .	27
<b>10 Operation</b> . . . . .	28
10.1 Switch on the unit . . . . .	28
10.2 Changing the plate guide . . . . .	29
10.3 X-ray . . . . .	30
10.4 Scanning the image data via a computer . . . . .	32
10.5 Erasing the image plate . . . . .	33
10.6 Switch off the unit . . . . .	33
<b>11 Cleaning and disinfection</b> . . . . .	34
11.1 Image plate scanner . . . . .	34
11.2 Light protection cover . . . . .	35
11.3 Image plate . . . . .	35

- 11.4 Protective cover . . . . . 35
- 11.5 Image plate storage box . . . . . 36
- 12 Maintenance . . . . . 37**
  - 12.1 Recommended maintenance schedule . . . . . 37



## Troubleshooting

- 13 Tips for operators and service technicians . . . . . 38**
  - 13.1 Poor X-ray image . . . . . 38
  - 13.2 Software error . . . . . 42
  - 13.3 Fault on the unit . . . . . 43
  - 13.4 Error message on display . . . . . 45



## Appendix

- 14 Scanning times . . . . . 48**
- 15 File sizes (uncompressed) . . . . . 49**
- 16 Handover record . . . . . 50**
- 17 Country representatives . . . . . 51**

# Important information

## 1 About this document

These installation and operating instructions represent part of the unit.



The manufacturer and the distributor will not offer any guarantee or accept any liability for the safe operation and the safe functioning of the unit if the instructions and information in these installation and operating instructions are not complied with.

The German version of the installation and operating instructions is the original manual. All other languages are translations of the original manual. These operating instructions apply to:

**VistaScan Mini Easy 2.0 (XPS07.1D1)**

REF: 2144100500

**VistaScan Mini Easy 2.0 (XPS07.1D2)**

REF: 2144100505

### 1.1 Warnings and symbols

#### Warnings

The warnings in this document are intended to draw your attention to possible injury to persons or damage to machinery.

The following warning symbols are used:



General warning symbol

The warnings are structured as follows:



#### SIGNAL WORD

##### Description of the type and source of danger

Here you will find the possible consequences of ignoring the warning

- Follow these measures to avoid the danger.

The signal word differentiates between four levels of danger:

- **DANGER**  
Immediate danger of severe injury or death
- **WARNING**  
Possible danger of severe injury or death
- **CAUTION**  
Risk of minor injuries
- **NOTICE**  
Risk of extensive material/property damage

#### Other symbols

These symbols are used in the document and on or in the unit:



Note, e.g. specific instructions regarding efficient and cost-effective use of the unit.



Order number



Serial number



Medical device



Lot designation



Model number



CE labelling



Conformity mark for the United Kingdom of Great Britain and Northern Ireland



Manufacturer



Date of manufacture



Authorised representative for Switzerland



Dispose of correctly in accordance with EU Directive 2012/19/EU (WEEE).



Refer to the accompanying electronic documents.



Observe the operating instructions.



Refer to Operating Instructions.



Wear protective gloves.



Disconnect all power from the unit.



Do not reuse



Health Industry Bar Code (HIBC)

 DC current



Warning – dangerous high voltage



Warning - laser beam



This way up / store and transport in an upright position



Keep dry



Stacking limits



Lower and upper humidity limits



Lower and upper temperature limits



Lower and upper atmospheric pressure limits



Fragile, handle with care



Keep away from sunlight

## 1.2 Copyright information

All circuits, processes, names, software programs and units mentioned in this document are protected by copyright.

The Installation and Operating Instructions must not be copied or reprinted, neither in full nor in part, without written authorisation from the copyright owner.

## 2 Safety

The unit has been developed and designed in such a way that dangers are effectively ruled out if used in accordance with the Intended Use. Despite this, the following residual risks can remain:

- Personal injury due to incorrect use/misuse
- Personal injury due to mechanical effects
- Personal injury due to electrical shock
- Personal injury due to radiation
- Personal injury due to fire
- Personal injury due to thermal effects on skin
- Personal injury due to lack of hygiene, e.g. infection

### 2.1 Intended purpose

#### VistaScan Mini Easy 2.0

The unit is intended exclusively for use in dental applications for the scanning and processing of image data on an image plate.

#### Light protection cover

The functions of the Light Protection Cover are:

- to protect the image plate from light and therefore against accidental erasure
- to protect against cross-contamination

### 2.2 Intended use

#### VistaScan Mini Easy 2.0

The unit may only be operated using accessories and optional articles manufactured by or branded with Dürr Dental.

The unit may only be cleaned using the disinfectants and cleaning agents approved by and specified by the manufacturer.

#### Light protection cover

The Light Protection Cover is a disposable item. The Light Protection Cover is designed exclusively for use with image plate scanners manufactured by or branded with Dürr Dental and image plates manufactured by or branded with Dürr Dental.

### 2.3 Improper use

#### VistaScan Mini Easy 2.0

Any other usage or usage beyond this scope is deemed to be improper. The manufacturer accepts no liability for damages resulting from improper usage. The user bears the sole risk.

This unit is not suitable for monitoring patients over longer periods of time. This unit must not be operated in operating theatres or similar rooms, in which dangers may arise from the combustion of flammable materials.

### Light protection covers

Any other usage or usage beyond this scope is deemed to be improper. The manufacturer accepts no liability for damages resulting from improper usage. In these cases the user/operator will bear the sole risk.

Especially:

- The multiple use of this accessory and reprocessing contrary to the instructions of the manufacturer.

The use of the accessory in combination with other than image plate scanners manufactured by or branded with Dürr Dental and image plates manufactured by or branded with Dürr Dental.

## 2.4 General safety information

- Always comply with the specifications of all guidelines, laws, and other rules and regulations applicable at the site of operation for the operation of this unit.
- Check the function and condition of the unit prior to every use.
- Do not convert or modify the unit.
- Comply with the specifications of the Installation and Operating Instructions.
- The Installation and Operating Instructions must be accessible to all operators of the unit at all times.

## 2.5 Specialist personnel

### Operation

Unit operating personnel must ensure safe and correct handling based on their training and knowledge.

- Instruct or have every operator instructed in handling the unit.

### Installation and repairs

- Have the manufacturer or a qualified company authorised by the manufacturer perform mounting, new installations, modifications, expansions and repairs.

## 2.6 Electrical safety

- Comply with all the relevant electrical safety regulations when working on the unit.
- Never touch the patient and unshielded plug connections or metallic parts of the device at the same time.
- Replace any damaged cables or plugs immediately.

### Observe the EMC rules concerning medical devices

- The unit is intended for use in professional healthcare facilities (in accordance with IEC 60601-1-2). If the appliance is operated in another environment, potential effects on electromagnetic compatibility must be taken into account.
- Do not operate the unit in the vicinity of HF surgical instruments or MRT equipment.
- Maintain a minimum distance of at least 30 cm between the unit and other electronic devices.
- Note that cable lengths and cable extensions have effects on electromagnetic compatibility.

No maintenance measures are required to maintain the EMC basic safety.



### NOTICE

#### Negative effects on the EMC due to non-authorised accessories

- › Use only those accessories named or approved by the manufacturer.
- › Using any other accessories may result in increased electromagnetic interference emissions or the unit having reduced electromagnetic immunity, leading to an erroneous operation mode.



### NOTICE

#### Erroneous operation mode due to use immediately adjacent to other devices or with other stacked devices

- › Do not stack the unit together with other devices.
- › If this is unavoidable, the unit and other devices should be monitored in order to ensure that they are working correctly.



## NOTICE

### Reduced performance characteristics due to insufficient distance between unit and portable HF communication devices

- Keep a distance of at least 30 cm between the unit (including parts and cables of the unit) and portable HF communication devices (wireless units) (including their accessories such as antenna cables and external antennas).

## 2.7 Essential performance characteristics

The VistaScan Mini Easy 2.0 unit does not have any essential performance characteristics as set out in IEC 60601--1 (EN 60601--1) section 4.3. The unit complies with the requirements according to IEC 60601-1.

The device satisfies the requirements set out in IEC 60601-1-2:2014 + A1:2020.

## 2.8 Notification requirement of serious incidents

The operator/patient is required to report any serious incident that occurs in connection with the device to the manufacturer and to the competent authority of the Member State in which the operator and/or patient is established/resident.

## 2.9 Only use original parts

- Only use accessories and optional articles named or authorised by the manufacturer.
- Only use only original wear parts and replacement parts.



The manufacturer and distributor accept no liability for damages or injury resulting from the use of non-approved accessories, optional accessories, or from the use of non-original wear parts or replacement parts.

The use of non-approved accessories, optional accessories or non-genuine wear parts / replacement parts (e.g. mains cables) can have a negative effect in terms of electrical safety and EMC.

## 2.10 Transport

The original packaging provides optimum protection for the unit during transportation.

If required, the original packaging for the unit can be ordered.



The manufacturer and the distributor do not accept liability, even during the warranty period, for damage during transportation due to improper packaging.

- Only transport the unit in its original packaging.
- Keep the packing materials out of the reach of children.
- Do not expose the unit to any strong vibrations or shocks.

## 2.11 Disposal



An overview of the waste keys for Dürr Dental products can be found in the download area:



<http://qr.duerrdental.com/P007100155>

### Unit



The unit must be disposed of properly. Within the European Union, the unit must be disposed of in accordance with EU Directive 2012/19/EU (WEEE).

If you have any questions about the correct disposal of parts, please contact your dental trade supplier.

### Image plate

The image plate contains barium compounds.

- Dispose of the image plate properly in accordance with the locally applicable regulations.
- In Europe, dispose of the image plate in accordance with waste code 20 03 01 "Mixed municipal waste".

## 2.12 Protection from threats from the Internet

The unit is to be connected to a computer that can be connected to the Internet. Therefore, the system needs to be protected from threats from the Internet.

- Use antivirus software and update it regularly. Look for evidence of possible virus infection and, if applicable, check with the antivirus software and remove the virus.
- Perform regular data backups.
- Restrict access to units to trustworthy users, e.g. via a user name and password.
- Make sure that only trustworthy content is downloaded. Only install software and firmware updates that have been authenticated by the manufacturer.

## Product description

### 3 Overview

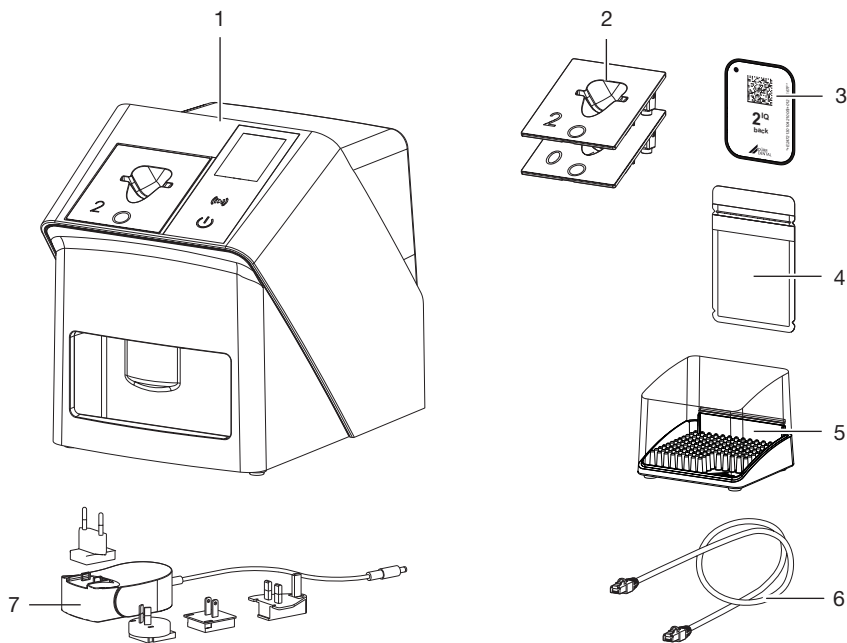

- 1 VistaScan Mini Easy 2.0 image plate scanner
- 2 Plate guides (S0 and S2)
- 3 VistaScan IQ image plate
- 4 VistaScan Light protection cover Plus
- 5 Image plate storage box
- 6 Network cable (3 m)
- 7 Power supply unit with country-specific adapter

### 3.1 Scope of delivery

The following items are included in the scope of delivery (possible variant-specific deviations due to country-specific requirements and/or import regulations):

**VistaScan Mini Easy 2.0**  
**image plate scanner . . . . . 2144110001**

**VistaScan Mini Easy 2.0**  
**image plate scanner . . . . . 2144110005**

**VistaScan Mini Easy 2.0**  
**image plate scanner . . . . . 2144110007**

- VistaScan Mini Easy 2.0 basic unit
- Power supply unit
- Network cable (3 m)
- Cover over device terminals
- Voucher for VistaSoft imaging software
- Plate guides:
  - S0
  - S2 (mounted on unit)
- IQ image plates:
  - S0
  - S2
- Light protection covers Plus:
  - S0
  - S2
- Image plate storage box
- Image Plate Cleaning Wipe
- Protective cover
- Quick start instructions

### 3.2 Accessories

The following items are required for operation of the device, depending on the application:

#### Image plates

- VistaScan image plate IQ S0
- VistaScan image plate IQ S1
- VistaScan image plate IQ S2
- VistaScan image plate IQ S3
- VistaScan image plate IQ S4

#### Light protection covers

- VistaScan Light Protection Cover Plus S0
- VistaScan Light Protection Cover Plus S1
- VistaScan Light Protection Cover Plus S2
- VistaScan Light Protection Cover Plus S3
- VistaScan Light Protection Cover Plus S4
- VistaScan Light Protection Cover Plus White S0
- VistaScan Light Protection Cover Plus White S2

### 3.3 Optional items

The following optional items can be used with the unit:

VistaScan Smart Reader . . . . . 2162100005  
 Wall bracket . . . . . 2144100021  
 Image Plate Storage Case . . . . . 2141-002-00  
 Plate guide tray . . . . . 2144100079  
 VistaPosition PSP  
 Anterior/Posterior Kit Titanium . . . 2130100500  
 VistaPosition PSP  
 Bitewing Kit Titanium . . . . . 2130100600  
 VistaPosition PSP  
 Endo Kit Titanium . . . . . 2130100700  
 VistaPosition PSP  
 Universal Kit . . . . . 2130101800  
 VistaScan bite protector S4 (100x) . 2130-074-03  
 Mobile Connect (for using apps for mobile appliances, e.g. Dürr Dental Imaging iPad app) . . . . . 2100-725-12FC

#### Commissioning and intraoral constancy tests

Intra / extra digital test body . . . . . 2121-060-54

### 3.4 Consumables

The following materials are consumed during operation of the device and must be reordered separately:

#### Cleaning and disinfection

##### Light protection covers

VistaScan light protection cover Plus S0 (100x) . . . . . 2130-080-00  
 VistaScan light protection cover Plus S1 (100x) . . . . . 2130-081-00  
 VistaScan light protection cover Plus S2 (100x) . . . . . 2130108251

VistaScan light protection cover  
Plus S2  
(300x) . . . . . 2130-082-00

VistaScan light protection cover  
Plus S2  
(1000x) . . . . . 2130-082-55

VistaScan light protection cover  
Plus S3  
(100x) . . . . . 2130-083-00

VistaScan light protection cover  
Plus S4  
(100x) . . . . . 2130-084-00

VistaScan light protection cover  
Plus white S0 (100x) . . . . . 2130-080-50

VistaScan light protection cover  
Plus white S2 (300x) . . . . . 2130-082-50

VistaScan IQ image plate S4  
(1x) . . . . . 2130104450

**Plate guides**

Plate guide S0 (1 each) . . . . . 2144100187

Plate guide S1 (1 each) . . . . . 2144100188

Plate guide S2 (1 each) . . . . . 2144100189

Plate guide S3 (1 each) . . . . . 2144100193

Plate guide S4 (1 each) . . . . . 2144100194



Information about replacement parts is available from the portal for authorised specialist dealers at:  
[www.duerrdental.net](http://www.duerrdental.net)

### 3.5 Wear parts and replacement parts

**Image plates**

VistaScan IQ pack S0  
VistaScan image plate IQ S0 (2 x) +  
VistaScan light protection cover  
Plus S0 (1000 x) . . . . . 2130106051

VistaScan IQ pack S1  
VistaScan image plate IQ S1 (2 x) +  
VistaScan light protection cover  
Plus S1 (1000 x) . . . . . 2130106151

VistaScan IQ pack S2  
VistaScan image plate IQ S2 (2 x) +  
VistaScan light protection cover  
Plus S2 (1000 x) . . . . . 2130106251

VistaScan IQ Pack S3  
Image Plate IQ S3 (2 each)  
Light protection cover Plus S3  
(1000 each) . . . . . 2130106351

VistaScan IQ Pack S4  
Image Plate IQ S4 (1 each)  
Light protection cover Plus S4  
(100 each) . . . . . 2130106451

VistaScan IQ image plate S0  
(2x) . . . . . 2130104050

VistaScan IQ image plate S1  
(2x) . . . . . 2130104150

VistaScan IQ image plate S2  
(4x) . . . . . 2130104250

VistaScan IQ image plate S2  
(12x) . . . . . 2130104255

VistaScan IQ image plate S3  
(2x) . . . . . 2130104350

## 4 Technical data

### 4.1 Image plate scanner (XPS07.1D...)

Electrical data for the device		
Voltage	V DC	24
Max. current consumption	A	1.25
Output	W	< 30
Type of protection		IP20
Electrical data – power supply unit		
Nominal input voltage	V AC	100 - 240
Frequency	Hz	50/60
Nominal output voltage	V DC	24
Max. output current	A	1.25
General technical data		
Dimensions (W x H x D)	mm	211 x 249 x 258
	in	8.31 x 9.80 x 10.16
Weight	kg	approx. 5.1
	lb	approx. 11.24
Pixel size (selectable)	µm	12.5 - 50
Max. theoretical resolution	Line pairs/mm (Lp/mm)	approx. 40
Network connection		
LAN technology		Ethernet
Standard		IEEE 802.3u/IEEE 802.3ab
Data rate	Mbit/s	100/1000
Connector		RJ45
Type of connection		Auto MDI-X
Cable type		≥ CAT5e
Ambient conditions during operation		
Temperature	°C	+10 to +35
	°F	+50 to +95
Relative humidity	%	20 - 80
Air pressure	hPa	750 - 1060
Height above sea level	m	< 2000
	ft	< 6562

### Ambient conditions during storage and transport

Temperature	°C	-20 to 60
	°F	-4 to +140
Relative humidity	%	10 - 95
Air pressure	hPa	750 - 1060

### Classification

Medical Device Class (MDR)	I
Laser class (unit)	1
In accordance with IEC 60825-1:2014	

### Laser source

Laser class	3B	
In accordance with IEC 60825-1:2014		
Wavelength $\lambda$	nm	639
Output	mW	<12

### Technical data for the RFID module

Frequency	MHz	13.56
Modulation		ASK

### Electromagnetic compatibility (EMC)

#### Interference emission measurements

High-frequency emissions in accordance with CISPR 11	Group 1 Class B
Interference voltage at the power supply connection CISPR 11:2009+A1:2010	Compliant
Electromagnetic interference radiation CISPR 11:2009+A1:2010	Compliant

### Electromagnetic compatibility (EMC)

#### Interference immunity measurements on the cover

Immunity to electrostatic discharge IEC 61000-4-2:2008 ± 8 kV contact ± 2 kV, ± 4 kV, ± 8 kV, ± 15 kV air	Compliant
Immunity to high-frequency electromagnetic fields IEC 61000-4-3:2006+A1:2007+A2:2010 3 V/m 80 MHz–2.7 GHz 80% AM at 1 kHz	Compliant
Immunity to near fields of wireless HF communication devices IEC 61000-4-3:2006+A1:2007+A2:2010 See immunity to interference table, near fields of wireless HF communication devices	Compliant

**Electromagnetic compatibility (EMC)****Interference immunity measurements on the cover**

Immunity to power frequency magnetic fields IEC 61000-4-8:2009 30 A/m 50 Hz or 60 Hz	Compliant
---	-----------

**Immunity to interference levels, near fields of wireless HF communication devices**

Radio service	Frequency band MHz	Test level V/m
TETRA 400	380 - 390	27
GMRS 460 FRS 460	430 - 470	28
LTE band 13, 17	704 - 787	9
GSM 800/900 TETRA 800 iDEN 820 CDMA 850 LTE band 5	800 - 960	28
GSM 1800 CDMA 1900 GSM 1900 DECT LTE band 1, 3, 4, 25 UMTS	1700 - 1990	28
Bluetooth WLAN 802.11 b/g/n RFID 2450 LTE band 7	2400 - 2570	28
WLAN 802.11 a/n	5100 - 5800	9

**Electromagnetic compatibility (EMC)****Interference immunity measurements supply input**

Immunity to interference, rapid transient bursts – AC voltage grid IEC 61000-4-4:2012 ± 2 kV 100 kHz repetition frequency	Compliant
Immunity to interference, surges IEC 61000-4-5:2005 ± 0.5 kV, ± 1 kV	Compliant

**Electromagnetic compatibility (EMC)  
Interference immunity measurements supply input**

Immunity to interference, line-conducted disturbances induced by high-frequency fields – AC voltage grid

IEC 61000-4-6:2013

3 V Compliant

0.15 - 80 MHz

6 V

ISM frequency bands

0.15 - 80 MHz

80 % AM at 1 kHz

Immunity to interference due to voltage dips, short interruptions and voltage variations

IEC 61000-4-11:2004

Compliant

**Electromagnetic compatibility (EMC)  
Interference immunity measurements SIP/SOP**

Immunity to interference, discharge of static electricity

IEC 61000-4-2:2008

± 8 kV contact Compliant

± 8 kV contact

± 2kV, ± 4 kV, ± 8 kV, ± 15 kV air

Immunity to interference, rapid transient bursts – I/O,

SIP/SOP ports

IEC 61000-4-4:2012

± 1 kV Compliant

± 1 kV

100 kHz repetition frequency

Immunity to interference, line-conducted disturbances

induced by high-frequency fields – SIP/SOP ports

IEC 61000-4-6:2013

3 V Compliant

0.15 - 80 MHz

6 V

ISM frequency bands

0.15 - 80 MHz

80 % AM at 1 kHz

Image plate cleaning wipes (10 pcs.) . . . . .	CCB351B1001
FD 333 forte wipes for quick-acting disinfection . . . . .	CDF333FW0150
FD 350 Classic disinfection wipes . . . . .	CDF35CA0140
FD 333 rapid surface disinfection . . . . .	CDF333C6150
FD 322 rapid surface disinfection . . . . .	CDF322C6150
FD 366 rapid disinfectant for sensitive surfaces . . . . .	CDF366C6150
ID 212 Instrument disinfection . . . . .	CDI212C6150
ID 212 forte Instrument disinfection . . . . .	CDI212F6150
ID 213 Instrument disinfection . . . . .	CDI213C6150

## 4.2 Image plate

### Classification

Medical Device Class (MDR)	Ila
----------------------------	-----

### Ambient conditions during operation

Temperature	°C	18 - 45
	°F	64 - 113
Relative humidity	%	< 80

### Ambient conditions during storage and transport

Temperature	°C	< 45
	°F	< 113
Relative humidity	%	< 80

### Dimensions of intraoral image plates

S0	mm	22 x 35
	in	0.87 x 1.38
S1	mm	24 x 40
	in	0.94 x 1.57
S2	mm	31 x 41
	in	1.22 x 1.61
S3	mm	27 x 54
	in	1.06 x 2.13
S4	mm	57 x 76
	in	2.24 x 2.99

## 4.3 Light protection cover

### Classification

Medical Device Class (MDR)	I
----------------------------	---

## 4.4 Type plate

The type plate is located on the rear of the device.

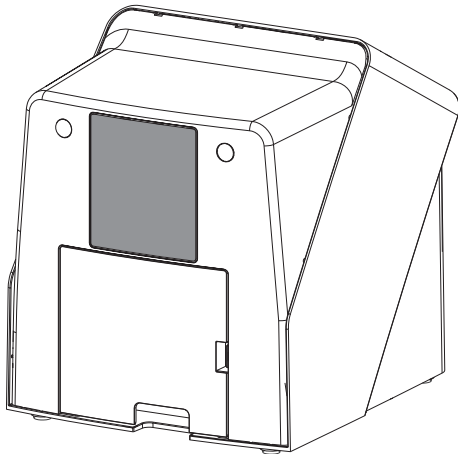

REF Order number

SN Serial number

## 4.5 Evaluation of conformity

This device has been subjected to conformity acceptance testing in accordance with the current relevant European Union guidelines. This equipment conforms to all relevant requirements.

## 4.6 Simplified declaration of conformity

The manufacturer hereby declares that the unit complies with Directive 2014/53/EU as well as others.

The full text of the EU declaration of conformity can be viewed online at the Download Center:



<https://qr.duerrdental.com/conformity>

# 5 Function

## 5.1 Image plate scanner

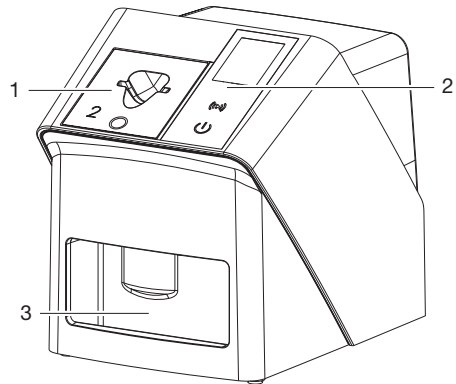

- 1 Plate guides:
- 2 User interface and display
- 3 Collection tray

The image plate scanner is used to read image data stored on an image plate and to transfer the data to the imaging software (e.g. VistaSoft) on a computer.

The transport mechanism guides the image plate through the device. The image plate is read using a laser inside the scanner unit. The scanned data is converted into a digital image and transferred to the imaging software.

After scanning, the image plate runs through the erasure unit. Image data still held on the image plate is erased with the aid of bright light. The image plate is then ejected for re-use.

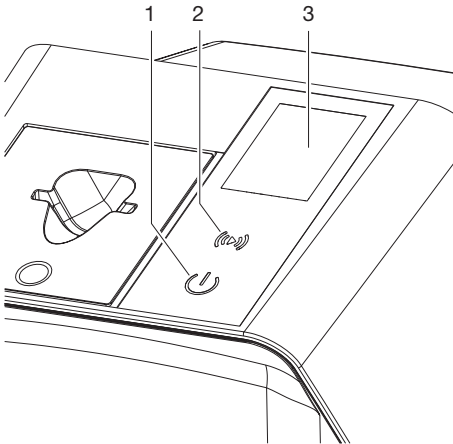

## Operating elements



- 1 On / off switch
- 2 Confirm button
- 3 Display

### On / off switch

The on / off switch shows different states of the unit:

-  Unit off  
To start simply press the on / off switch.
-  The unit switches on or is ready for use  
The start screen appears as soon as the unit can be used.

### Confirm button

The Confirm button is used to confirm messages on the display. The button flashes when a message requiring confirmation is displayed.

### Display

The display shows information provided by the imaging software.

## Connections

The connections are located on the rear of the unit, underneath the cover.

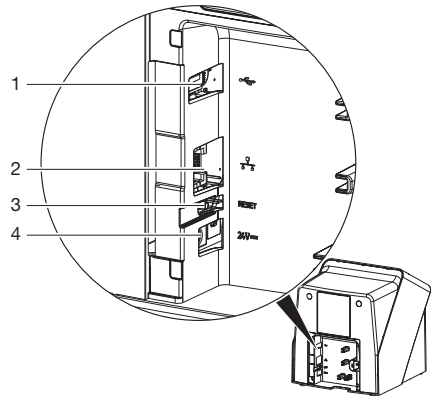

- 1 USB port (additional accessory)
- 2 Network connection
- 3 Reset button
- 4 Connection for power supply unit

## 5.2 Image plate

The image plate stores X-ray energy, which is re-emitted in the form of light after excitation via the laser. This light is then converted to image information in the image plate scanner.

The image plate has an active side and an inactive side. The image plate must always be exposed on the active side.

When used properly, image plates can be exposed, read and erased several hundred times provided there is no mechanical damage. The image plate must be replaced if there are any signs of damage, e.g. if the protective layer is damaged or there are visible scratches that could interfere with the diagnosis.

## Intraoral

Inactive side	Active side
	
<p>White, printed with the word "back" and the size and manufacturer's information</p>	<p>Light blue, with positioning aid </p>

The positioning aid  is visible on the X-ray image and makes it easier to align the image correctly during diagnosis.

 Use only IQ image plates with the unit. The unit is unable to read any other types of image plates.

### 5.3 Light protection cover

The light protection cover protects the image plate against light.

### 5.4 Protective cover

The protective cover protects the device against dust and dirt, e. g. during extended periods in which it is not in use.

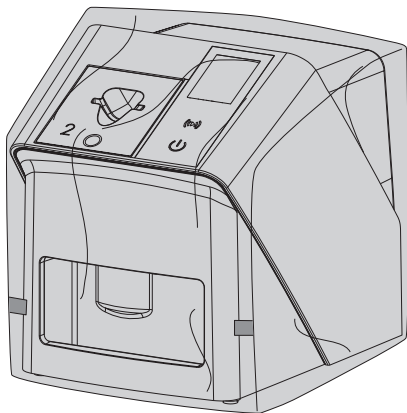

### 5.5 Image plate storage box

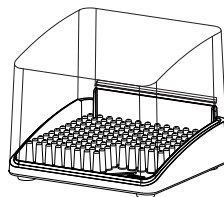
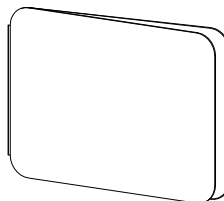



Image plates packed in light protection covers can be stored in the image plate storage box until the next use. The image plate storage box protects the image plate and the light protection cover against contamination and dirt.

### 5.6 Bite protector (optional)



The bite protector protects the image plate S4 as well as the light protection cover against heavy mechanical damage, e. g. If the patient bites down too hard during the X-ray exposure.

# Assembly

 Only qualified specialists or employees trained by Dürr Dental are permitted to install, connect and start using the unit.

## 6 Requirements

### 6.1 Installation/setup room

The room chosen for set up must fulfil the following requirements:

- Closed, dry, well-ventilated room
- It should not be a room made for another purpose (e.g. boiler room or wet cell).
- Max. light intensity 1000 Lux, no direct sunlight at the place of installation of the unit
- There should be no large fields of interference (e.g. strong magnetic fields) present that can interfere with the correct operation of the unit.
- Refer to the requirements for environmental conditions in "4 Technical data".

### 6.2 System requirements

 The system requirements for the computer systems can be found in the download area at [www.duerdental.com](http://www.duerdental.com) (document no. 9000-618-148).

### 6.3 Monitor

The monitor must comply with the requirements for digital X-ray with a high light intensity and wide contrast range. Strong ambient light, sunlight falling directly onto the monitor and reflections can make it harder or even impossible to perform a diagnosis based on the X-ray images.

## 7 Installation

### 7.1 Setting up the unit

 **NOTICE**  
**Risk of damage to sensitive components in the unit as a result of shocks or vibrations**

- › Do not expose the unit to any strong vibrations or shocks.
- › Do not move the unit during operation.

Portable and mobile HF communication appliances can interfere with the effectiveness of electrical medical devices.

1. Do not stack the unit next to or together with other appliances.
2. If, however, this unit is operated next to other units or stacked with other units, monitor the unit carefully in the configuration selected in order to ensure normal operation.

The unit can be set up as a tabletop unit or mounted on a wall using the wall bracket. The load-bearing capacity of the table or wall must be suitable for the weight of the unit (see "4 Technical data").

#### Setting the unit on a table

 To prevent errors when scanning the image data, install the unit so it is not exposed to vibrations.

1. Place the unit on a firm, horizontal surface.

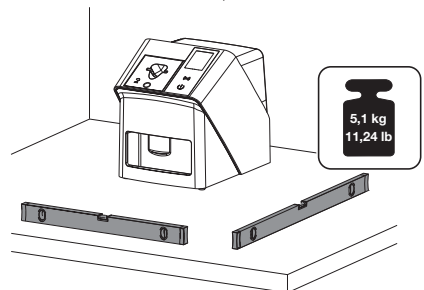

#### Installing the unit with the wall mounting bracket

The unit can be mounted on a wall with the wall mounting bracket (see "3.3 Optional items").

## 7.2 Electrical connections

### Safety when making electrical connections

1. The device must only be connected to a correctly installed power outlet.
2. Do not place non-fixed multi-socket units on the floor. Follow the requirements in section 16 of IEC 60601-1 (EN 60601-1).
3. Do not operate any other systems using the same multiple socket.
4. Make sure that none of the electrical cables leading to the unit are under any mechanical tension.
5. Before initial start-up check that the mains supply voltage and the voltage stated on the type plate match (see also "4. Technical data").

### Connecting the unit to the mains supply

 The unit has no main power switch. For this reason it is important that the unit is be set up in such a way that the plug can be easily accessed and unplugged if required.

Requirements:

- ✓ Properly installed power outlet close to the unit (observe the max. mains cable length)
- ✓ Easily accessible power outlet
- ✓ Mains voltage must match the information shown on the type plate of the power supply unit

 Only approved power supply units may be used:  
9000150006 EM1024KR or  
9000101790 TR30RDM240

1. Attach the matching country-specific adapter to the power supply unit.

2. Remove the cover from the back of the unit using a suitable tool (e.g. slotted-head screwdriver).

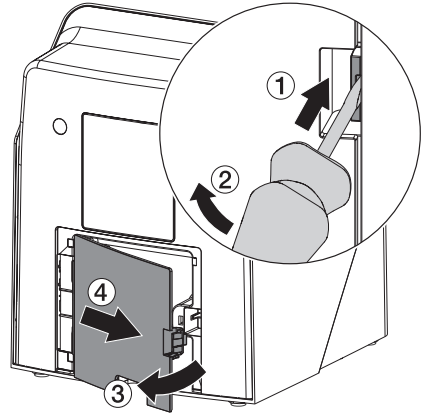

3. Plug in the connecting plug of the power supply unit into the socket connection of the device.

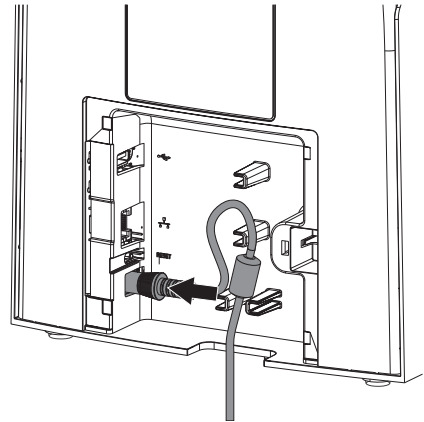

4. Plug the mains plug into the power outlet.

### 5. Refit the cover.

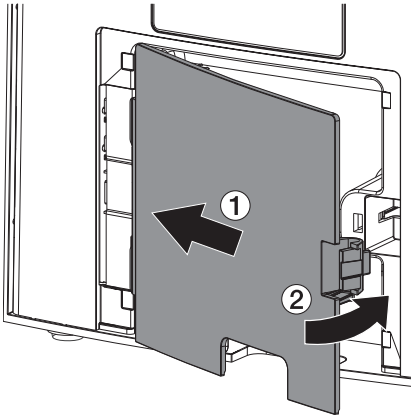

When operating the device, the rear side cover must be mounted.

## 7.3 Connecting the device to the network

The unit must be connected to a network for operation.

### Purpose of the network connection

The network connection is used to exchange information or control signals between the unit and a software installed on a computer, in order to, e. g.:

- Display parameters
- Select operating modes
- Indicate messages and error situations
- Change unit settings
- Activate test functions
- Transmit data for archiving
- Provide documents concerning the units

### Combining devices safely

- The overall safety of the unit and its main performance features are independent of the network. The device is designed for operation independent of a network. However, some of the functions are not available in this case.
- Incorrect manual configuration can lead to significant network problems. The expert knowledge of a network administrator is required for configuration.
- The data connection utilises part of the bandwidth of the network. Interactions with other medical devices cannot be completely ruled out. Apply the IEC 80001-1 standard for risk assessment.
- The device is not suitable for direct connection to the public Internet.

Take care when connecting units together or to parts of other systems as there is always an element of risk (e.g. due to leakage currents).

- Only connect units when there can be no question of danger to operator or to patient.
  - Only connect units when it is safe to do so and when there is no risk of damage or harm to the surroundings.
  - If it is not completely clear from the data sheet of the unit that such connections can be safely made or if you are in any doubt, always get a suitably qualified person (e.g. the relevant manufacturer) to verify that the setup is safe.
1. Observe the specifications of IEC 60601-1 (EN 60601-1) when connecting the appliance with other appliances, e.g. a PC system, both in and outside the patient environment.
  2. Only connect peripheral units (e. g. computer, monitor, printer) that conform at least to the requirements set out in IEC 60950-1 or IEC 62368-1.
  3. The connected computer must conform to EN 55032 (class B) and EN 55024.

### Connecting the unit via the network cable

1. Remove the cover from the back of the unit using a suitable tool (e.g. slotted-head screwdriver).

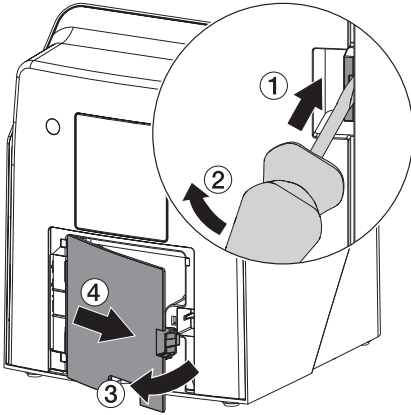

2. Connect the supplied network cable to the network connection of the device.

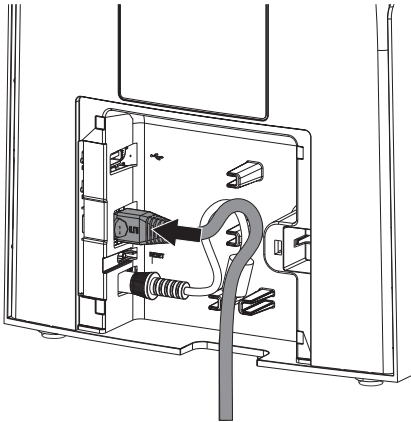

3. Refit the cover.

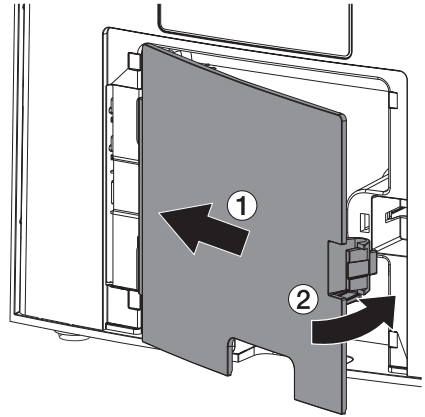

 When operating the device, the rear side cover must be mounted.

## 8 Commissioning



### NOTICE

#### Short circuit due to the build up of condensation

- › Do not switch on the unit until it has warmed up to room temperature and it is dry.

The unit supports the following imaging programs:

- VistaSoft from Dürr Dental
- VistaSoft Connect from Dürr Dental
- Third-party software on request



Always use the current version of the imaging program and VistaScan service tools.

### 8.1 Configuring the network

#### Network configuration

Various options are available for network configuration:

- ✓ Automatic configuration via DHCP.
  - ✓ Automatic configuration via Auto-IP for direct connection of unit and computer.
  - ✓ Manual configuration.
1. Configure the network settings of the unit using the software or, if applicable, the touch screen.
  2. Check the firewall and release the ports, if applicable.

#### Network protocols and ports



Port	Purpose	Service
1900 UDP	Device detection	
80 TCP	Device detection	
443 TCP	Device data	
22 TCP	Diagnosis	SSH
n/a	Check that the device is switched on	ICMP / ping



When the unit is first connected to a computer, it applies the language and time settings of the computer.

### 8.2 Configuring the unit

The VistaScan service tool is used to configure the unit.

1. Start the Service-Tool in VistaSoft:  
Select  > *Units* > *Configure* > *Maintenance* > *Service Tool*.  
: Start the service tool from the Windows Start menu:  
*Start* > *VistaScan Service Tool* > *VistaScan Service Tool*
2. Mark the connected unit in the list.  
 If the unit connected does not appear in the list, check that the unit is switched on and connected to the network. Then click *Find again*.
3. Click *OK*.  
If connecting fails, an error message appears.
4. Select *001 Initial commissioning* procedure.
5. Follow the instructions provided by the service tool.

#### Entering a permanent IP address (recommended)



To reset the network settings, keep the unit reset key pressed for 15 - 20 seconds while switching on.

1. Select *Network settings*.
2. Change *Use DHCP* to *off*.
3. Enter the IP address, subnet mask and gateway.
4. Click *Save changes*.  
The configuration is saved.

### 8.3 Security settings

Communication between the imaging software and the unit is always encrypted. On delivery, communication is protected by a standard password: 123456. For increased security, this password must be changed in the imaging software settings. For further information, see the manual for the imaging software.

## 8.4 Testing the device

You can scan in an X-ray image to check that the unit is properly connected.

1. Open VistaSoft.
2. Create an X-ray station for the connected unit.
3. Log-in the demo patient (patient ID: DEMO0001).
4. Select the image type (e. g. Intraoral).
5. Scan an image plate, see "10 Operation".

## 8.5 X-ray unit settings



If 60 kV can be set on the X-ray unit, this setting is preferred.

The standard exposure values for F-speed film (e. g. Kodak Insight) can be used.

The following table shows the standard values for the exposure time and the dose area product of an image plate for an adult patient.

The values of exposure time and dose area product are based on used of a VistalIntra as X-ray unit.

$\mu\text{Gy}$  = Image receiver dose

$\text{mGy}\text{cm}^2$  = Dose area product

	DC emitter, 7 mA, tube length 20 cm						
	Without X-ray field limitation			X-ray field limitation 2x3		X-ray field limitation 3x4	
	60 kV	$\mu\text{Gy}$	$\text{mGy}\text{cm}^2$	60 kV	$\text{mGy}\text{cm}^2$	60 kV	$\text{mGy}\text{cm}^2$
Incisors	0.08 s	459	14.6	0.08 s	3.1	0.08 s	6.2
Premolars	0.12 s	715	21.9	0.12 s	4.6	0.12 s	9.3
Molars	0.17 s	1021	31.1	0.17 s	6.6	0.17 s	13.2
Bitewing	0.18 s	1080	32.9	0.18 s	7.0	0.18 s	14

	DC emitter, 6 mA, tube length 30 cm						
	Without X-ray field limitation			X-ray field limitation 2x3		X-ray field limitation 3x4	
	70 kV	$\mu\text{Gy}$	$\text{mGy}\text{cm}^2$	70 kV	$\text{mGy}\text{cm}^2$	70 kV	$\text{mGy}\text{cm}^2$
Incisors	0.13 s	530	11.8	0.13 s	2.5	0.13 s	5.0
Premolars	0.18 s	730.8	16.4	0.18 s	3.4	0.18 s	6.9
Molars	0.25 s	1024	22.8	0.25 s	4.8	0.25 s	9.6
Bitewing	0.27 s	1107	24.6	0.27 s	5.2	0.27 s	10.4

1. Check and adjust the specific X-ray unit in accordance with the standard values.

## 8.6 Acceptance tests

The required tests (e.g. acceptance tests) must be carried out in accordance with local rules and regulations.

1. Find out which tests are required.
2. Carry out testing in accordance with local rules and regulations.

### Acceptance test



The Intra / Extra Digital test phantom is required for acceptance checks with the image plate and sensor as receivers, and possibly also the corresponding test phantom holder.

1. Before the unit is started up and used for the first time, the acceptance test of the X-ray system must be carried out in accordance with national regulations.  
The constancy tests, which must be carried out at regular intervals by the surgery personnel, are based on the results of the acceptance test.

### **Electrical safety checks**

1. Carry out the electrical safety check according to the national law (e. g. in accordance with IEC 62353).
2. Document the results.
3. Carry out and document the instruction and handover for the unit.



A sample handover report is included in the attachment.



## 9 Correct use of image plates



### WARNING

**Risk of cross contamination when not using the light protection cover or when using the light protection cover more than once**

- › Do not use an image plate without a light protection cover.
- › Do not use the light protection cover more than once (disposable item).



### CAUTION

**The image data on the image plate is not permanent.**

The image data is altered by light, natural X-ray radiation and scattered X-ray radiation. This will lead to a reduction in diagnostic information and clarity.

- › Read the image data within 30 minutes of exposure.
- › Never handle exposed image plates without the light protection cover.
- › Do not subject an exposed image plate to X-ray radiation before or after the scanning process. Do not X-ray during the scanning process if the unit is in the same room as the X-ray tube.
- › Image plates must only be read using an image plate scanner that is approved by Dürre Dental.



### CAUTION

**Image plates are toxic**

Image plates that are not packed in a light protection cover can lead to poisoning when placed in the mouth or swallowed.

- › Only place image plates in the patient's mouth in a light protection cover.
- › Do not swallow the image plate or parts of it.
- › If the image plate or parts of it have been swallowed, consult a specialist doctor immediately and remove the image plate.
- › If the light protection cover has been damaged in the patient's mouth, rinse the mouth thoroughly with lots of water. Do not swallow the water in the process.

1. Image plates are flexible like X-ray film. However, the image plates should not be bent.

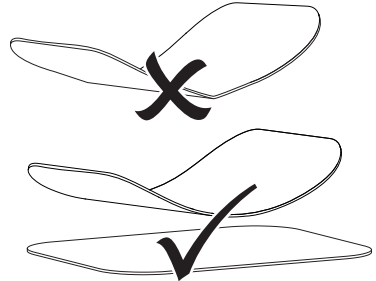

2. Do not scratch the image plates. Do not subject the image plates to pressure from hard or pointed objects.

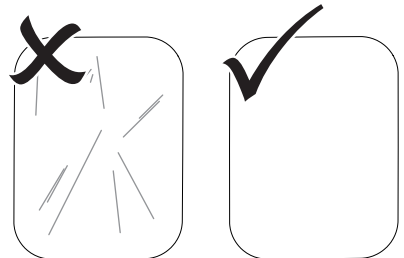

3. Do not soil the image plates.

4. Protect the image plates against sunlight and ultraviolet light.  
Store image plates in a light protection cover or intraoral/extraoral foil cassette of the correct size.
5. Image plates will be pre-exposed on exposure to natural radiation and stray x-ray radiation. Protect erased and exposed image plates from X-ray interference.  
If the image plate has been stored for longer than one week, erase the image plate prior to use.
6. Do not store image plates under hot or moist conditions. Observe the correct ambient conditions (see "4 Technical data").
7. When used properly, image plates can be exposed, read and erased several hundred times provided there is no mechanical damage.  
Replace the image plate if there are any signs of damage, e.g. if the protective layer is damaged or there are visible scratches that impair the quality of the diagnosis.  
Also replace the image plate if the RFID tag is damaged or becoming detached.
8. Image plates that have a production or packaging defect will be replaced by Dürr Dental in the same quantity. Claims can only be accepted within 7 working days after receipt of the goods.
9. Clean image plates properly (see "11 Cleaning and disinfection").

## 10 Operation



### CAUTION

**The image data on the image plate is not permanent.**

The image data is altered by light, natural X-ray radiation and scattered X-ray radiation. This will lead to a reduction in diagnostic information and clarity.

- › Read the image data within 30 minutes of exposure.
- › Never handle exposed image plates without the light protection cover.
- › Do not subject an exposed image plate to X-ray radiation before or after the scanning process. Do not X-ray during the scanning process if the unit is in the same room as the X-ray tube.
- › Image plates must only be read using an image plate scanner that is approved by Dürr Dental.

### 10.1 Switch on the unit

1. Switch on the unit by tapping the on / off switch .

The on / off switch lights up briefly and the unit starts.

As soon as the unit is ready for operation, the on/off switch lights up blue and the start screen is displayed.

## 10.2 Changing the plate guide

The unit can read S0 to S4 image plates. Each size of image plate requires the matching plate guide.

The size of the image plate is marked on the plate guide.

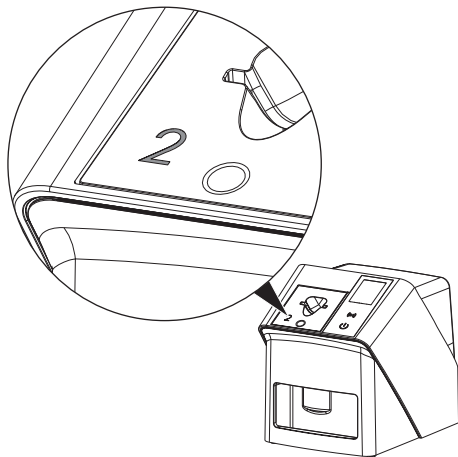

The plate guide can be changed at any time. To avoid loss of image quality, do not change the plate guide during a scan.

1. Press your finger into the recess and at the same time tilt the plate guide forwards.

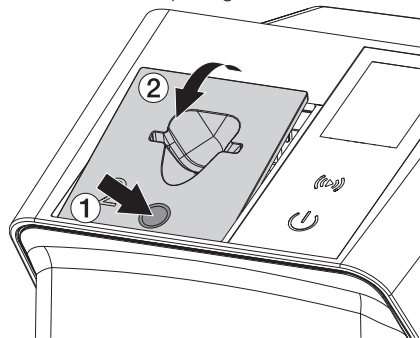

2. Insert the plate guide from above.





### CAUTION

**Loss of image information and equipment damage if an incorrect plate guide is used**

- › Always use the correct size of plate guide for the image plate being used.
- › Before each scanning process, compare the image plate size with the markings on the plate guide.

### 10.3 X-ray

 The procedure is described using an IQ S2 image plate as an example.

 Use only IQ image plates with the unit. The unit is unable to read any other types of image plates.

Required accessories:

- Image plate
- Light protection cover the same size as the image plate



**WARNING**

**Risk of cross contamination when not using the light protection cover or when using the light protection cover more than once**

- › Do not use an image plate without a light protection cover.
- › Do not use the light protection cover more than once (disposable item).



**WARNING**

**Danger due to re-use of products intended for single use**

The disposable item is damaged after use and cannot be reused.

- › Dispose of disposable items after use.

#### Preparing the X-ray

- ✓ The image plate has been cleaned.
- ✓ The image plate is not damaged.
- ✓ The adhesive film adheres to the inactive side of the image plate. If the adhesive film peels off, replace the image plate.

1. If using it for the first time or if it has been stored for over a week: erase the image plate (see "10.5 Erasing the image plate").

2. Completely slide the image plate into the light protection cover. The white (inactive) side of the image plate must be visible.

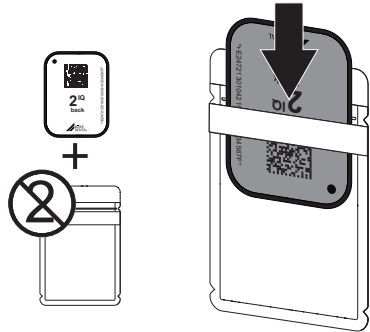

3. Pull off the adhesive strip, fold down the flap and close the light protection cover tightly by pressing together firmly.

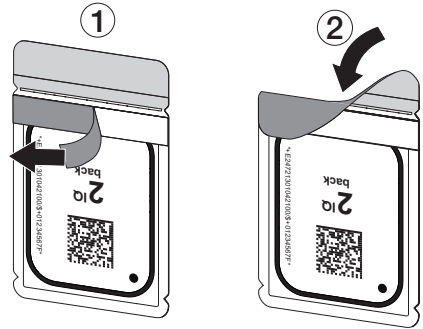

4. The light protection cover must be disinfected using a suitable disinfectant wipe immediately before positioning it inside the patient's mouth (see "3.4 Consumables").

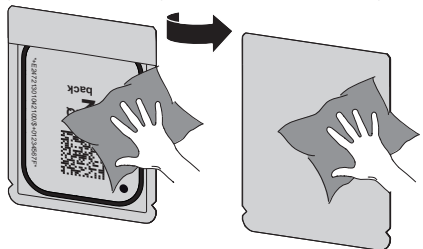

5. Allow the light protection cover to fully dry.

## Taking the X-ray image



### NOTICE

#### Damage to the image plate caused by a sharp-edged holding system

- › Only use holding systems that will not damage the light protection cover or the image plates in any way.
- › Do not use holding systems with sharp edges.



Wear protective gloves.

1. Place the image plate in the light protection cover into the patient's mouth. When doing this, make sure that the active side of the image plate points towards the X-ray tube.

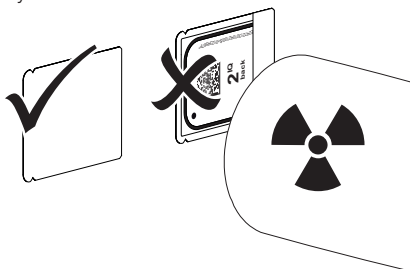

2. Set the exposure time and setting values on the X-ray unit (see "8.5 X-ray unit settings").
3. Record an X-ray image.  
The image data must be scanned within 30 minutes.

## Preparing for scanning



### CAUTION

#### Light erases the image data on the image plate

- › Never handle exposed image plates without the light protection cover.



Wear protective gloves.

1. Remove the image plate with the light protection cover from the patient's mouth.



### WARNING

#### Contamination of the unit

- › Clean and disinfect the light protection cover before removing the image plate.
2. In the event of heavy soiling, e.g. from blood, dry clean the light protection cover and protective gloves, e.g. wipe with a clean cellulose cloth.
  3. Disinfect the light protection cover and protective gloves with a suitable disinfection wipe; see "11.2 Light protection cover".

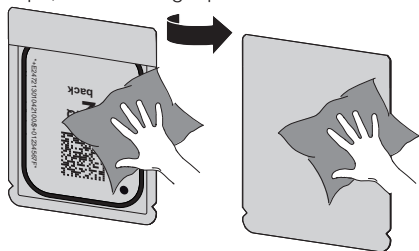

4. Allow the light protection cover and image plate to dry completely.
5. Pull off the protective gloves and disinfect the hands.



### NOTICE

#### Powder from the protective gloves on the image plate can damage the unit during scanning

- › Completely clean all traces of the protective glove powder from your hands before handling the image plate.

6. Tear off the light protection cover.



## 10.4 Scanning the image data via a computer

### Starting the image plate scanner and software

**i** The reading-out process is described using the VistaSoft imaging software. For further information on using the imaging software, refer to the relevant manual.

1. Start VistaSoft.
2. Select the patient.
3. Select the corresponding image type in the menu bar.
4. Select the device.
5. Set acquisition mode.  
Recording starts directly.

The unit will display an animated visual symbol requesting insertion of the image plate.

**i** Only insert the image plate when the bar above the animated sequence has turned to green.  
Do not insert any more imaging plates as long as the animation bar is blue.

### Scanning the image plate

**i** Heed the information on the display. When inserting the image plate, make sure that it is assigned to the correct patient.

1. Place the light protection cover with the image plate centrally and straight onto the plate guide. The opened side of the light protection cover faces down, the inactive side of the image plate faces the operator.

**i** The unit automatically detects if the image plate has been inserted the wrong way round (active side towards the operator) and a message to this effect appears on the display. Turn the image plate over (inactive side towards the operator) and re-insert it immediately.

The image plate must not be pushed out of the light protection cover before it has been placed on the plate guide. There is the risk of image information being erased by ambient light (see "9 Correct use of image plates").

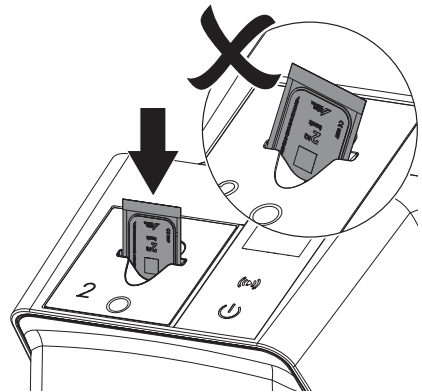

- Slide the image plate out of its light protection cover downwards into the device until the image plate is automatically drawn in.

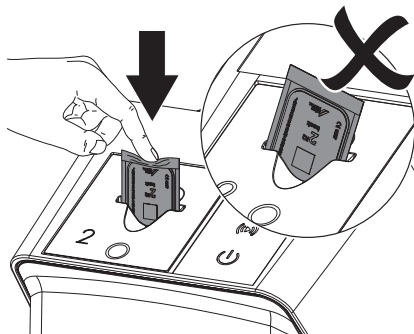

The light protection cover is held in place by the plate guide and is not drawn into the unit.

Make sure that only the image plate, and not the light protection cover, is inserted into the unit.

The image data is automatically transmitted to the imaging software.

After it has been scanned, the image plate is erased and drops into the collection tray.

- Remove the empty light protection cover.
- Remove the image plate and prepare it for taking a new X-ray.

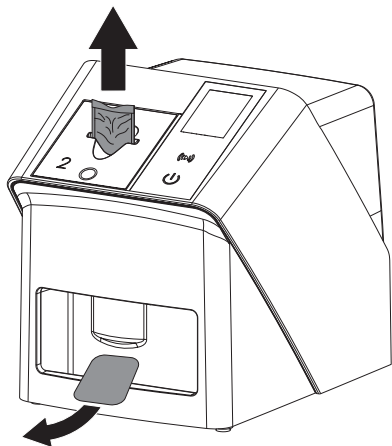

- If necessary, read in additional image plates. When you have finished the last image plate, click *Finish imaging*.

## 10.5 Erasing the image plate

The image data is automatically erased after scanning.

The special **ERASE** mode only activates the erasure unit of the image plate scanner. No image data is read.

The image plate needs to be erased using the special mode in the following cases:

- The first time the image plate is used, or if it is stored for longer than a week.
- Due to an error, the image data on the image plate has not been erased (software error message).

- Select the special **ERASE** mode in the software.
- Insert the image plate (see "Scanning the image plate").

## 10.6 Switch off the unit.

- Switch off the unit by tapping the on / off switch .

The on / off switch lights up briefly and the unit shuts down.

As soon as the unit has shut down it switches off completely.



After you switch off the unit, wait 10 s before switching the unit on again.

- In the event of an error, a hard shutdown of the unit can be performed. To perform a hard shutdown, press and hold the on / off switch  for about 5 seconds.

The unit switches off immediately.

### Using the protective cover

The protective cover protects the device against dirt and dust during extended periods in which it is not used.



#### WARNING

#### Danger of suffocation

- › Store the protective cover out of the reach of children.

1. Pull the protective cover over the device so that it is completely covered. Make sure that the markings are at the front.

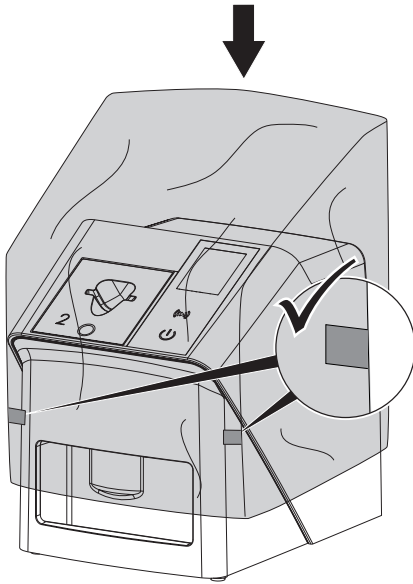

2. Store the protective cover in a safe place when it is not in use.

## 11 Cleaning and disinfection

When cleaning and disinfecting the unit and its accessories, observe country-specific directives, standards and specifications for medical products as well as the specific specifications for dental practices and clinics.



### NOTICE

**The use of unsuitable agents and methods can damage the unit and accessories.**

Do not use any products based on phenolic compounds, halogen-releasing compounds, strong organic acids or oxygen-releasing compounds, as they may damage the materials.

- › Dürr Dental recommends using disinfectants from the Dürr Dental product range. Only the products specified in these instructions have been subjected to material compatibility testing by Dürr Dental.
- › Read the operating instructions for the disinfectants.



Wear protective gloves.

### 11.1 Image plate scanner

#### Unit surfaces



The plate guide must be removed prior to cleaning and disinfection (see "10.2 Changing the plate guide").

For cleaning and disinfecting the plate guide, see "Plate guides:".

The unit surface must be cleaned and disinfected of any contamination or visible soiling.

Dürr Dental recommends using the disinfectants FD 322, FD 333, FD 350 and FD 366 sensitive.



### NOTICE

**Liquid can cause damage to the unit.**

- › Do not spray the unit with cleaning and disinfectant agents.
- › Make sure that liquid does not get inside the unit.

1. Remove any soiling with a soft, lint-free cloth that has been dampened with cold tap water.
2. Disinfect the surfaces using a disinfection wipe. Alternatively, use disinfectant on a soft, lint-free cloth.

#### Plate guides:

The plate guide must be cleaned and disinfected if there are indications of contamination or visible dirt.

The plate guide can be cleaned and disinfected with disinfectant wipes.

Dürr Dental recommends the disinfectants FD 322, FD 333, FD 350 and FD 366 sensitive. Alternatively, the foil cassette can also be disinfected in an immersion disinfection system.

For immersion disinfection, Dürr Dental recommends ID 212 Instrument Disinfectant and ID 213 Instrument Disinfectant



#### NOTICE

**Heat can damage plastic parts.**

- › Do not use a thermal disinfectant or steam steriliser on any parts of the device.

1. Remove the plate guide (see "10.2 Changing the plate guide").
2. Clean the plate guide with a soft, lint-free cloth that has been moistened with cold tap water.
3. Disinfect the plate guide using a disinfection wipe. Alternatively, use disinfectant on a soft, lint-free cloth. Comply with the operating instructions for the disinfectant when doing this.  
The plate guide can also be disinfected in an immersion disinfection system.
4. Insert the plate guide from above.

## 11.2 Light protection cover

The surface of the unit must be cleaned and disinfected if it is contaminated or visibly soiled.

1. Disinfect the light protection cover using a disinfectant before and after placement. Dürr Dental recommends FD 333 forte wipes (virucidal), FD 350 (limited virucidal activity) and FD 322 premium wipes (limited virucidal activity).
2. Allow the light protection cover to completely dry before using it.

## 11.3 Image plate

Cleaning and disinfection wipes are unsuitable for cleaning image plates and may cause damage to them.

Only use a cleaning agent that is compatible with the materials:

Dürr Dental recommends the image plate cleaning wipe (see "3.4 Consumables"). Only this product has been subjected to material compatibility testing by Dürr Dental.



#### NOTICE

**Heat or humidity will damage the image plate.**

- › Do not steam sterilise the image plate.
- › Do not immersion-disinfect the image plate.
- › Only use cleaning agents that are compatible with the materials.

1. Soiling on both sides of the image plate should be cleaned off with a soft, lint-free wipe prior to every use.
2. Remove resistant or dried on dirt with the image plate cleaning wipe. When doing this, observe the instructions for use for the cleaning wipe.
3. Allow the image plate to completely dry before using it.

## 11.4 Protective cover

Clean the surface of the protective cover if it is obviously dirty.

1. Clean the protective cover with a soft, lint-free cloth that has been moistened with cold tap water.

2. Only fit the protective cover to a unit that has been cleaned and disinfected.

## 11.5 Image plate storage box

Clean and disinfect the surface of the image plate storage box and the internal image plate storage tray in the event of contamination or visible soiling.

Dürr Dental recommends the following disinfectants for the image plate storage box:  
FD 366 sensitive

Dürr Dental recommends the following disinfectants for the image plate storage tray:  
FD 350 and FD 366 sensitive

1. Clean the surface of the image plate storage box and the image plate storage tray with a soft, lint-free cloth that has been dampened with cold tap water.
2. Disinfect the surfaces of the image plate storage box using a disinfection wipe. Alternatively, use disinfectant on a soft, lint-free cloth.
3. Disinfect the image plate storage tray using a disinfection wipe.  
Alternatively, the image plate storage tray can also be treated in a thermal disinfectant or steam steriliser. Do not exceed a temperature of 134°C when doing this.

## 12 Maintenance

### 12.1 Recommended maintenance schedule



Only trained specialists or personnel trained by Dürr Dental may service the device.





Prior to working on the unit or in case of danger, disconnect it from the mains.

Maintenance interval	Maintenance work
Annually	› Visually inspect the device.
	› Check the image plates for signs of scratches and change if necessary.
	› Check the belt drives, transport belts and springs, and replace if necessary.
	› Remove dust and dirt from accessible parts.
	› Carry out a system check.
Every 3 years	› Change the light protection brushes.
	› Change the roller fixtures.
	› Change the drive belt.

# ? Troubleshooting





## 13 Tips for operators and service technicians

 Any repairs exceeding routine maintenance may only be carried out by qualified personnel or our service.

 Prior to working on the unit or in case of danger, disconnect it from the mains.

### 13.1 Poor X-ray image

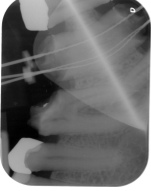
Error	Possible cause	Remedy
<b>Instead of the X-ray image, the software shows a completely white image or no image</b>	Image plate not fed in straight and inactive side scanned	<ul style="list-style-type: none"> <li>› Scan the image plate again immediately, protecting it against ambient light and making sure you feed it in correctly in the process.</li> </ul>
	Image data on the image plate has been erased, e.g. by ambient light	<ul style="list-style-type: none"> <li>› Always scan the image data of the image plate as quickly as possible.</li> </ul>
	Fault on the unit	<ul style="list-style-type: none"> <li>› Inform a Service Technician.</li> </ul>
	No image data on image plate, image plate not exposed or not sufficiently exposed	<ul style="list-style-type: none"> <li>› X-ray tubes / check unit settings</li> <li>› Expose the image plate.</li> </ul>
	X-ray unit is faulty	<ul style="list-style-type: none"> <li>› Inform a Service Technician.</li> </ul>
	Incorrect cartridge, light protection cover was also pushed into the unit	<ul style="list-style-type: none"> <li>› Use the correct cartridge for the size of image plate being used.</li> </ul>
<b>X-ray image too dark</b>	X-ray dose too high	<ul style="list-style-type: none"> <li>› Check X-ray parameters.</li> </ul>
	Incorrect brightness/contrast settings in the software	<ul style="list-style-type: none"> <li>› Adjust the brightness of the X-ray image in the software.</li> </ul>
<b>X-ray image too bright</b>	Exposed image plate has been exposed to ambient light	<ul style="list-style-type: none"> <li>› Always scan the image data of the image plate as quickly as possible.</li> </ul>
	X-ray dose too low	<ul style="list-style-type: none"> <li>› Check X-ray parameters.</li> </ul>
	Incorrect brightness/contrast settings in the software	<ul style="list-style-type: none"> <li>› Adjust the brightness of the X-ray image in the software.</li> </ul>
<b>X-ray image only shadowy</b>	The X-ray dose on the image plate was insufficient	<ul style="list-style-type: none"> <li>› Increase X-ray dose.</li> </ul>
	Amplification (HV value) is set too low in the software	<ul style="list-style-type: none"> <li>› Increase amplification (HV value).</li> </ul>
	Unsuitable scanning mode selected	<ul style="list-style-type: none"> <li>› Select a suitable scanning mode.</li> </ul>
	The setting for the threshold value is too high	<ul style="list-style-type: none"> <li>› Reduce the threshold value.</li> </ul>

Error	Possible cause	Remedy
<p><b>Top or bottom bulge in the X-ray image</b></p> 	<p>Image plate fed in off-centre and at an angle</p>	<ul style="list-style-type: none"> <li>› Check the error code on the display.</li> <li>› Insert the image plate centrally and straight.</li> </ul>
<p><b>X-ray image is mirror-inverted</b></p>	<p>Image plate exposed on the wrong side.</p>	<ul style="list-style-type: none"> <li>› Insert the image plate correctly in the light protection cover.</li> <li>› Position the image plate correctly.</li> <li>› Heed the error message and manually mirror the X-ray image in the imaging software.</li> </ul>
<p><b>Ghosting or double exposure on X-ray image</b></p> 	<p>Image plate exposed twice</p> <p>Image plate not sufficiently erased</p>	<ul style="list-style-type: none"> <li>› Only expose the image plate once.</li> <li>› Check the erasure unit is working correctly.</li> <li>› Inform a service technician if the problem persists.</li> </ul>
<p><b>X-ray image mirrored in one corner</b></p> 	<p>Image plate bent during X-ray exposure</p>	<ul style="list-style-type: none"> <li>› Do not bend the image plate.</li> </ul>
<p><b>Shadow on the X-ray image</b></p> 	<p>Image plate removed from the light protection cover before scanning</p>	<ul style="list-style-type: none"> <li>› Do not handle image plates without a light protection cover.</li> <li>› Store the image plate in a light protection cover.</li> </ul>

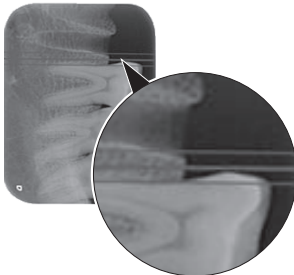
Error	Possible cause	Remedy
<b>X-ray image cut off, part missing</b>	The metal part of the X-ray tube is in front of the X-ray beam	<ul style="list-style-type: none"> <li>› When taking an X-ray, make sure there are no metal parts between the X-ray tube and the patient.</li> </ul>
	Faulty edge masking in imaging software	<ul style="list-style-type: none"> <li>› Check X-ray tube.</li> <li>› Deactivate edge masking.</li> </ul>
<b>Software unable to combine the data to make a complete image</b>	The X-ray dose on the image plate was insufficient	<ul style="list-style-type: none"> <li>› Increase X-ray dose.</li> </ul>
	Amplification (HV value) is set too low in the software	<ul style="list-style-type: none"> <li>› Increase amplification (HV value).</li> </ul>
	Unsuitable scanning mode selected	<ul style="list-style-type: none"> <li>› Select a suitable scanning mode.</li> </ul>
	The setting for the threshold value is too high	<ul style="list-style-type: none"> <li>› Reduce the threshold value.</li> </ul>
<b>X-ray image has strips on image</b>	Image plate has been pre-exposed, e.g. by natural radiation or stray X-ray radiation	<ul style="list-style-type: none"> <li>› If the image plate has been stored for longer than one week, erase the image plate prior to use.</li> </ul>
	Parts of image plate exposed to light during handling	<ul style="list-style-type: none"> <li>› Do not expose used image plates to bright light.</li> <li>› Scan image data within half an hour after the exposure.</li> </ul>
	Image plate dirty or scratched	<ul style="list-style-type: none"> <li>› Clean the image plate.</li> <li>› Replace scratched image plates.</li> </ul>
<b>Light strips in the scanning window</b>	Too much incident ambient light during the scanning process	<ul style="list-style-type: none"> <li>› Darken the room.</li> <li>› Turn the unit so that the light does not fall directly onto the input unit.</li> </ul>
<b>Horizontal, grey lines on the X-ray image, extending beyond the left and right image edge</b>	Transport slipping	<ul style="list-style-type: none"> <li>› Clean the transport mechanism, replace the transport belts if necessary.</li> </ul>
		

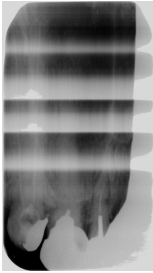
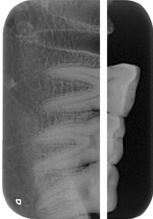
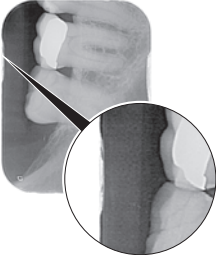
Error	Possible cause	Remedy
<p>X-ray image is stretched lengthwise with bright, horizontal stripes</p> 	<p>Incorrect light protection cover or image plate used</p>	<ul style="list-style-type: none"> <li>› Only use original accessories.</li> </ul>
<p>X-ray image split vertically into two halves</p> 	<p>Dirt in the laser slit (e.g. hair, dust)</p>	<ul style="list-style-type: none"> <li>› Clean the laser slit.</li> </ul>
<p>X-ray image with small bright spots or clouding</p>	<p>Micro scratches on the image plate</p>	<ul style="list-style-type: none"> <li>› Replace the image plate.</li> </ul>
<p>Lamination of the image plate becoming detached at the edge</p> 	<p>Incorrect retainer system used</p> <hr/> <p>Image plate handled incorrectly.</p>	<ul style="list-style-type: none"> <li>› Only use original image plates and film retainer systems.</li> <li>› Use the image plate correctly.</li> <li>› Observe the operating instructions for the image plates and film retainer systems.</li> </ul>

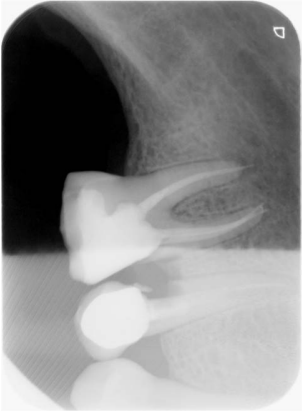
Error	Possible cause	Remedy
<p>The X-ray image shows a pre-erasure at one end</p> 	<p>After the barrier envelope has been torn off and before pushing the PSP into the input unit, the phosphor storage plate is pushed out of the light protection cover</p>	<ul style="list-style-type: none"> <li>› Do not push out the image plate until the torn-off light protection cover has been placed on the input unit.</li> </ul>

### 13.2 Software error

Error	Possible cause	Remedy
"Too much ambient light"	Unit exposed to too much light	<ul style="list-style-type: none"> <li>› Darken the room.</li> <li>› Turn the unit so that no light can fall directly into the entry slot.</li> </ul>
"Incorrect power supply unit"	Incorrect power supply unit connected	<ul style="list-style-type: none"> <li>› Use the supplied power supply unit.</li> </ul>
"Overtemperature"	Laser or erasure unit too hot	<ul style="list-style-type: none"> <li>› Switch off the unit and allow it to cool.</li> </ul>
"Erasure unit fault"	LED defective	<ul style="list-style-type: none"> <li>› Inform a Service Technician.</li> </ul>
Imaging software does not recognise the unit	Unit not switched on	<ul style="list-style-type: none"> <li>› Switch on the unit.</li> </ul>
	Connecting cable between device and computer not correctly connected	<ul style="list-style-type: none"> <li>› Check the connecting cable.</li> </ul>
	Computer does not detect any connection to the unit.	<ul style="list-style-type: none"> <li>› Check the connecting cable.</li> <li>› Check the network settings (IP address and subnet mask).</li> </ul>
	Hardware fault	<ul style="list-style-type: none"> <li>› Inform a Service Technician.</li> </ul>
	The IP address of the device is being used by another unit	<ul style="list-style-type: none"> <li>› Check the network settings (IP address and subnet mask) and assign a unique IP address to every device.</li> <li>› Inform a service technician if the problem persists.</li> </ul>

Error	Possible cause	Remedy
<b>Error during data transmission between unit and computer. Error message "CRC error timeout"</b>	Connecting cable used is incorrect or too long	<ul style="list-style-type: none"> <li>› Only use original cables.</li> </ul>
<b>Software message: "VistaSoft has detected that the image plate may have been exposed from the wrong side. Please check the orientation and the image quality before making a diagnosis."</b>	The image plate was exposed on the back (inactive) side while the X-ray was being taken.	<ul style="list-style-type: none"> <li>› When diagnosing the X-ray image, note that the X-ray image is displayed mirror-inverted.</li> </ul>
<b>"The selected unit cannot currently be accessed. Please check that the unit is switched on and correctly connected."</b>	Connection to the unit interrupted while the software was still attempting to communicate with the unit.	<ul style="list-style-type: none"> <li>› Restore the connection to the unit.</li> <li>› Repeat the process.</li> </ul>

### 13.3 Fault on the unit

Error	Possible cause	Remedy
<b>Unit does not switch on</b>	No mains voltage	<ul style="list-style-type: none"> <li>› Check the mains cable and plug connection and replace if necessary.</li> <li>› Check the power supply unit.</li> <li>› If the green status LED does not light up, replace the power supply unit.</li> <li>› Check the mains fuse in the building.</li> </ul>
	On / off switch is defective	<ul style="list-style-type: none"> <li>› Inform a Service Technician.</li> </ul>
	<b>Unit switches back off after a short time</b>	Mains cable or power supply unit plug not inserted correctly Hardware fault Mains supply voltage too low
<b>Unit not shown in the imaging software</b>	Network cable not installed	<ul style="list-style-type: none"> <li>› Install the network cable.</li> </ul>
	No DHCP server connected	<ul style="list-style-type: none"> <li>› It may take some time for the imaging software to detect the unit.</li> <li>› Update the unit list.</li> </ul>
	Network configuration incorrect	<ul style="list-style-type: none"> <li>› Configure the network correctly.</li> </ul>
<b>Unit is on, but there is nothing on the display</b>	Display initialisation fault	<ul style="list-style-type: none"> <li>› Switch the unit off and back on again.</li> </ul>
	Display defective	<ul style="list-style-type: none"> <li>› Inform a service technician.</li> </ul>
<b>Loud operating noises after switching on lasting more than 30 seconds</b>	Radiation deflector defective	<ul style="list-style-type: none"> <li>› Inform a Service Technician.</li> </ul>

Error	Possible cause	Remedy
<b>Unit not responding</b>	The unit has not yet completed the startup procedure	› After switching on, wait 20 - 30 seconds until the startup procedure has finished.
	Unit is blocked by the firewall	› Enable the ports for the unit in the firewall settings.
<b>Image plate does not fit into the intake slot</b>	Incorrect cartridge used	› Use the correct cartridge for the size of image plate being used.
<b>Light protection cover slips into intake slot together with image plate</b>	Incorrect cartridge used (too large)	› Use the correct cartridge for the size of image plate being used.
<b>Network connection has been disconnected</b>	WLAN stick not inserted	› Insert the WLAN stick into the unit.
	Distance to WLAN router too great	› Set up the unit closer to the WLAN router.
	Walls between WLAN router and unit too thick	› Set up the unit closer to the WLAN router.
	Another WLAN network is affecting the operation of the unit's WLAN network	› Change the frequency range of the WLAN network.
	Connecting cable between device and computer not correctly connected	› Check the connection cable.
	The IP address of the device is being used by another unit	› Check the network settings (IP address and subnet mask) and assign a unique IP address to every device. › Inform a service technician if the problem persists.
<b>Unit ejects the image plate without the image data being transmitted to the imaging software. Error message: "Incorrect image plate type inserted"</b>	Incorrect image plate guide used	› Use an approved image plate. The image was saved on the unit and can be imported into the imaging software via a network connection. › Connect the unit to the network. › Start the imaging software. › Start the image import via the imaging software (see software manual). › Save the image data. The image data on the unit is erased automatically as soon as the transfer has been successfully completed.

## 13.4 Error message on display

Error	Possible cause	Remedy
<b>Error code -1008</b>	Internal connection interrupted	<ul style="list-style-type: none"> <li>› Update the firmware.</li> </ul>
<b>Error code 1010</b>	Temperature of unit too high	<ul style="list-style-type: none"> <li>› Allow the unit to cool down.</li> <li>› Inform a Service Technician.</li> </ul>
<b>Error code 1022</b>	Subassembly not initialised	<ul style="list-style-type: none"> <li>› Fault in software, update the software if required.</li> <li>› Inform a Service Technician.</li> </ul>
<b>Error code 1024</b>	Internal data communication fault	<ul style="list-style-type: none"> <li>› Switch the unit off and back on again.</li> <li>› Update the firmware.</li> <li>› Darken the room.</li> <li>› Turn the unit so that no light can fall directly into the entry slot.</li> </ul>
<b>Error code 1026</b>	Incorrect acquisition mode	<ul style="list-style-type: none"> <li>› Select a different acquisition mode</li> <li>› Inform a Service Technician.</li> <li>› Update the firmware.</li> <li>› Reset the scanning modes to the factory settings via the unit interface or the Imaging Software.</li> </ul>
<b>Error code 1100</b>	Permitted time for scan process exceeded	<ul style="list-style-type: none"> <li>› Inform a Service Technician.</li> <li>› Check the belt drive.</li> <li>› Check for blockage, remove image plate from unit.</li> </ul>
<b>Error code 1153</b>	Unit fault	<ul style="list-style-type: none"> <li>› Switch the unit off and back on again.</li> <li>› Update the firmware.</li> </ul>
<b>Error code 1154</b>	Internal data communication fault	<ul style="list-style-type: none"> <li>› Switch the unit off and back on again.</li> <li>› Update the firmware.</li> </ul>
<b>Error code 1160</b>	Final radiation deflector rotation speed not attained	<ul style="list-style-type: none"> <li>› Inform a Service Technician.</li> <li>› Update the firmware.</li> <li>› Replace the radiation deflector subassembly if the problem occurs regularly.</li> </ul>
<b>Error code -1171</b>	Fault on laser	<ul style="list-style-type: none"> <li>› Send the unit for repair.</li> </ul>
<b>Error code 1172</b>	SOL sensor timeout Fault on the laser, SOL sensor or radiation deflector assembly	<ul style="list-style-type: none"> <li>› Inform a Service Technician.</li> <li>› Update the firmware.</li> </ul>
<b>Error code 10000</b>	Unit exposed to too much light	<ul style="list-style-type: none"> <li>› Darken the room.</li> <li>› Turn the unit so that no light can fall directly into the entry slot.</li> </ul>

Error	Possible cause	Remedy
<b>Error code 10009</b>	Internal communication error warning; unit remains ready for operation	› Update the firmware.
<b>Error code 10017</b>	Unit shutting down	› Wait until the unit has shut down completely.
<b>Error code -10022</b>	No plate guide or it has been removed	› Insert plate guide.
<b>Error code -10026</b>	Image plate inserted on the wrong side	› Insert the image plate with the inactive side facing the operator.
<b>Error code -10027</b>	Incorrect plate guide used	› Always use the correct plate guide for the image plate size.
<b>Error code -10028</b>	Incorrect or damaged image plate used	› Use an approved image plate or check the image plate for damage. The image plate has been erased.
<b>Error code -10030</b>	Incorrect or damaged image plate used	› Use an approved image plate or check the image plate for damage.  The image was saved on the unit and can be imported into the imaging software via a network connection. › Connect the unit to the network. › Start the imaging software. › Start the image import via the imaging software (see software manual). › Save the image data. The image data on the unit is erased automatically as soon as the transfer has been successfully completed.
<b>Error code 2</b>	System error during startup of the unit	› Switch the unit off and back on again. › Update the firmware.
<b>Error code -78</b>	Storage medium (e. g. memory card or memory stick) is full	› Transfer the image data to the computer. › Insert empty storage medium.
	Fault during memory cleanup	› Press and hold the reset button while switching on the unit.  › Update the firmware. › Press and hold the reset button while switching on the unit.

Error	Possible cause	Remedy
<b>Firmware not running</b>	A firmware update has been carried out.	› Switch the unit off and back on again.
	Internal communication fault	› Switch the unit off and back on again.
<b>Settings (e.g. language) reset after unit restart</b>	Faulty configuration file	› Update the firmware.
		› Reset the configuration to the factory settings and reconfigure.
<b>Warning message during shutdown of the unit</b>	Not a malfunction	› Update the firmware.

 Appendix

## 14 Scanning times

The scanning time corresponds to the time taken for complete scanning of image data and depends on image plate format and pixel size.

The time to image will depend largely on the computer system used and its work load. Times stated are approximate.

<b>Theoretical resolution (LP/mm)</b>	<b>40</b>	<b>25</b>	<b>20</b>	<b>10</b>	<b>6.7</b>
<b>Pixel size (µm)</b>	<b>12.5</b>	<b>20</b>	<b>25</b>	<b>50</b>	<b>50</b>
Intra S0 (2 x 3)	26 s	16 s	13 s	6 s	4 s
Intra S1 (2 x 4)	32 s	20 s	16 s	8 s	4 s
Intra S2 (3 x 4)	32 s	20 s	16 s	8 s	4 s
Intra S3 (2.7 x 5.4)	40 s	25 s	20 s	10 s	5 s
Intra S4 (5.7 x 7.6)	53 s	33 s	27 s	14 s	8 s

## 15 File sizes (uncompressed)

The actual file size will depend on the image plate format and the pixel size. File sizes stated are approximate and have been rounded upwards.

Suitable compression methods can considerably reduce the file size without loss of data.

<b>Theoretical resolution (LP/mm)</b>	<b>40</b>	<b>25</b>	<b>20</b>	<b>10</b>	<b>6.7</b>
<b>Pixel size (µm)</b>	<b>12.5</b>	<b>20</b>	<b>25</b>	<b>50</b>	<b>50</b>
Intra S0 (2 x 3)	9.86 MB	3.85 MB	2.46 MB	0.62 MB	0.62 MB
Intra S1 (2 x 4)	12.29 MB	4.80 MB	3.07 MB	0.77 MB	0.77 MB
Intra S2 (3 x 4)	16.27 MB	6.36 MB	4.07 MB	1.02 MB	1.02 MB
Intra S3 (2.7 x 5.4)	19.01 MB	7.43 MB	4.75 MB	1.19 MB	1.19 MB
Intra S4 (5.7 x 7.6)	55.45 MB	21.66 MB	13.86 MB	3.47 MB	3.47 MB

## 16 Handover record

This document confirms that a qualified handover of the medical device has taken place and that appropriate instructions have been provided for it. This must be carried out by a qualified adviser for the medical device, who will instruct you in the proper handling and operation of the medical device.

Product name	Order number (REF)	Serial number (SN)

- Visual inspection of the packaging for any damage
- Unpacking the medical device and checking for damage
- Confirmation of the completeness of the delivery
- Instruction in the proper handling and operation of the medical device based on the operating instructions

**Notes:**



**Name of person receiving instruction:**                      **Signature:**

**Name and address of the qualified adviser for the medical device:**

**Date of handover:**    **Signature of the qualified adviser for the medical device:**

--	--

## 17 Country representatives

Country	Address
GB	 <b>UK Responsible Person:</b> Duerr Dental (Products) UK Ltd. 14 Linnell Way Telford Way Industrial Estate Kettering, Northants NN 16 8PS
UA	 <b>Уповноважений представник в Україні:</b> Приватне підприємство “Галіт” вул. 15 квітня, 6Є, с. Байківці, Тернопільський р-н, 47711, Україна тел.: 0800 502 998; +38 050 338 10 64 <a href="http://www.galit.te.ua">www.galit.te.ua</a> ; e-mail: <a href="mailto:office@galit.te.ua">office@galit.te.ua</a>  Виробник: Дюрр Дентал ЕсЕ Хьолфігхаймер Штрассе 17, Д-74321 Бітігхайм-Біссінген, Німеччина email: <a href="mailto:info@duerrdental.com">info@duerrdental.com</a>







**Hersteller / Manufacturer:**

DÜRR DENTAL SE  
Höpfigheimer Str. 17  
74321 Bietigheim-Bissingen  
Germany  
Fon: +49 7142 705-0  
[www.duerrdental.com](http://www.duerrdental.com)  
[info@duerrdental.com](mailto:info@duerrdental.com)

