

VistaScan Mini Easy

EN



Installation and operating instructions



9000-618-210/02



1910V005

Contents



Important information

1	About this document	3
1.1	Warnings and symbols	3
1.2	Copyright information	4
2	Safety	4
2.1	Intended purpose	4
2.2	Intended use	4
2.3	Improper use	5
2.4	General safety information	5
2.5	Specialist personnel	5
2.6	Electrical safety	5
2.7	Essential performance characteristics	6
2.8	Notification requirement of serious incidents	6
2.9	Only use original parts	6
2.10	Transport	6
2.11	Disposal	6
2.12	Protection from threats from the Internet	6



Product description

3	Overview	8
3.1	Scope of delivery	9
3.2	Accessories	9
3.3	Optional items	9
3.4	Consumables	9
3.5	Wear parts and replacement parts	9
4	Technical data	11
4.1	Image plate scanner	11
4.2	Image plate	14
4.3	Light protection cover	15
4.4	Type plate	16
4.5	Evaluation of conformity	16
5	Operation	16
5.1	Image plate scanner	16
5.2	Image plate	17

5.3	Light protection cover	18
5.4	Protection cover	18
5.5	Storage box	18



Assembly

6	Requirements	19
6.1	Installation/setup room	19
6.2	System requirements	19
6.3	Monitor	19
7	Installation	19
7.1	Carrying the unit	19
7.2	Setting up the unit	19
7.3	Electrical connections	20
7.4	Connecting the unit	20
8	Commissioning	22
8.1	Set up the network (only with network connection)	22
8.2	Driver installation (USB port only)	23
8.3	Configuring the unit in VistaSoft	23
8.4	Configuring the appliance in DBSWIN	24
8.5	X-ray unit settings	26
8.6	Acceptance tests	27



Usage

9	Correct use of image plates	28
10	Operation	29
10.1	Changing the input unit cover	29
10.2	X-ray	29
10.3	Scanning the image data	31
10.4	Erasing the image plate	32
10.5	Switch off the unit	33
11	Cleaning and disinfection	33
11.1	Image plate scanner	33
11.2	Light protection cover	34
11.3	Image plate	34
11.4	Protection cover	35

- 11.5 Storage box with image plate storage tray 35
- 12 Maintenance 36**
 - 12.1 Recommended maintenance schedule 36



Troubleshooting

- 13 Tips for operators and service technicians 37**
 - 13.1 Poor X-ray image 37
 - 13.2 Software error 41
 - 13.3 Fault on the unit 42



Appendix

- 14 Scanning times 44**
- 15 File sizes (uncompressed) 45**
- 16 Handover record 46**

! Important information

1 About this document

These installation and operating instructions represent part of the unit.



If the instructions and information in these installation and operating instructions are not followed, Dürr Dental will not be able to offer any warranty or assume any liability for the safe operation and the safe functioning of the unit.

The German version of the installation and operating instructions is the original manual. All other languages are translation of the original manual. These operating instructions are valid for VistaScan Mini Easy, order number: 2143-000-60 and VistaScan Mini Easy (China version), order number: 2143-000-54.

1.1 Warnings and symbols

Warnings

The warnings in this document are intended to draw your attention to possible injury to persons or damage to machinery.

The following warning symbols are used:



General warning symbol



Warning – dangerous high voltage



Warning - laser beam

The warnings are structured as follows:



SIGNAL WORD

Description of the type and source of danger

Here you will find the possible consequences of ignoring the warning

- Follow these measures to avoid the danger.

The signal word differentiates between four levels of danger:

- **DANGER**
Immediate danger of severe injury or death
- **WARNING**
Possible danger of severe injury or death
- **CAUTION**
Risk of minor injuries
- **NOTICE**
Risk of extensive material/property damage

Other symbols

These symbols are used in the document and on or in the unit:



Note, e.g. specific instructions regarding efficient and cost-effective use of the unit.



Order number



Serial number



Medical device



Health Industry Bar Code (HIBC)



Lot designation



CE labelling



CE labelling with the number of the notified body



Manufacturer



Dispose of correctly in accordance with EU Directive 2012/19/EU (WEEE).



Refer to the accompanying electronic documents.



Please read all of the accompanying documents.



Refer to Operating Instructions.



Wear protective gloves.



Disconnect all power from the unit.



Do not reuse



DC current



This way up / store and transport in an upright position



Keep dry



Stacking limits



Fragile, handle with care



Keep away from sunlight

1.2 Copyright information

All circuits, processes, names, software programs and units mentioned in this document are protected by copyright.

The Installation and Operating Instructions must not be copied or reprinted, neither in full nor in part, without written authorisation from Dürr Dental.

2 Safety

Dürr Dental has designed and constructed this unit so that when used properly and for the intended purpose it does not pose any danger to people or property.

Despite this, the following residual risks can remain:

- Personal injury due to incorrect use/misuse
- Personal injury due to mechanical effects
- Personal injury due to electric shock
- Personal injury due to radiation
- Personal injury due to fire
- Personal injury due to thermal effects on skin
- Personal injury due to lack of hygiene, e.g. infection

2.1 Intended purpose

VistaScan Mini Easy

The unit is intended exclusively for use in dental applications for the scanning and processing of image data on an image plate.

Light protection cover

The functions of the Light Protection Cover are:

- to protect the image plate from light and therefore against accidental erasure
- to protect against cross-contamination

2.2 Intended use

VistaScan Mini Easy

The unit may only be operated using accessories and optional articles manufactured by or branded with Dürr Dental.

The unit may only be cleaned using the disinfectants and cleaning agents approved by and specified by the manufacturer.

Light protection cover

The Light Protection Cover is a disposable item. The Light Protection Cover is designed exclusively for use with image plate scanners manufactured by or branded with Dürr Dental and image plates manufactured by or branded with Dürr Dental.

2.3 Improper use

Any use of this appliance / these appliances above and beyond that described in the Installation and Operating Instructions is deemed to be incorrect usage. The manufacturer cannot be held liable for any damage resulting from incorrect usage. The operator will be held liable and bears all risks.

VistaScan Mini Easy

This unit is not suitable for monitoring patients over longer periods of time.

This unit must not be operated in operating theatres or similar rooms, in which dangers may arise from the combustion of flammable materials.

Light protection cover

Especially: The multiple use of this accessory and reprocessing contrary to the instructions of the manufacturer.

The use of the accessory in combination with other than image plate scanners manufactured by or branded with Dürr Dental and image plates manufactured by or branded with Dürr Dental.

2.4 General safety information

- › Always comply with the specifications of all guidelines, laws, and other rules and regulations applicable at the site of operation for the operation of this unit.
- › Check the function and condition of the unit prior to every use.
- › Do not convert or modify the unit.
- › Comply with the specifications of the Installation and Operating Instructions.
- › The Installation and Operating Instructions must be accessible to all operators of the unit at all times.

2.5 Specialist personnel

Operation

Unit operating personnel must ensure safe and correct handling based on their training and knowledge.

- › Instruct or have every user instructed in handling the unit.

Installation and repairs

- › Installation, readjustments, alterations, upgrades and repairs must be carried out by Dürr Dental or by qualified personnel specifically approved and authorized by Dürr Dental.

2.6 Electrical safety

- › Comply with all the relevant electrical safety regulations when working on the unit.
- › Never touch the patient and unshielded plug connections on the device at the same time.
- › Replace any damaged cables or plugs immediately.

Observe the EMC rules concerning medical devices

- › The unit is intended for use in professional healthcare facilities (in accordance with IEC 60601-1-2). If the appliance is operated in another environment, potential effects on electromagnetic compatibility must be taken into account.
- › Do not operate the unit in the vicinity of HF surgical instruments or MRT equipment.
- › Maintain a minimum distance of at least 30 cm between the unit and other electronic devices.
- › Keep a minimum distance of 30 cm between the unit and mobile radio devices.
- › Note that cable lengths and cable extensions have effects on electromagnetic compatibility.
- › No maintenance measures are required to maintain the EMV basic safety.



NOTICE

Negative effects on the EMC due to non-authorised accessories

- › Use only Dürr Dental parts or accessories specifically approved by Dürr Dental.
- › Using any other accessories may result in increased electromagnetic interference emissions or the unit having reduced electromagnetic immunity, leading to an erroneous operation mode.



NOTICE

Erroneous operation mode due to use immediately adjacent to other devices or with other stacked devices

- › Do not stack the unit together with other devices.
- › If this is unavoidable, the unit and other devices should be monitored in order to ensure that they are working correctly.

2.7 Essential performance characteristics

The VistaScan Mini Easy unit does not possess any significant performance characteristics as set out in IEC 60601-1 (EN 60601-1) section 4.3. The unit complies with the requirements according to IEC 60601-1-2:2014.

2.8 Notification requirement of serious incidents

The operator/patient is required to report any serious incident that occurs in connection with the device to the manufacturer and to the competent authority of the Member State in which the operator and/or patient is established/resident.

2.9 Only use original parts

- › Only use Dürr Dental parts or accessories and special accessories specifically approved by Dürr Dental.
- › Only use only original wear parts and replacement parts.



Dürr Dental accepts no liability for damages or injury resulting from the use of non-approved accessories or optional accessories, or from the use of non-original wear parts or replacement parts.

The use of non-approved accessories, optional accessories or non-genuine wear parts / replacement parts (e.g. mains cable) can have a negative effect in terms of electrical safety and EMC.

2.10 Transport

The original packaging provides optimum protection for the unit during transport. If required, original packaging for the unit can be ordered from Dürr Dental.



Dürr Dental will not accept any responsibility or liability for damage occurring during transport due to the use of incorrect packaging, even where the unit is still under guarantee.

- › Only transport the unit in its original packaging.
- › Keep the packing materials out of the reach of children.
- › Do not expose the unit to any strong vibrations or shocks.

2.11 Disposal



An overview of the waste keys for Dürr Dental products can be found in the download area at www.duerredental.com (document no. P007100155).

Unit



The unit must be disposed of properly. Within the European Union, the unit must be disposed of in accordance with EU Directive 2012/19/EU (WEEE).

- › If you have any questions about the correct disposal of parts, please contact your dental trade supplier.

Image plate

The image plate contains barium compounds.

- › Dispose of the image plate properly in accordance with the locally applicable regulations.
- › In Europe, dispose of the image plate in accordance with waste code 090199 "Wastes not otherwise specified". Disposal as domestic waste is possible.

2.12 Protection from threats from the Internet

The unit is to be connected to a computer that can be connected to the Internet. Therefore, the system needs to be protected from threats from the Internet.

- › Use antivirus software and update it regularly. Look for evidence of possible virus infection and, if applicable, check with the antivirus software and remove the virus.

- › Perform regular data backups.
- › Restrict access to units to trustworthy users, e.g. via a user name and password.
- › Make sure that only trustworthy content is downloaded. Only install software and firmware updates that have been authenticated by the manufacturer.

3 Overview

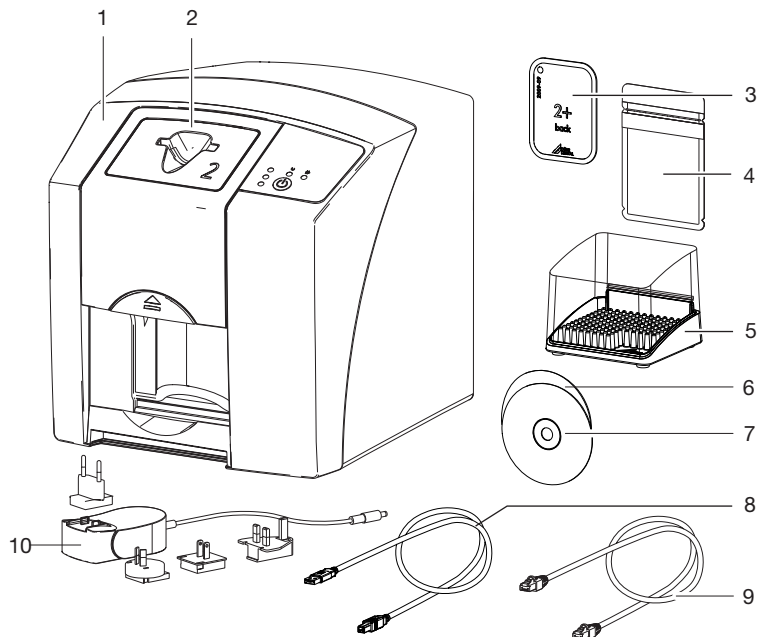

- 1 VistaScan Mini Easy image plate scanner
- 2 Input unit cover
- 3 Plus intraoral image plate
- 4 Light protection cover intraoral
- 5 Storage box
- 6 DBSWIN imaging software DVD
- 7 VistaSoft imaging software DVD
- 8 USB cable
- 9 Network cable
- 10 Power supply unit with country-specific adapter

3.1 Scope of delivery

The following items are included in the scope of delivery (possible variations due to country-specific requirements and/or import regulations):

**VistaScan Mini Easy
image plate scanner** **2143-61**

**VistaScan Mini Easy
image plate scanner** **2143-67**

**VistaScan Mini Easy
image plate scanner** **2143-52**

- VistaScan Mini Easy basic unit
- Power supply unit
- USB cable
- Network cable
- DBSWIN imaging software DVD
- VistaSoft imaging software DVD
- Input unit cover for the image plate – size 0
- Input unit cover for the image plate – size 2
- Plus image plate:
 - Size 0
 - Size 2
- Light protection covers Plus:
 - Size 0
 - Size 2
- Storage box
- Protection cover
- Image Plate Cleaning Wipe
- Installation and operating instructions
- Quick start instructions

3.2 Accessories

The following items are required for operation of the device, depending on the application:

Image plates

- Image Plate Plus, size 0
- Image Plate Plus, size 2

Light protection covers

- Light Protection Cover Plus, size 0
- Light Protection Cover Plus, size 2
- Light Protection Cover Plus, size 0, white
- Light Protection Cover Plus, size 2, white

3.3 Optional items

The following optional items can be used with the unit:

Wall bracket 2141-001-00
Storage box 2141-002-00

Image plate and film holder system
set 2130100015

Image plate and film holder system
conversion set for endo-exposures . 2130100014

Copper dot set, self-adhesive 2130-006-00

Mobile Connect (for using apps
for mobile appliances, e.g. Dürr
Dental Imaging iPad app) 2100-725-12FC

Protection cover 2141-003-01

Commissioning and intraoral constancy tests
Intra / extra digital test body 2121-060-54

3.4 Consumables

The following materials are consumed during operation of the device and must be reordered separately:

Cleaning and disinfection

Image plate cleaning wipes
(10 pcs.) CCB351B1001

FD 350 Classic
disinfection wipes CDF35CA0140

FD 333
rapid surface disinfection CDF333C6150

FD 322
rapid surface disinfection CDF322C6150

FD 366 sensitive rapid surface
disinfection CDF366C6150

Light protection covers

Light Protection Cover Plus size 0
2 x 3 cm (100 pcs.) 2130-080-00

Light Protection Cover Plus size 2
3 x 4 cm (300 pcs.) 2130-082-00

Light Protection Cover Plus size 2
3 x 4 cm (1000 pcs.) 2130-082-55

Light Protection Cover Plus size 0,
white
2 x 3 cm (100 pcs.) 2130-080-50

Light Protection Cover Plus size 2,
white
3 x 4 cm (300 pcs.) 2130-082-50

3.5 Wear parts and replacement parts

Image plates

Plus image plate, size 0
2 x 3 cm (2 pcs.) 2130-040-50

Plus ID image plate, size 0
2 x 3 cm (2 pcs.) 2130-040-60

- Plus image plate, size 2
3 x 4 cm (4 pcs.) 2130-042-50
- Plus image plate, size 2
3 x 4 cm (12 pcs.) 2130-042-55
- Plus ID image plate, size 2
3 x 4 cm (4 pcs.) 2130-042-60

Input unit cover

- Input unit cover for the image plate
– size 0 2143-100-30
- Input unit cover for the image plate
– size 2 2143-100-32



Information about replacement parts is available from the portal for authorised specialist dealers at:
www.duerrdental.net.

4 Technical data

4.1 Image plate scanner

Electrical data for the device		
Voltage	V DC	24
Max. current consumption	A	1.25
Output	W	< 30
Type of protection		IP20
Electrical data – power supply unit		
Voltage	V AC	100 - 240
Frequency	Hz	50/60
Protection class		II
Type of protection		IP20
Output	W	< 40
Max. current consumption	A	0.8
Classification		
Medical product class		I
Laser class (unit)		1
In accordance with IEC 60825-1:2014		
Laser source		
Laser class		3B
In accordance with IEC 60825-1		
Wavelength λ	nm	635
Output	mW	10
Noise level		
Ready to scan	dB(A)	approx. 37
During scanning	dB(A)	approx. 55
General technical data		
Dimensions (W x H x D)	mm	226 x 234 x 243
	in	8.89 x 9.21 x 9.56
Weight	kg	approx. 6.5
	lb	approx. 14.33
Duty cycle S2 (in accordance with VDE 0530-1)	min	25
Duty cycle S6 (in accordance with VDE 0530-1)	%	25
Pixel size (selectable)	μ m	12.5 - 50

General technical data

Max. theoretical resolution	Line pairs/mm (Lp/mm)	approx. 40
-----------------------------	-----------------------	------------

Network connection

LAN technology		Ethernet
Standard		IEEE 802.3u
Data rate	Mbit/s	100
Connector		RJ45
Type of connection		Auto MDI-X
Cable type		≥ CAT5

Serial interfaces

Standard		USB 2.0
Connection (on the unit)		Standard type B

Ambient conditions during operation

Temperature	°C	+10 to +35
	°F	+50 to +95
Relative humidity	%	20 - 80
Air pressure	hPa	750 - 1060
Height above sea level	m	< 2000
	ft	< 6562

Ambient conditions during storage and transport

Temperature	°C	-20 to 60
	°F	-4 to +140
Relative humidity	%	10 - 95
Air pressure	hPa	750 - 1060

Electromagnetic compatibility (EMC)

Interference emission measurements

High-frequency emissions in accordance with CISPR 11		Group 1 Class B
Interference voltage at the power supply connection CISPR 11:2009+A1:2010		Compliant
Electromagnetic interference radiation CISPR 11:2009+A1:2010		Compliant

Electromagnetic compatibility (EMC) Interference immunity measurements on the cover

Immunity to electrostatic discharge

IEC 61000-4-2:2008

± 8 kV contact

± 2 kV, ± 4 kV, ± 8 kV, ± 15 kV air

Compliant

Immunity to high-frequency electromagnetic fields

IEC 61000-4-3:2006+A1:2007+A2:2010

3 V/m

80 MHz–2.7 GHz

80% AM at 1 kHz

Compliant

Immunity to near fields of wireless HF communication devices

IEC 61000-4-3:2006+A1:2007+A2:2010

See immunity to interference table, near fields of wireless HF communication devices

Compliant

Immunity to interference table, near fields of wireless HF communication devices

Radio service	Frequency band MHz	Test level V/m
TETRA 400	380 - 390	27
GMRS 460 FRS 460	430 - 470	28
LTE band 13, 17	704 - 787	9
GSM 800/900 TETRA 800 iDEN 820 CDMA 850 LTE band 5	800 - 960	28
GSM 1800 CDMA 1900 GSM 1900 DECT LTE band 1, 3, 4, 25 UMTS	1700 - 1990	28
Bluetooth WLAN 802.11 b/g/n RFID 2450 LTE band 7	2400 - 2570	28
WLAN 802.11 a/n	5100 - 5800	9

Electromagnetic compatibility (EMC) Interference immunity measurements supply input

Immunity to interference, rapid transient bursts – AC voltage grid

IEC 61000-4-4:2012

± 2 kV

100 kHz repetition frequency

Compliant

**Electromagnetic compatibility (EMC)
Interference immunity measurements supply input**

Immunity to interference, surges
IEC 61000-4-5:2005
± 0.5 kV, ± 1 kV Compliant

Immunity to interference, line-conducted disturbances induced by high-frequency fields – AC voltage grid
IEC 61000-4-6:2013
3 V
0.15 - 80 MHz Compliant
6 V
ISM frequency bands
0.15 - 80 MHz
80 % AM at 1 kHz

Immunity to interference due to voltage dips, short interruptions and voltage variations
IEC 61000-4-11:2004 Compliant

**Electromagnetic compatibility (EMC)
Interference immunity measurements SIP/SOP**

Immunity to interference, discharge of static electricity
IEC 61000-4-2:2008
± 8 kV contact Compliant
± 2kV, ± 4 kV, ± 8 kV, ± 15 kV air

Immunity to interference, rapid transient bursts – I/O, SIP/SOP ports
IEC 61000-4-4:2012 Compliant
± 1 kV
100 kHz repetition frequency

Immunity to interference, line-conducted disturbances induced by high-frequency fields – SIP/SOP ports
IEC 61000-4-6:2013
3 V
0.15 - 80 MHz Compliant
6 V
ISM frequency bands
0.15 - 80 MHz
80 % AM at 1 kHz

4.2 Image plate

Classification

Medical devices class IIa

Ambient conditions during operation

Temperature	°C	18 - 45
	°F	64 - 113
Relative humidity	%	< 80

Ambient conditions during storage and transport

Temperature	°C	< 33
	°F	< 91
Relative humidity	%	< 80

Dimensions of intraoral image plates

Size 0	mm	22 x 35
	in	0.87 x 1.38
Size 2	mm	31 x 41
	in	1.22 x 1.61

4.3 Light protection cover**Classification**

Medical product class	I
-----------------------	---

4.4 Type plate

The type plate is located on the rear of the device.

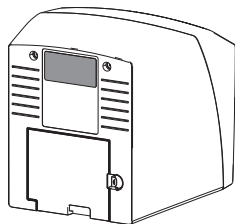

REF Order number

SN Serial number

4.5 Evaluation of conformity

This device has been subjected to conformity acceptance testing in accordance with the current relevant European Union guidelines. This equipment conforms to all relevant requirements.

5 Operation

5.1 Image plate scanner

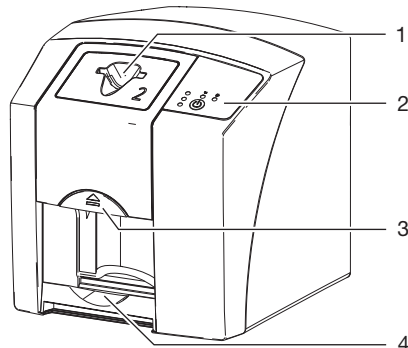

- 1 Intake slot
- 2 Operating elements
- 3 Release key
- 4 Collection tray

The image plate scanner is used to read image data stored on an image plate and to transfer the data to the imaging software (e.g. VistaSoft) on a computer.

The transport mechanism guides the image plate through the device. The image plate is read using a laser inside the scanner unit. The scanned data is converted into a digital image and transferred to the imaging software.





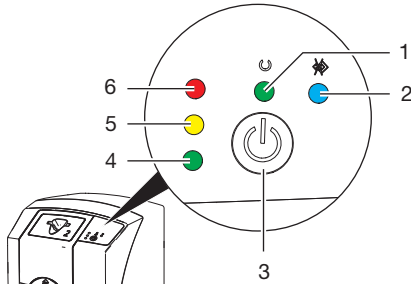







After scanning, the image plate runs through the erasure unit. Image data still held on the image plate is erased with the aid of bright light. The image plate is then ejected for re-use.

Operating elements



- 1 Green operating LED
- 2 Blue communication indicator
- 3 On / off switch
- 4 Green status LED
- 5 Yellow status LED
- 6 Red status LED

The status LEDs display the following status messages:

	Ready for operation
	Not ready for communication
	Device currently switching off
	
	Error
	Cover missing
	Image plate currently being processed
	Image plate currently being processed Light protection cover can be removed and the next image plate can be inserted
	Input unit ready for operation The next image plate can be inserted
	Device starting up from standby mode
	Status LED flashing
	Status LED off

Connections

The connections are located on the rear of the unit, underneath the cover.

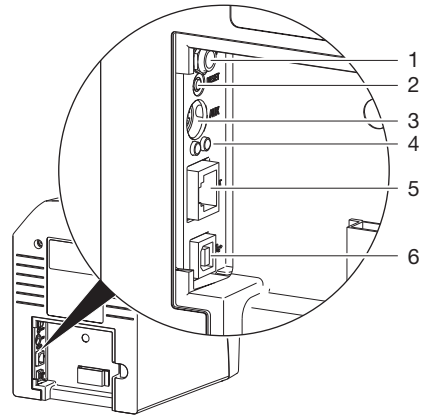

- 1 Connection for power supply unit
- 2 Reset button
- 3 AUX connection for diagnostic units
- 4 Network connection status LEDs
- 5 Network connection
- 6 USB port

5.2 Image plate

The image plate stores X-ray energy, which is re-emitted in the form of light after excitation via the laser. This light is then converted to image information in the image plate scanner.

The image plate has an active side and an inactive side. The image plate must always be exposed on the active side.

When used properly, image plates can be exposed, read and erased several hundred times provided there is no mechanical damage. The image plate must be replaced if there are any signs of damage, e.g. if the protective layer is damaged or there are visible scratches that could interfere with the diagnosis.

Intraoral

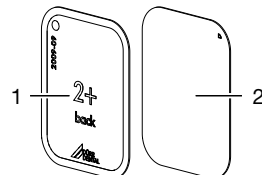

- 1 Inactive side Black, printed with the word "back" and the size and manufacturer's information
- 2 Active side Light blue, with positioning aid 

The positioning aid  is visible on the X-ray image and makes it easier to align the image correctly during diagnosis.

Exposure from the wrong side

A marker is attached to the inactive side of the image plate.

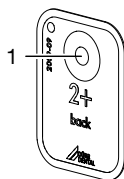

- 1 Marker

If the image plate has been exposed from the wrong side, the marker is visible as a shadow in the X-ray image.

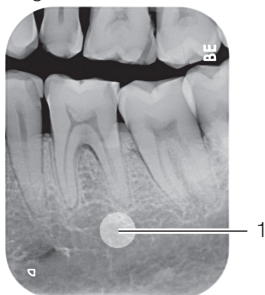

- 1 Marker visible as a shadow

The image can be corrected by mirroring it in the software. If a diagnosis is not possible in the area of the marker then the image will need to be acquired again.

 With the aid of the copper dots set you can retrospectively add a marker to image plates (see "3.3 Optional items").

Clear assignment of image plate to image (Image Plate Plus ID only)

On the Image Plate Plus ID there is also a hexadecimal code on the image plate in addition to the marker. This code can be seen in the X-ray image.

This code allows you to clearly assign the correct image plate to the X-ray image.

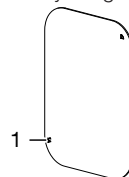

- 1 Hexadecimal code

5.3 Light protection cover

The light protection cover protects the image plate against light.

5.4 Protection cover

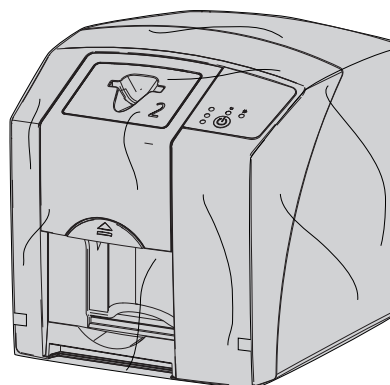

The protective cover protects the device against dust and dirt, for example during extended periods in which it is not in use.

5.5 Storage box

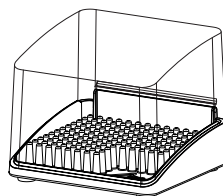



Image plates packaged in light protection covers can be stored in the storage box until they are next used. The storage box protects the image plate and the light protection cover against contamination and dirt.

 Assembly

-  Only qualified specialists or employees trained by Dürr Dental are permitted to install, connect and start using the unit.

6 Requirements

6.1 Installation/setup room

The room chosen for set up must fulfil the following requirements:

- Closed, dry, well-ventilated room
- It should not be a room made for another purpose (e.g. boiler room or wet cell).
- Max. light intensity 1000 Lux, no direct sunlight at the place of installation of the unit
- There should be no large fields of interference (e.g. strong magnetic fields) present that can interfere with the correct operation of the unit.
- Refer to the requirements for environmental conditions in "4 Technical data".

6.2 System requirements

-  The system requirements for the computer systems can be found in the download area at www.duerrdental.com (document no. 9000-618-148).

6.3 Monitor

The monitor must comply with the requirements for digital X-ray with a high light intensity and wide contrast range.

Strong ambient light, sunlight falling directly onto the monitor and reflections can make it harder or even impossible to perform a diagnosis based on the X-ray images.

7 Installation

7.1 Carrying the unit

-  **NOTICE**
Risk of damage to sensitive components in the unit as a result of shocks or vibrations
- › Do not expose the unit to any strong vibrations or shocks.
 - › Do not move the unit during operation.

7.2 Setting up the unit

Portable and mobile HF communication appliances can interfere with the effectiveness of electrical medical devices.

- › Do not stack the unit next to or together with other appliances.
- › If, however, this unit is operated next to other units or stacked with other units, monitor the unit carefully in the configuration selected in order to ensure normal operation.

The unit can be set up as a tabletop unit or mounted on a wall using the wall bracket.

The load-bearing capacity of the table or wall must be suitable for the weight of the unit (see "4 Technical data").

Setting the unit on a table

-  To prevent errors when scanning the image data, install the unit so it is not exposed to vibrations.
- › Place the unit on a firm, horizontal surface.

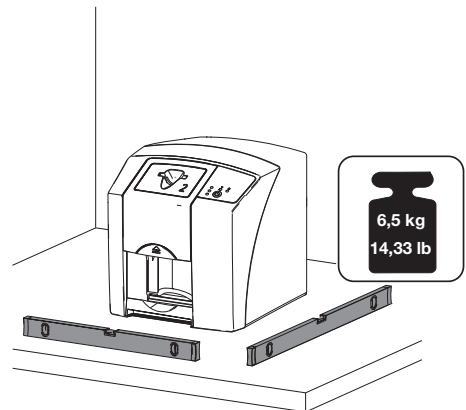

Installing the unit with the wall mounting bracket

The unit can be mounted on a wall with the wall mounting bracket (see "3.3 Optional items").

-  For installation refer to the installation instructions for the wall mounting (order number 9000-618-162)

7.3 Electrical connections

Safety when making electrical connections

- › The device must only be connected to a correctly installed power outlet.
- › Do not place non-fixed multi-socket units on the floor. Follow the requirements in section 16 of IEC 60601-1 (EN 60601-1).
- › Do not operate any other systems using the same multiple socket.
- › Make sure that none of the electrical cables leading to the unit are under any mechanical tension.
- › Before initial start-up check that the mains supply voltage and the voltage stated on the type plate match (see also "4. Technical data").

Connecting the unit to the mains supply

-  The unit has no main power switch. For this reason it is important that the unit is set up in such a way that the plug can be easily accessed and unplugged if required.

Requirements:

- ✓ Properly installed power outlet close to the unit (observe the max. mains cable length)
- ✓ Easily accessible power outlet
- ✓ Mains voltage must match the information shown on the type plate of the power supply unit
- › Attach the matching country-specific adapter to the power supply unit.

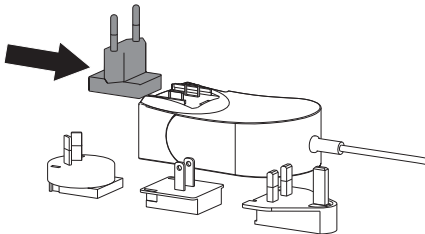

- › Remove the cover from the rear of the device.

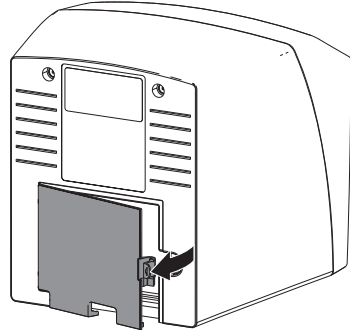

- › Plug in the connecting plug of the power supply unit into the socket connection of the device.
- › Secure the cable with a cable clip.

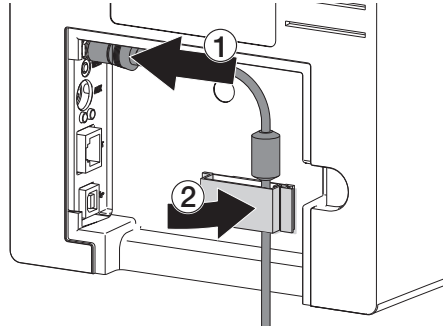

- › Plug the mains plug into the power outlet.
- › Refit the cover.

-  The cover on the rear must be correctly fitted when the device is operated within the patient environment.

7.4 Connecting the unit

The device can be connected either via the USB port or via the network connection. If you are using VistaSoft/VistaConnect, the device can only be operated via the network. The cables are included in the scope of delivery.

-  Do not connect the device via the USB port and via the network connection at the same time.

If the device is connected via the USB port and via the network connection at the same time, the network connection will take priority.

Combining devices safely

Take care when connecting units together or to parts of other systems as there is always an element of risk (e.g. due to leakage currents).

- › Only connect units when there can be no question of danger to operator or to patient.
- › Only connect units when it is safe to do so and when there is no risk of damage or harm to the surroundings.
- › If it is not 100% clear from the unit data sheet that such connections can be safely made or if you are in any doubt, always get a suitably qualified person (e.g. the manufacturer) to verify that the setup is safe.
- The overall safety of the unit and its main performance features are independent of the network.
- Incorrect manual configuration can lead to significant network problems. The expert knowledge of a network administrator is required for configuration.
- If, for example, the following changes are made to the network, new risks can arise that require further analysis.
 - Changes in the IT network configuration
 - Connecting additional elements to the IT network
 - Removing elements from the IT network
 - "Update" of devices that are connected to the IT network
 - "Upgrade" of devices that are connected to the IT network
- The data connection utilises part of the bandwidth of the network. Interactions with other medical devices cannot be completely ruled out. Apply the IEC 80001-1 standard for risk assessment.
- The device is not suitable for direct connection to the public internet.
- › Observe the specifications of IEC 60601-1 (EN 60601-1) when connecting the appliance with other appliances, e.g. a PC system, both in and outside the patient environment.
- › Only connect peripheral units (such as computers, monitors or printers) that conform at least to the requirements set out in IEC 60950-1 (EN 60950-1).
- › The connected computer must conform to EN 55032 (class B) and EN 55024.



A copy of the system manufacturer's declaration in accordance with Article 12 of Directive 93/42/EEC can be found in our download section at www.duerrdental.com (document no. 9000-461-264).

Connecting the unit via the network cable

Purpose of the network connection

The network connection is used to exchange information or control signals between the unit and a software installed on a computer, in order to, e. g.:

- Display parameters
- Select operating modes
- Indicate messages and error situations
- Change unit settings
- Activate test functions
- Transmit data for archiving
- Provide documents concerning the units
- › Remove the cover from the rear of the device.
- › Connect the supplied network cable to the network connection of the device.

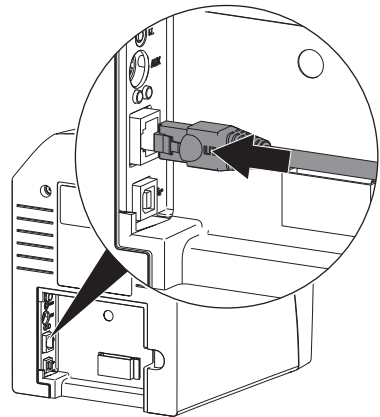

- › Refit the cover.



The cover on the rear must be correctly fitted when the device is operated within the patient environment.

Connecting the unit via the USB port



Only connect the USB cable to the computer when the installation wizard asks you to do so.

- › Remove the cover from the rear of the device.

- › Connect the USB cable to the device.

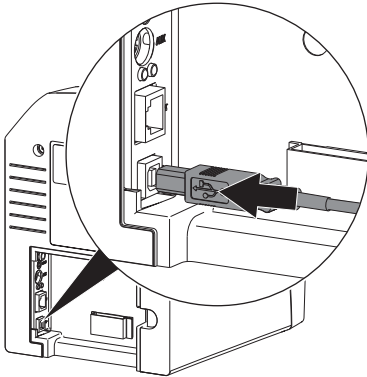

i The cover on the rear must be correctly fitted when the device is operated within the patient environment.

- › Refit the cover.

8 Commissioning



NOTICE

Short circuit due to the build up of condensation

- › Do not switch on the unit until it has warmed up to room temperature and it is dry.

The unit supports the following imaging programs:

- VistaSoft from Dürr Dental
- VistaConnect from Dürr Dental
- DBSWIN from Dürr Dental
- VistaEasy from Dürr Dental
- Third-party software on request



Always use the current version of the imaging program when commissioning the unit. Check the version of the imaging program supplied with the unit against the versions available at www.duerrdental.com.

8.1 Set up the network (only with network connection)

Network configuration

Various options are available for network configuration:

- ✓ Automatic configuration via DHCP.
- ✓ Automatic configuration via Auto-IP for direct connection of unit and computer.
- ✓ Manual configuration.
- › Configure the network settings of the unit using the software or, if applicable, the touch screen.
- › Check the firewall and release the ports, if applicable.

Network protocols and ports

Port	Purpose	Service
45123 UDP, 45124 UDP	Unit recognition and configuration	
2006 TCP	Unit data	
514 ¹⁾ UDP	Event protocol data	Syslog
2005 TCP, 23 TCP	Diagnosis	Telnet, SSH

1) The port can vary depending on the configuration.

 When the unit is first connected to a computer, it applies the language and time settings of the computer.

8.2 Driver installation (USB port only)

 Only connect the USB cable to the computer when the installation wizard asks you to do so.

- > Close all programs.
- > Insert the supplied DBSWIN DVD (version 5.3.1 or higher) into the DVD drive. The start window opens.
- > If the DVD does not start to play automatically, double-click the file *CD_Start.exe*.
- > Select the required language.
- > Open the *Drivers* tab.

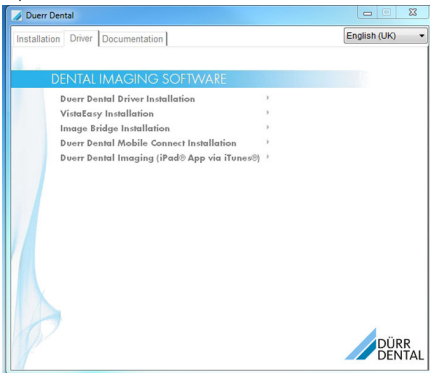

- > Click *Duerr Dental Driver Installation*.

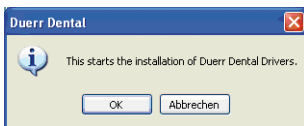

- > Click *OK* to confirm. The *Duerr Dental Driver Setup* installation wizard opens.
- > Follow the instructions of the installation wizard.

8.3 Configuring the unit in VistaSoft

Configuration is performed directly in VistaSoft.

- >  *Select the unit*.

- > Mark the connected unit in the list.

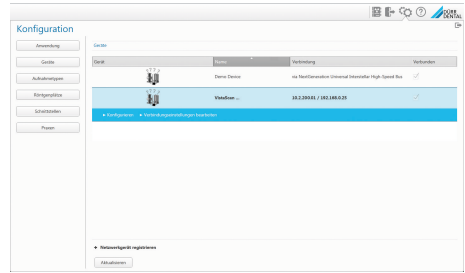

- > Click on *Edit connection settings*.
- > The unit name (designation) can be changed and information queried working under *General*.
- > An IP address can be entered manually and DHCP can be activated / deactivated working under *Connection*.
- > Extended functions e. g. IP address 2 can be set working under *Extended*.

Entering a fixed IP address (recommended)

 To reset the network settings, keep the unit reset key pressed for 15 - 20 seconds while switching on.

- > Working under *Connection*, deactivate DHCP.
- > Enter the IP address, subnet mask and gateway.
- > Navigate back to *Units* via the navigation bar or close Flyout using . The configuration is saved.

Testing the device

You can scan in an X-ray image to check that the unit is properly connected.

- > Open VistaSoft.
- > Create an X-ray station for the connected unit.
- > Log-in the demo patient (patient ID: DEMO0001).
- > Select the image type (e. g. Intraoral).
- > Scan an image plate, see "10.3 Scanning the image data".

8.4 Configuring the appliance in DBSWIN

Configuration is carried out using VistaNetConfig, which is automatically installed during installation of DBSWIN or VistaEasy.

- › Select *Start > All Programs > Dürr Dental > VistaConfig > VistaNetConfig*.

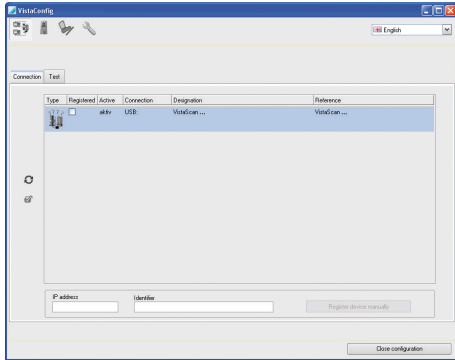

- › Click . The list of connected units is updated.
- › Activate the connected unit in the *Registered* column. You can also register multiple units.

Configuring the device with a USB port

In the *VistaNet device configuration* window you can change the device *Name* and check the configuration.

- › Click on .

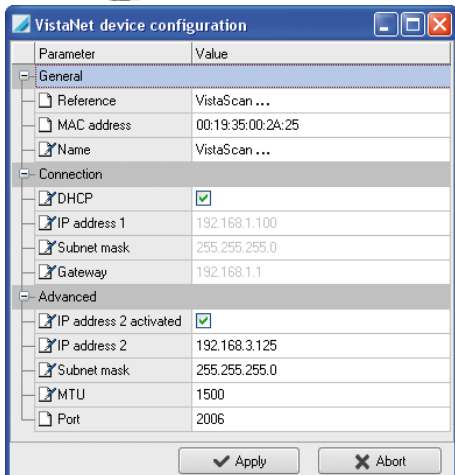

- › If necessary change the *name*.

- › Click *Apply* to save the configuration.

Configuring the device with a network connection

The *VistaNet device configuration* window allows you to change the device name (*name*), manually enter an IP address or call up information.

- › Click .

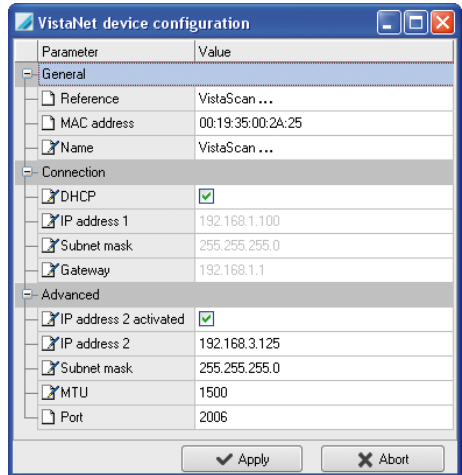

- › If necessary change the *name*.
- › Click *Apply* to save the configuration.

Entering a fixed IP address (recommended)

To reset the network settings, keep the unit reset key pressed for 15 - 20 seconds while switching on.

- › Deactivate *DHCP*.
- › Enter the IP address, subnet mask and gateway.

- › Click on *Apply*.
The configuration is saved.

Testing the device

You can scan in an X-ray image to check that the unit is properly connected.

- › Select the *Test* tab.

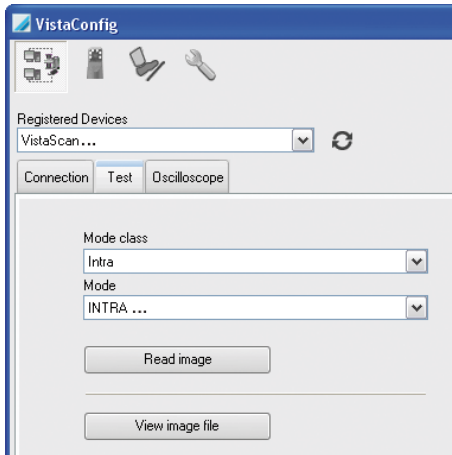

- › Select the unit from the *Registered Units* list.
- › Select the mode class.
- › Select the mode.
- › Click on *Scan Image*.
- › Scan an image plate, see "10.3 Scanning the image data".

EN 8.5 X-ray unit settings

Intraoral X-ray units



If 60 kV can be set on the X-ray unit, this setting is preferred.

The standard exposure values for F-speed film (e. g. Kodak Insight) can be used.

The following table shows the standard values for the exposure time and the dose area product of an image plate for an adult patient.

	DC emitter, 7 mA Tube length 20 cm					
	Without X-ray field limitation		X-ray field limitation 2x3		X-ray field limitation 3x4	
	60 kV	mGycm ²	60 kV	mGycm ²	60 kV	mGycm ²
Incisors	0.08 s	14.6	0.08 s	3.1	0.08 s	6.2
Premolars	0.12 s	21.9	0.12 s	4.6	0.12 s	9.3
Molars	0.17 s	31.1	0.17 s	6.6	0.17 s	13.2
Bite wing	0.18 s	32.9	0.18 s	7.0	0.18 s	14

	DC emitter, 6 mA Tube length 30 cm					
	Without X-ray field limitation		X-ray field limitation 2x3		X-ray field limitation 3x4	
	70 kV	mGycm ²	70 kV	mGycm ²	70 kV	mGycm ²
Incisors	0.13 s	11.8	0.13 s	2.5	0.13 s	5.0
Premolars	0.18 s	16.4	0.18 s	3.4	0.18 s	6.9
Molars	0.25 s	22.8	0.25 s	4.8	0.25 s	9.6
Bite wing	0.27 s	24.6	0.27 s	5.2	0.27 s	10.4

› Check and adjust the specific X-ray unit in accordance with the standard values.

The following table shows the standard values for the exposure time and the dose area product of an image plate for a child patient.

	DC emitter, 7 mA Tube length 20 cm					
	Without X-ray field limitation		X-ray field limitation 2x3		X-ray field limitation 3x4	
	60 kV	mGycm ²	60 kV	mGycm ²	60 kV	mGycm ²
Incisors	0.05 s	9.1	0.05 s	1.9	0.05 s	3.8
Premolars	0.07 s	12.8	0.07 s	2.7	0.07 s	5.4
Molars	0.11 s	20.1	0.11 s	4.2	0.11 s	8.5
Bitewing	0.11 s	20.1	0.11 s	4.2	0.11 s	8.5

	DC emitter, 6 mA Tube length 30 cm					
	Without X-ray field limitation		X-ray field limitation 2x3		X-ray field limitation 3x4	
	70 kV	mGycm ²	70 kV	mGycm ²	70 kV	mGycm ²
Incisors	0.08 s	7.3	0.08 s	1.5	0.08 s	3.1
Premolars	0.11 s	10.0	0.11 s	2.1	0.11 s	4.2
Molars	0.14 s	12.8	0.14 s	2.7	0.14 s	5.4
Bitewing	0.14 s	12.8	0.14 s	2.7	0.14 s	5.4

- › Check and adjust the specific X-ray unit in accordance with the standard values.

8.6 Acceptance tests

The required tests (e.g. acceptance tests) must be carried out in accordance with local rules and regulations.

- › Find out which tests are required.
- › Carry out testing in accordance with local rules and regulations.

Acceptance test

-  The Intra / Extra Digital test body is required for acceptance tests with the image plate and sensor as receivers, and possibly also the corresponding test body holder.
- › Before the unit is started up and used for the first time, the acceptance test of the X-ray system must be carried out in accordance with national regulations.
The consistency tests, which must be carried out at regular intervals by the dental professional, are based on the results of the acceptance test.

Electrical safety checks

- › Carry out the electrical safety check according to the national law (e. g. in accordance with IEC 62353).
- › Document the results.
- › Carry out and document the instruction and handover for the unit.

-  A sample handover report is included in the attachment.

9 Correct use of image plates



CAUTION

Image plates are toxic

Image plates that are not packed in a light protection cover can lead to poisoning when placed in the mouth or swallowed.

- › Only place image plates in the patient's mouth in a light protection cover.
- › Do not swallow the image plate or parts of it.
- › If the image plate or parts of it have been swallowed, consult a specialist doctor immediately and remove the image plate.
- › If the light protection cover has been damaged in the patient's mouth, rinse the mouth thoroughly with lots of water. Do not swallow the water in the process.

- › Image plates are flexible like X-ray film. However, the image plates should not be bent.



- › Do not scratch the image plates. Do not subject the image plates to pressure from hard or pointed objects.

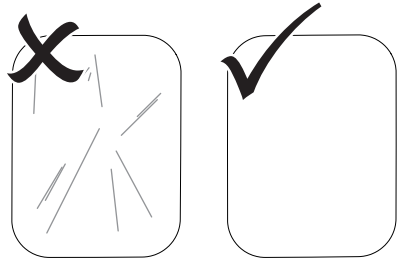

- › Do not soil the image plates.
- › Protect the image plates against sunlight and ultraviolet light. Store image plates in a light protection cover or intraoral/extraoral foil cassette of the correct size.
- › Image plates will be pre-exposed on exposure to natural radiation and stray x-ray radiation. Protect erased and exposed image plates from X-ray interference. If the image plate has been stored for longer than one week, erase the image plate prior to use.
- › Do not store image plates under hot or moist conditions. Observe the correct ambient conditions (see "4 Technical data").
- › When used properly, image plates can be exposed, read and erased several hundred times provided there is no mechanical damage. Replace the image plate if there are any signs of damage (e.g. protective layer is damaged or visible scratches) that could interfere with the diagnosis.
- › Image plates that have a production or packaging defect will be replaced by Dürr Dental in the same quantity. Claims can only be accepted within 7 working days after receipt of the goods.
- › Clean image plates properly (see "11 Cleaning and disinfection").

10 Operation



CAUTION

The image data on the image plate is not permanent.

The image data is altered by light, natural X-ray radiation and scattered X-ray radiation. This will lead to a reduction in diagnostic information and clarity.

- › Read the image data within 30 minutes of exposure.
- › Never handle exposed image plates without the light protection cover.
- › Do not subject an exposed image plate to X-ray radiation before or after the scanning process.

Do not X-ray during the scanning process if the unit is in the same room as the X-ray tube.

10.1 Changing the input unit cover

The device can be used to scan image plates size 2 and size 0. Each size of image plate requires the matching size cover.

The size of the image plate is marked on the cover.

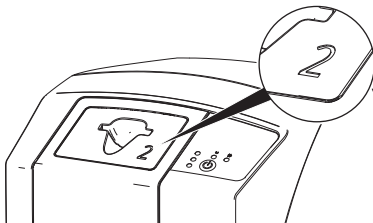

CAUTION

Loss of image information and equipment damage if an incorrect cover is used

- › Always use the correct size of cover for the image plate being used.
- › Before each scanning process, compare the image plate size with the markings on the cover.

- › Check that the green status LED is lit.

- › Press the release button and remove the cover upwards at the same time.

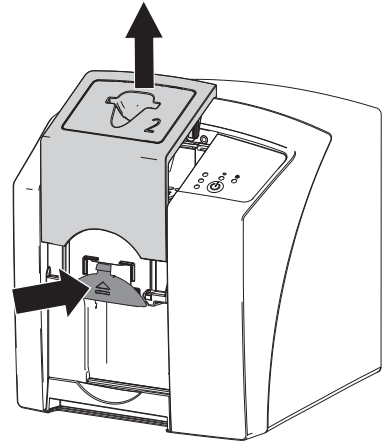

The red status LED flashes.

- › Place the cover into position from above. The green status LED lights up. The input unit is ready.

10.2 X-ray



The procedure is described using a size 2 Image Plate Plus as an example.

Required accessories:

- Image plate
- Light protection cover the same size as the image plate



WARNING

Risk of cross contamination when not using the light protection cover or when using the light protection cover more than once

- › Do not use an image plate without a light protection cover.
- › Do not use the light protection cover more than once (disposable item).



WARNING

Danger due to re-use of products intended for single use

- The disposable item is damaged after use and cannot be reused.
- › Dispose of disposable items after use.

Preparing the X-ray

- ✓ The image plate has been cleaned.
- ✓ The image plate is not damaged.
- ✓ The marker (if present) is stuck in the correct position on the image plate. If the marker peels off, replace the image plate.
- › If using it for the first time or if it has been stored for over a week: erase the image plate (see "10.4 Erasing the image plate").
- › Completely slide the image plate into the light protection cover. The black (inactive) side of the image plate must be visible.

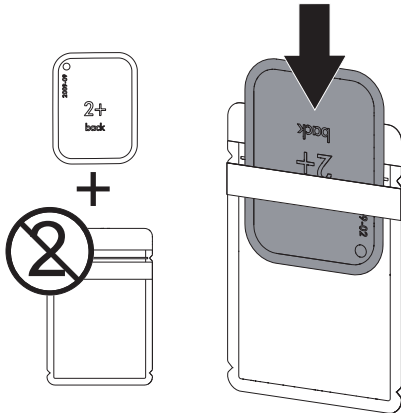

- › Pull off the adhesive strip, fold down the flap and close the light protection cover tightly by pressing together firmly.

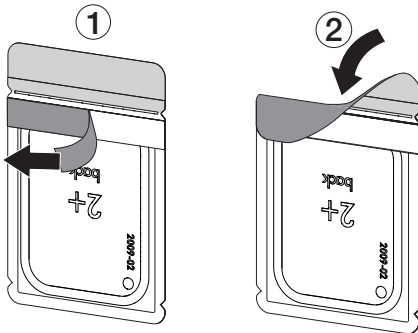

- › The light protection cover must be disinfected using a disinfectant wipe immediately before it is positioned inside the patient's mouth (e.g. with Dürr FD 350). Alternatively, a spray disinfectant (e.g. FD 322, FD 333) can be used on a soft, lint-free cloth.

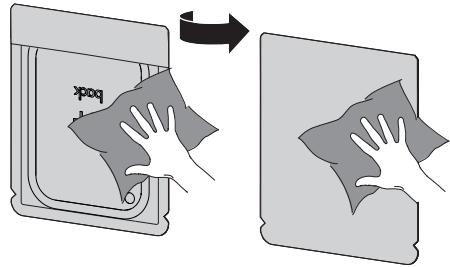

Taking the X-ray image

NOTICE

Damage to the image plate caused by a sharp-edged holding system

- › Only use holding systems that will not damage the light protection cover or the image plates in any way.
- › Do not use holding systems with sharp edges.

-  Wear protective gloves.

- › Place the image plate in the light protection cover into the patient's mouth. When doing this, make sure that the active side of the image plate points towards the X-ray tube.

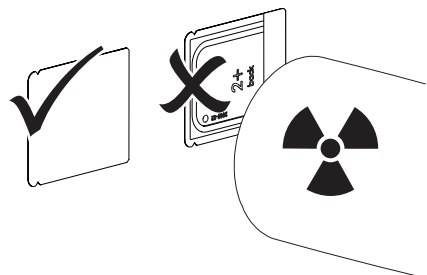

- › Set the exposure time and setting values on the X-ray unit (see "8.5 X-ray unit settings").
- › Record an X-ray image. The image data must be scanned within 30 minutes.

Preparing for scanning



CAUTION

Light erases the image data on the image plate

- › Never handle exposed image plates without the light protection cover.



Wear protective gloves.

- › Remove the image plate with the light protection cover from the patient's mouth.



WARNING

Contamination of the unit

- › Clean and disinfect the light protection cover before removing the image plate.

- › In the event of heavy soiling, e.g. from blood, dry clean the light protection cover and protective gloves, e.g. wipe with a clean cellulose cloth.
- › Disinfect the light protection cover and protective gloves with a disinfection wipe (e.g. FD 350). Alternatively, a spray disinfectant (e.g. FD 322, FD 333) can be used on a soft, lint-free cloth.

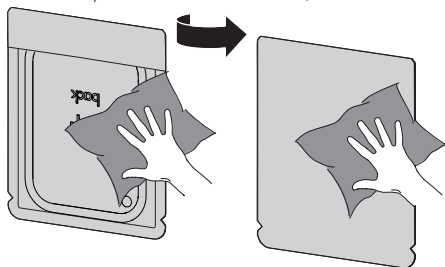

- › Allow the light protection cover to fully dry.
- › Pull off the protective gloves, disinfect and clean the hands.



NOTICE

Powder from the protective gloves on the image plate can damage the unit during scanning

- › Completely clean all traces of the protective glove powder from your hands before handling the image plate.

- › Tear off the light protection cover.

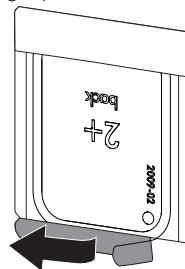

10.3 Scanning the image data

Starting the image plate scanner and software



The reading-out process is described using the VistaSoft imaging software. For further information on using the imaging software, refer to the relevant manual.

- › Press the on / off switch  to switch on the device.
- › Switch on the computer and monitor.
- › Start VistaSoft.
- › Select the patient.
- › Select the corresponding image type in the menu bar.
- › Select the device.
- › Set acquisition mode.
Recording starts directly.

Result:

The status LED illuminates green.

Scanning the image plate

i To avoid the mix up of X-ray images, only scan the X-ray images from the selected patient.

- › Place the light protection cover with the image plate centrally and straight onto the input unit. The opened side of the light protection cover faces down, the inactive side of the image plate faces the operator.

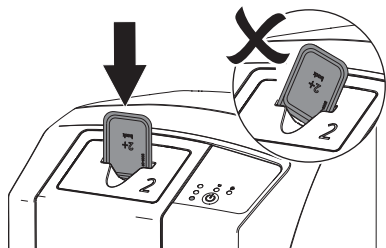

- › Slide the image plate out of its light protection cover downwards into the device until the image plate is automatically drawn in.

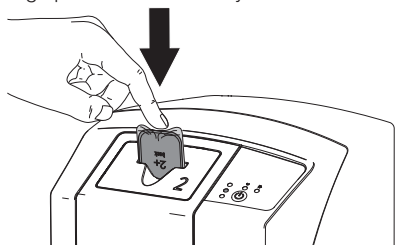

The light protection cover is held at the intake slot and is not drawn into the device. The yellow status LED lights up. The image data is automatically transmitted to the imaging software. The progress of the scanning process is displayed in the preview window on the monitor.

After it has been scanned, the image plate is erased and drops into the collection tray.

- › While the yellow status LED is lit up: Do not remove the light protection cover, and do not insert a new image plate.
- › When the green and yellow status LEDs light up: Remove the empty light protection cover.
- › When the green status LED lights up: Save the X-ray image.

- › Remove the image plate and prepare it for taking a new X-ray.

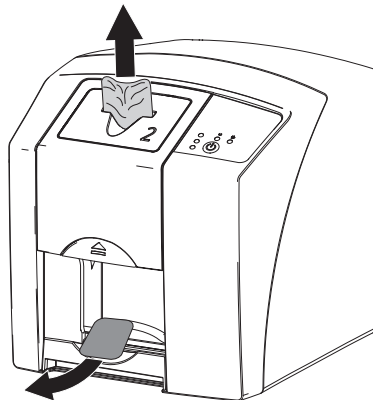

10.4 Erasing the image plate

The image data is automatically erased after scanning.

The special **ERASE** mode only activates the erasure unit of the image plate scanner. No image data is read.

The image plate needs to be erased using the special mode in the following cases:

- The first time the image plate is used, or if it is stored for longer than a week.
- Due to an error, the image data on the image plate has not been erased (software error message).
- › Select the special **ERASE** mode in the software.
- › Insert the image plate (see "Scanning the image plate").

10.5 Switch off the unit.

- › Press the on/off switch  for 3 seconds. While the unit is shutting down the operating and communication LEDs flash. As soon as the unit has shut down it switches off completely. The LEDs go out.

Use of a protective cover

The protective cover protects the device against dirt and dust during extended periods in which it is not used.



WARNING

Danger of suffocation

- › Store the protective cover out of the reach of children.
- › Pull the protective cover over the device so that it is completely covered. Make sure that the markings are at the front.

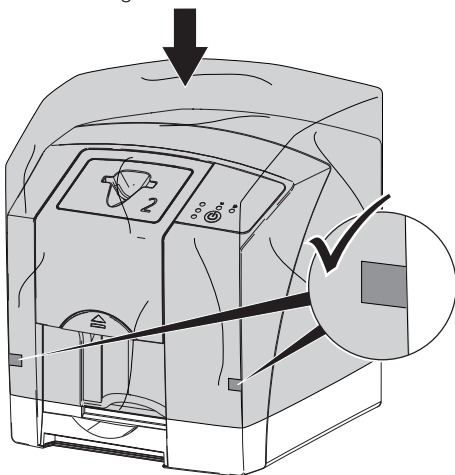

- › Store the protective cover in a safe place when it is not in use.

11 Cleaning and disinfection

When cleaning and disinfecting the unit and its accessories, observe country-specific directives, standards and specifications for medical products as well as the specific specifications for dental practices and clinics.



NOTICE

The use of unsuitable agents and methods can damage the unit and accessories.

- Do not use any products based on phenolic compounds, halogen-releasing compounds, strong organic acids or oxygen-releasing compounds, as they may damage the materials.
- › Dürr Dental recommends using disinfectants from the Dürr Dental product range. Only the products specified in these instructions have been subjected to material compatibility testing by Dürr Dental.
- › Read the operating instructions for the disinfectants.



Wear protective gloves.

11.1 Image plate scanner

Unit surfaces

The unit surface must be cleaned and disinfected of any contamination or visible soiling. Dürr Dental recommends using the disinfectants FD 322, FD 333, FD 350 and FD 366 sensitive.



NOTICE

Liquid can cause damage to the unit.

- › Do not spray the unit with cleaning and disinfectant agents.
- › Make sure that liquid does not get inside the unit.
- › Remove any soiling with a soft, lint-free cloth that has been dampened with cold tap water.
- › Disinfect the surfaces using a disinfection wipe. Alternatively, use disinfectant on a soft, lint-free cloth.

Input unit

The input unit must be cleaned and disinfected if there are indications of contamination or visible dirt.

Use the following cleaning and disinfecting immersion disinfectants:

- ✓ ID 213 Instrument disinfection
- ✓ ID 212
- ✓ ID 212 forte



NOTICE

Heat can damage plastic parts.

- › Do not use a thermal disinfectant or steam steriliser on any parts of the device.

- › Switch off the device by pressing the on/off switch  for 3 seconds.
- › Wait until the operating and communication LEDs go out and the device is completely switched off.
- › Press the release button and remove the cover upwards at the same time.

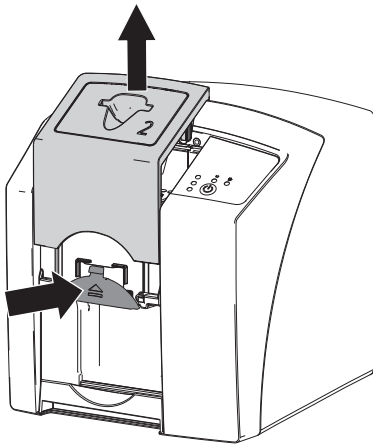

- › Clean the cover and inside parts with a moist, soft, lint-free cloth.

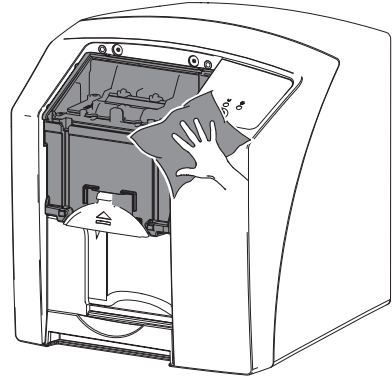

- › Disinfect the cover and inside parts with a disinfection wipe. Alternatively, use a spray disinfectant on a soft, lint-free wipe. Comply with the operating instructions for the disinfectant when doing this. The cover can also be disinfected in an immersion disinfection system.
- › Remount the cover.

11.2 Light protection cover

The surface of the unit must be cleaned and disinfected if it is contaminated or visibly soiled.

- › Disinfect the light protection cover using a disinfectant before and after placement. Dürr Dental recommends FD 333 forte wipes (virucidal), FD 350 (limited virucidal activity) and FD 322 premium wipes (limited virucidal activity).
- › Allow the light protection cover to completely dry before using it.

11.3 Image plate

Cleaning and disinfection wipes are unsuitable for cleaning image plates and may cause damage to them.

Only use a cleaning agent that is compatible with the materials:

Dürr Dental recommends the image plate cleaning wipe (see "3.4 Consumables"). Only this

product has been subjected to material compatibility testing by Dürr Dental.

**NOTICE****Heat or humidity will damage the image plate.**

- › Do not steam sterilise the image plate.
 - › Do not immersion-disinfect the image plate.
 - › Only use cleaning agents that are compatible with the materials.
- › Soiling on both sides of the image plate should be cleaned off with a soft, lint-free wipe prior to every use.
- › Remove resistant or dried on dirt with the image plate cleaning wipe. When doing this, observe the instructions for use for the cleaning wipe.
- › Allow the image plate to completely dry before using it.

11.4 Protection cover

Clean the surface of the protective cover if it is obviously dirty.

- › Clean the protective cover with a soft, lint-free cloth that has been moistened with cold tap water.
- › Only fit the protective cover to a unit that has been cleaned and disinfected.

11.5 Storage box with image plate storage tray

Clean and disinfect the surface of the storage box and the internal image plate storage tray in the event of contamination or visible soiling.

Dürr Dental recommends the following disinfectant for the storage box:

FD 366 sensitive

Dürr Dental recommends the following disinfectants for the image plate storage tray:

FD 350 and FD 366 sensitive

- › Clean the surface of the storage box and the image plate storage tray with a soft, lint-free cloth that has been dampened with cold tap water.
- › Disinfect the storage box using a disinfection wipe. Alternatively, use disinfectant on a soft, lint-free cloth.

- › Disinfect the image plate storage tray using a disinfection wipe. Alternatively, the image plate storage tray can also be treated in a thermal disinfectant or steam steriliser. Do not exceed a temperature of 134°C when doing this.

12 Maintenance

12.1 Recommended maintenance schedule



Only trained specialists or personnel trained by Dürr Dental may service the device.



Prior to working on the unit or in case of danger, disconnect it from the mains.

The recommended maintenance intervals are based on using the device for 15 intraoral images per day on 220 working days per year.

Maintenance interval	Maintenance work
Annually	› Visually inspect the device.
	› Check the image plates for signs of scratches and change if necessary.
	› Check the belt drives, transport belts and springs, and replace if necessary.
	› Remove dust and dirt from accessible parts.
	› Carry out a system check.
Every 3 years	› Replace the light protective cover.
	› Change the roller fixtures.
	› Change the drive belt.

? Troubleshooting

13 Tips for operators and service technicians





Any repairs exceeding routine maintenance may only be carried out by qualified personnel or our service.



Prior to working on the unit or in case of danger, disconnect it from the mains.

13.1 Poor X-ray image

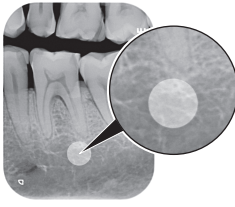
Error	Possible cause	Remedy
X-ray image does not appear on the monitor after scanning	Image plate not fed in straight and inactive side scanned	› Scan the image plate again immediately, making sure you feed it in correctly in the process.
	Image data on the image plate has been erased, e.g. by ambient light	› Always scan the image data of the image plate as quickly as possible.
	Fault on the unit	› Inform a Service Technician.
	No image data on image plate, image plate not exposed	› Expose the image plate.
	X-ray unit is faulty	› Inform a Service Technician.
	Incorrect cover, light protection cover was also drawn into the unit	› Use the correct cover for the size of image plate being used.
X-ray image too dark	X-ray dose too high	› Check X-ray parameters.
	Incorrect brightness/contrast settings in the software	› Adjust the brightness of the X-ray image in the software.
X-ray image too bright	Exposed image plate has been exposed to ambient light	› Always scan the image data of the image plate as quickly as possible.
	X-ray dose too low	› Check X-ray parameters.
	Incorrect brightness/contrast settings in the software	› Adjust the brightness of the X-ray image in the software.
X-ray image only shadowy	The X-ray dose on the image plate was insufficient	› Increase X-ray dose.
	Amplification (HV value) is set too low in the software	› Increase amplification (HV value).
	Unsuitable scanning mode selected	› Select a suitable scanning mode.
	The setting for the threshold value is too high	› Reduce the threshold value.

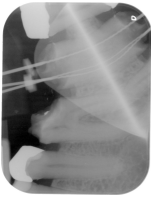
Error	Possible cause	Remedy
<p>Top or bottom bulge in the X-ray image</p> 	<p>Image plate fed in off-centre and at an angle</p>	<ul style="list-style-type: none"> ➤ Insert the image plate centrally and straight.
<p>X-ray image is mirror-inverted</p>	<p>Image plate exposed on the wrong side.</p>	<ul style="list-style-type: none"> ➤ Insert the image plate correctly in the light protection cover. ➤ Position the image plate correctly.
<p>Round shadow on the X-ray image</p> 	<p>Plus ID image plate (with marker) exposed on the wrong side</p>	<ul style="list-style-type: none"> ➤ When taking an X-ray, make sure that the active side faces towards the X-ray tube.
<p>Ghosting or double exposure on X-ray image</p> 	<p>Image plate exposed twice</p> <p>Image plate not sufficiently erased</p>	<ul style="list-style-type: none"> ➤ Only expose the image plate once. ➤ Check the erasure unit is working correctly. ➤ Inform a service technician if the problem persists.
<p>X-ray image mirrored in one corner</p> 	<p>Image plate bent during X-ray exposure</p>	<ul style="list-style-type: none"> ➤ Do not bend the image plate.

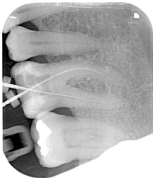
Error	Possible cause	Remedy
Shadow on the X-ray image 	Image plate removed from the light protection cover before scanning	<ul style="list-style-type: none"> › Do not handle image plates without a light protection cover. › Store the image plate in a light protection cover.
X-ray image cut off, part missing 	The metal part of the X-ray tube is in front of the X-ray beam Faulty edge masking in imaging software	<ul style="list-style-type: none"> › When taking an X-ray, make sure there are no metal parts between the X-ray tube and the patient. › Check X-ray tube. › Deactivate edge masking.
Software unable to combine the data to make a complete image	The X-ray dose on the image plate was insufficient Amplification (HV value) is set too low in the software Unsuitable scanning mode selected The setting for the threshold value is too high	<ul style="list-style-type: none"> › Increase X-ray dose. › Increase amplification (HV value). › Select a suitable scanning mode. › Reduce the threshold value.
X-ray image has strips on image	Image plate has been pre-exposed, e.g. by natural radiation or stray X-ray radiation Parts of image plate exposed to light during handling Image plate dirty or scratched	<ul style="list-style-type: none"> › If the image plate has been stored for longer than one week, erase the image plate prior to use. › Do not expose used image plates to bright light. › Scan image data within half an hour after the exposure. › Clean the image plate. › Replace scratched image plates.
Light strips in the scanning window	Too much incident ambient light during the scanning process	<ul style="list-style-type: none"> › Darken the room. › Turn the unit so that the light does not fall directly onto the input unit.

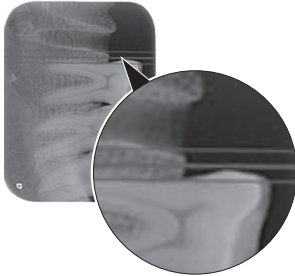
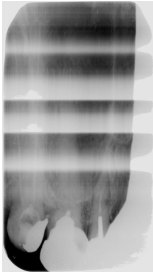
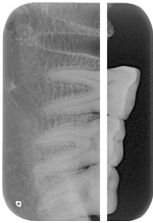
Error	Possible cause	Remedy
<p>Horizontal, grey lines on the X-ray image, extending beyond the left and right image edge</p> 	Transport slipping	› Clean the transport mechanism, replace the transport belts if necessary.
<p>X-ray image is stretched lengthwise with bright, horizontal stripes</p> 	Incorrect light protection cover or image plate used	› Only use original accessories.
<p>X-ray image split vertically into two halves</p> 	Dirt in the laser slit (e.g. hair, dust)	› Clean the laser slit.
<p>X-ray image with small bright spots or clouding</p>	Micro scratches on the image plate	› Replace the image plate.

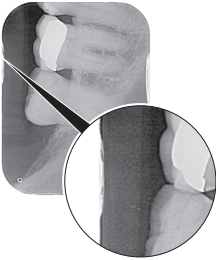
Error	Possible cause	Remedy
Lamination of the image plate becoming detached at the edge 	Incorrect retainer system used	<ul style="list-style-type: none"> › Only use original image plates and film retainer systems.
	Image plate handled incorrectly.	<ul style="list-style-type: none"> › Use the image plate correctly. › Observe the operating instructions for the image plates and film retainer systems.

13.2 Software error

Error	Possible cause	Remedy
"Too much ambient light"	Unit exposed to too much light	<ul style="list-style-type: none"> › Darken the room. › Turn the unit so that no light can fall directly into the entry slot.
"Incorrect power supply unit"	Incorrect power supply unit connected	<ul style="list-style-type: none"> › Use the supplied power supply unit.
"Overtemperature"	Laser or erasure unit too hot	<ul style="list-style-type: none"> › Switch off the unit and allow it to cool.
"Erasure unit fault"	LED defective	<ul style="list-style-type: none"> › Inform a Service Technician.
Imaging software does not recognise the unit	Unit not switched on	<ul style="list-style-type: none"> › Switch on the unit.
	Connecting cable between device and computer not correctly connected	<ul style="list-style-type: none"> › Check the connecting cable.
	Computer does not detect any connection to the unit.	<ul style="list-style-type: none"> › Check the connecting cable. › Check the network settings (IP address and subnet mask).
	Hardware fault	<ul style="list-style-type: none"> › Inform a Service Technician.
	The IP address of the device is being used by another unit	<ul style="list-style-type: none"> › Check the network settings (IP address and subnet mask) and assign a unique IP address to every device. › Inform a service technician if the problem persists.

Error	Possible cause	Remedy
The unit does not appear in the options list in VistaConfig	Unit is connected behind a router	<ul style="list-style-type: none"> › Configure the IP address without an intermediate router on the unit. › Reconnect the router. › Manually enter the IP address in VistaConfig and register the unit.
	The IP address of the device is being used by another unit	<ul style="list-style-type: none"> › Check the network settings (IP address and subnet mask) and assign a unique IP address to every device. › Inform a service technician if the problem persists.
The unit appears in the VistaConfig options list but connection is not possible	Subnet masks of the computer and the unit do not match	<ul style="list-style-type: none"> › Check subnet masks, adjust if necessary.
Error message "E2490"	The connection to the unit was interrupted while the software was still attempting to communicate with the unit	<ul style="list-style-type: none"> › Restore the connection to the unit. › Repeat the process.
Error during data transmission between unit and computer. Error message "CRC error timeout"	Connecting cable used is incorrect or too long	<ul style="list-style-type: none"> › Only use original cables.

13.3 Fault on the unit

Error	Possible cause	Remedy
Unit does not switch on	No mains voltage	<ul style="list-style-type: none"> › Check the mains cable and plug connection and replace if necessary. › Check the power supply unit. › If the green status LED does not light up, replace the power supply unit. › Check the mains fuse in the building.
	On / off switch is defective	<ul style="list-style-type: none"> › Inform a Service Technician.
	Unit switches back off after a short time	Mains cable or power supply unit plug not inserted correctly
Hardware fault		<ul style="list-style-type: none"> › Inform a Service Technician.
Mains supply voltage too low		<ul style="list-style-type: none"> › Check the mains voltage.
Unit is on but none of the indicator LEDs are lit up (status, error or operating LEDs)	Display defective	<ul style="list-style-type: none"> › Inform a Service Technician.

Error	Possible cause	Remedy
Loud operating noises after switching on lasting more than 30 seconds	Radiation deflector defective	› Inform a Service Technician.
Unit not responding	The unit has not yet completed the startup procedure	› After switching on, wait 20 - 30 seconds until the startup procedure has finished.
	Unit is blocked by the firewall	› Enable the ports for the unit in the firewall settings.
Image plate does not fit into the intake slot	Incorrect cover used	› Use the correct cover for the size of image plate being used.
Light protection cover slips into intake slot together with image plate	Incorrect cover (too big) used	› Use the correct cover for the size of image plate being used.
Red status LED flashes	Cover or light protection is missing or not correctly positioned	› Correctly attach the cover and light protection.
Blue communication indicator flashing	No connection between unit and computer	› Check the cables and cable connections. › Enable the unit via the software. › Enable or install the USB drivers.
	Unit data memory is full.	› Check the software settings to make sure the system is ready and able to receive images. The image data is automatically transmitted from the unit to the imaging software.
Network connection has been disconnected	Connecting cable between device and computer not correctly connected	› Check the connecting cable.
	The IP address of the device is being used by another unit	› Check the network settings (IP address and subnet mask) and assign a unique IP address to every device. › Inform a service technician if the problem persists.

14 Scanning times

The scanning time corresponds to the time taken for complete scanning of image data and depends on image plate format and pixel size.

The time to image will depend largely on the computer system used and its work load. Times stated are approximate.

Theoretical resolution (LP/mm)	40	25	20	10
Pixel size (µm)	12.5	20	25	50
Intra Size 0 (2 x 3)	26 s	16 s	13 s	6 s
Intra Size 2 (3 x 4)	32 s	20 s	16 s	8 s

15 File sizes (uncompressed)

The actual file size will depend on the image plate format and the pixel size. File sizes stated are approximate and have been rounded upwards.

Suitable compression methods can considerably reduce the file size without loss of data.

Theoretical resolution (LP/mm)	40	25	20	10
Pixel size (µm)	12.5	20	25	50
Intra Size 0 (2 x 3)	10.4 MB	4.6 MB	2.6 MB	0.65 MB
Intra Size 2 (3 x 4)	17 MB	6.4 MB	4.3 MB	1.1 MB

16 Handover record

This document confirms that a qualified handover of the medical device has taken place and that appropriate instructions have been provided for it. This must be carried out by a qualified adviser for the medical device, who will instruct you in the proper handling and operation of the medical device.

Product name	Order number (REF)	Serial number (SN)

- Visual inspection of the packaging for any damage
- Unpacking the medical device and checking for damage
- Confirmation of the completeness of the delivery
- Instruction in the proper handling and operation of the medical device based on the operating instructions

Notes:

Name of person receiving instruction: **Signature:**

Name and address of the qualified adviser for the medical device:

Date of handover: **Signature of the qualified adviser for the medical device:**

--	--



Hersteller/Manufacturer:

DÜRR DENTAL SE
Höfigheimer Str. 17
74321 Bietigheim-Bissingen
Germany
Fon: +49 7142 705-0
www.duerrdental.com
info@duerrdental.com

