



C17S C17 C22

Guida Rapida Utente
User Quickstart
Démarrage Rapide Utilisateur
Schnellstart Benutzer
Arranque Rápido Usuario
Użytkownika Szybki Rozruch
Kullaniicii Hiizlii Başlatma
Hurtigstart For Bruker Rychlé
Spuštění Pro Uživatele
Vlugge Start
Οδηγισ Εναρξης Λειτουργιασ Χρηστη
Инструкции Для Быстрого Запуска
Arranque Rápido
Användaren snabb start
Käyttäjän pikaopas
مدخستس ملل عي رس ل ا ل ي ل دل ا



C17S C17 C22

cod. 97050692



CE 0051

ITALIANO (Lingua originale)

ENGLISH (translation from the original in Italian)

FRANÇAIS (traduction de l'original en italien)

DEUTSCH (Übersetzung aus dem Original in Italienisch)

ESPAÑOL (traducción del original en italiano)

POLSKA (tłumaczenie z oryginału w języku włoskim)

TÜRKÇE (İtalyan orijinalinden çeviri)

BOKMÅL (oversettelse fra originalen på italiensk)

CEŠTINA (překlad z originálu v italštině)

NEDERLANDSE (vertaling uit het Italiaans)

ΕΛΛΗΝΙΚΑ (αση από το πρωτότυπο στα ιταλικά)

РУССКИЙ (Перевод с оригинала в итальянском)

PORTUGUÊS (tradução do original em italiano)

SVENSKA (översättning från originalspråket italienska)

SUOMI (käännös alkuperäisestä italialaisesta tekstistä)

ةيلاطيإلا ةغللاب يلصلألا صنللا نم ةمجرتلا) ةيبرعلا

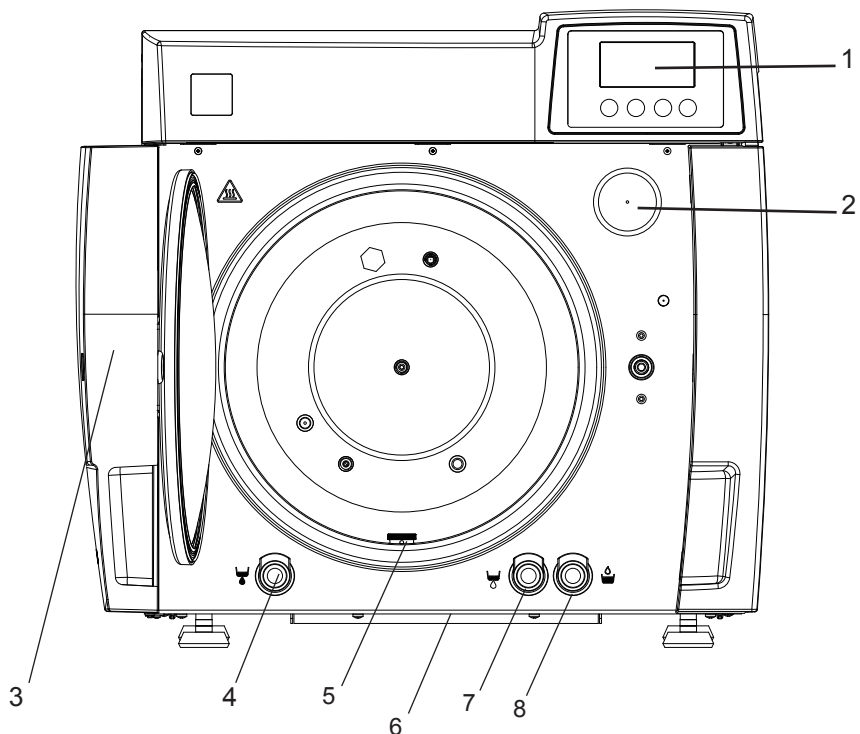
IT

Rif.	Descrizione Apparecchio
1	Pannello comandi e display LCD
2	Filtro batteriologico
3	Portello
4	Innesto rapido di scarico acqua usata
5	Filtro scarico acqua
6	Filtro antipolvere
7	Innesto rapido di scarico serbatoio acqua distillata (SOLO SERVICE)
8	Raccordo rapido rabbocco acqua distillata

EN

Ref.	Device description
1	Control panel and LCD display (TOUCH SCREEN DISPLAY)
2	Bacteriological filter
3	Door
4	Used water drain quick-coupling
5	Water drain filter
6	Dust filter
7	Distilled water tank drain quick-coupling (SERVICE only)
8	Distilled water top-up quick-coupling

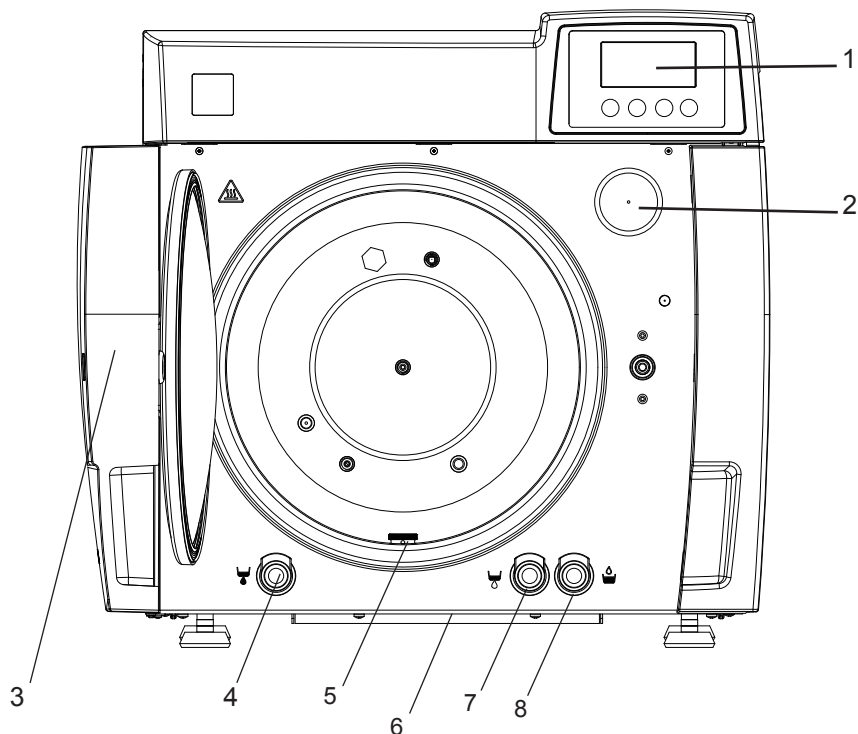

FR

Réf.	Description appareil
1	Panneau de commande et afficheur LCD (ÉCRAN TACTILE)
2	Filtre bactériologique
3	Trappe
4	Raccord rapide de vidange eau usée
5	Filtre de vidange eau
6	Filtre anti-poussière
7	Raccord rapide de vidange du réservoir d'eau distillée (seulement SERVICE)
8	Raccord rapide de remplissage en eau distillée

DE

Ref.	Beschreibung des Geräts
1	Bedienfeld und Display mit LCD-Technologie (TOUCHSCREEN-DISPLAY)
2	Bakteriologischer Filter
3	Türklappe
4	Schnellfitting für Ablass des verbrauchten Wassers
5	Wasserablass-Filter
6	Staubfilter
7	Schnellfitting für Ablass des Behälters für destilliertes Wasser (NUR SERVICE)
8	Schnellanschluss für die Versorgung mit destilliertem Wasser

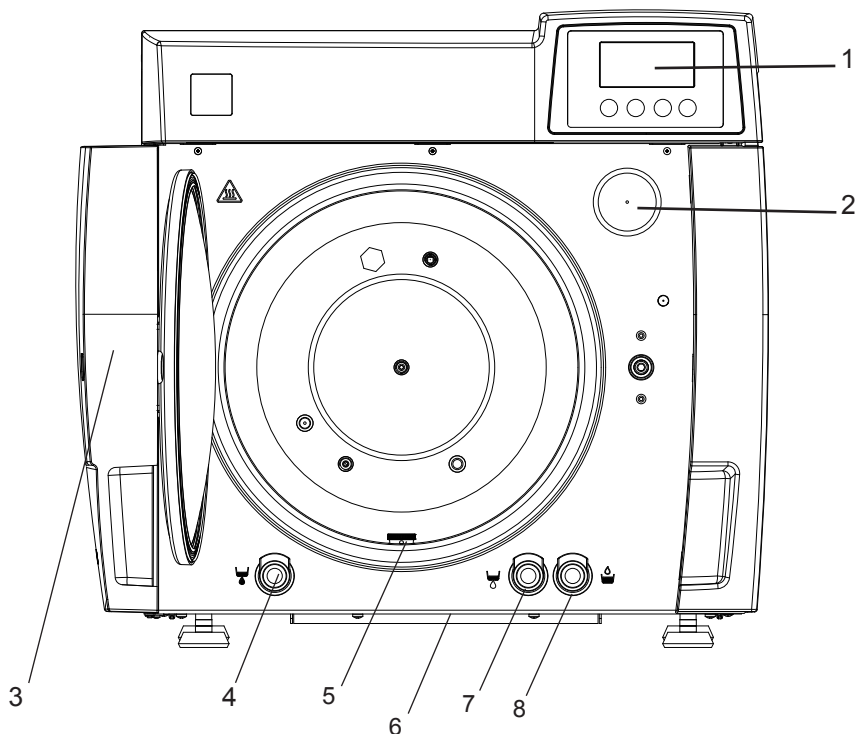
ES

Ref.	Descripción Aparato
1	Panel de mandos y pantalla LCD (DISPLAY PANTALLA TÁCTIL)
2	Filtro bacteriológico
3	Puerta
4	Empalme rápido de desagüe agua utilizada
5	Filtro desagüe
6	Filtro antipolvo
7	Empalme rápido de desagüe del depósito de agua destilada (sólo SERVICE)
8	Empalme rápido llenado agua destilada

PL

Odn.	Opis urządzenia
1	Panel sterowniczy i wyświetlacz LCD (EKRAN DOTYKOWY)
2	Filtr bakteriologiczny
3	Drzwiczki
4	Szybkozłącze opróżniania zużytej wody
5	Filtr spustowy do wody
6	Filtr przeciwpyłowy
7	Szybkozłącze opróżniania zbiornika z destylowaną wodą (TYLKO SERWIS)
8	Szybko-złączka napełniania wody destylowanej

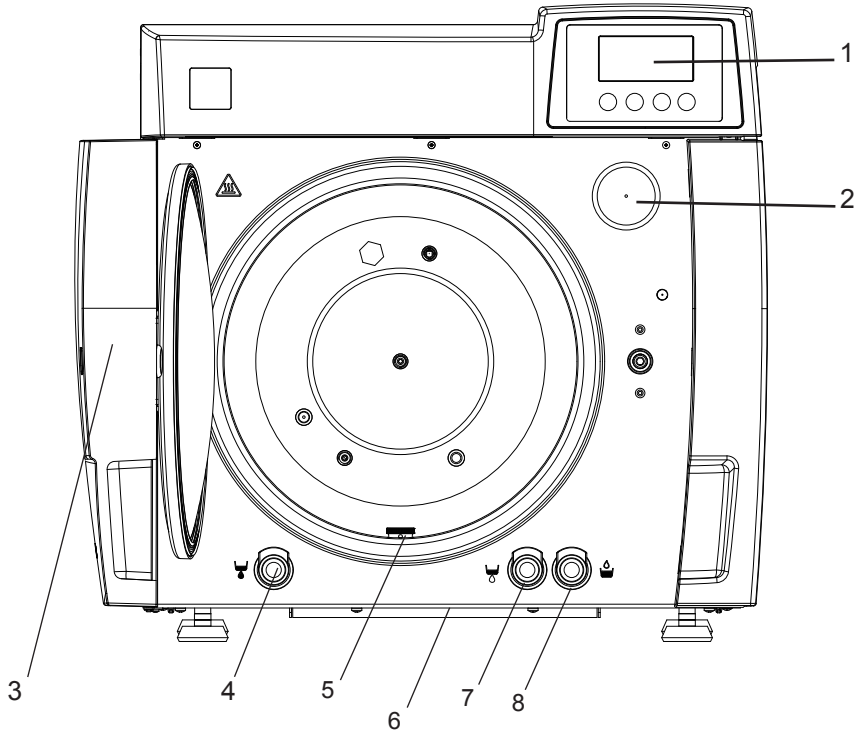

TR

Bkz.	Cihazın Tanımlanması
1	Kontrol paneli ve LCD ekran (DOKUNMATİK EKРАН)
2	Bakteri filtresi
3	Kapak
4	Kullanılmış su tahliyesini hızlı takma sistemi
5	Su tahliye filtresi
6	Toz filtresi
7	Damıtık su deposu tahliyesini hızlı takma sistemi (SADECE SERVIS)
8	Damıtık su hızlı doldurma bağlantısı

NO

Ref.	Beskrivelse Apparat
1	Kommandopanel og LCD display (TOUCH SCREEN DISPLAY)
2	Bakteriologisk filter
3	Luke
4	Hurtigtilkobling for utløpsvann
5	Filter utløpsvann
6	Støvfilter
7	Hurtigtilkobling for tank med destillert vann (KUN SERVICE)
8	Hurtig oppsamling for etterfylling av destillert vann

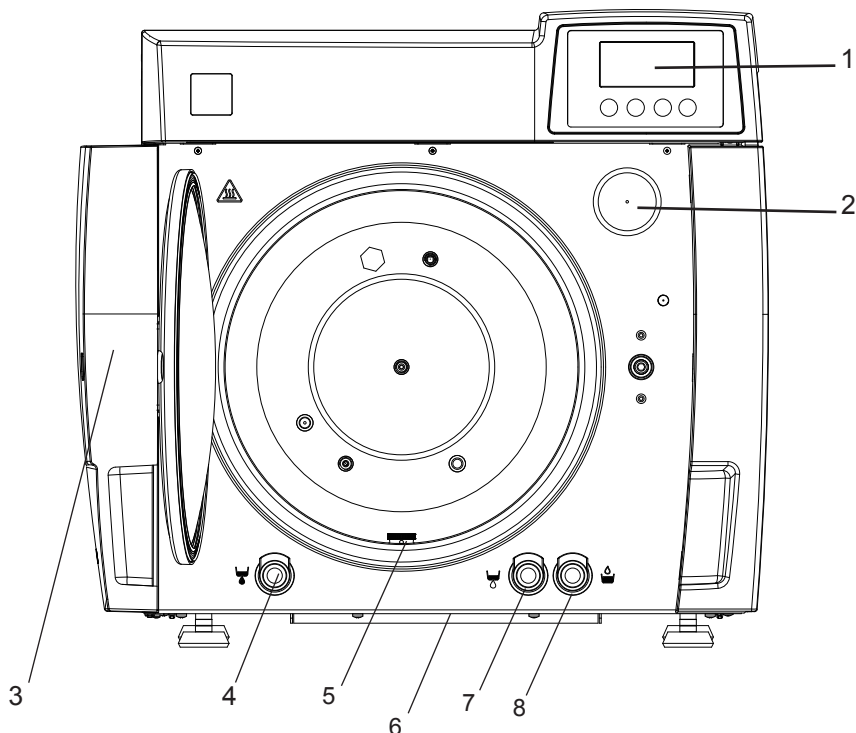
CS

Ref.	Popis přístroje
1	Ovládací panel s displejem LCD (DISPLAY TOUCH SCREEN)
2	Antibakteriální filtr
3	Dvířka
4	Rychlospojka na vypouštění použité vody
5	Filtr na odtoku vody
6	Prachový filtr
7	Rychlospojka na vypouštění destilované vody z nádrže (POUZE SERVIS)
8	Rychlospojka pro doplňování destilované vody

NL

Ref.	Beschrijving toestel
1	Bedieningspaneel en display LCD (DISPLAY TOUCH SCREEN)
2	Bacteriologische filter
3	Luik
4	Snelkoppeling van gebruikt waterafvoer
5	Filter waterafvoer
6	Stoffilter
7	Snelkoppeling van afvoer tank gedistilleerd water (ALLEEN SERVICE)
8	Snelkoppeling bijvullen gedistilleerd water

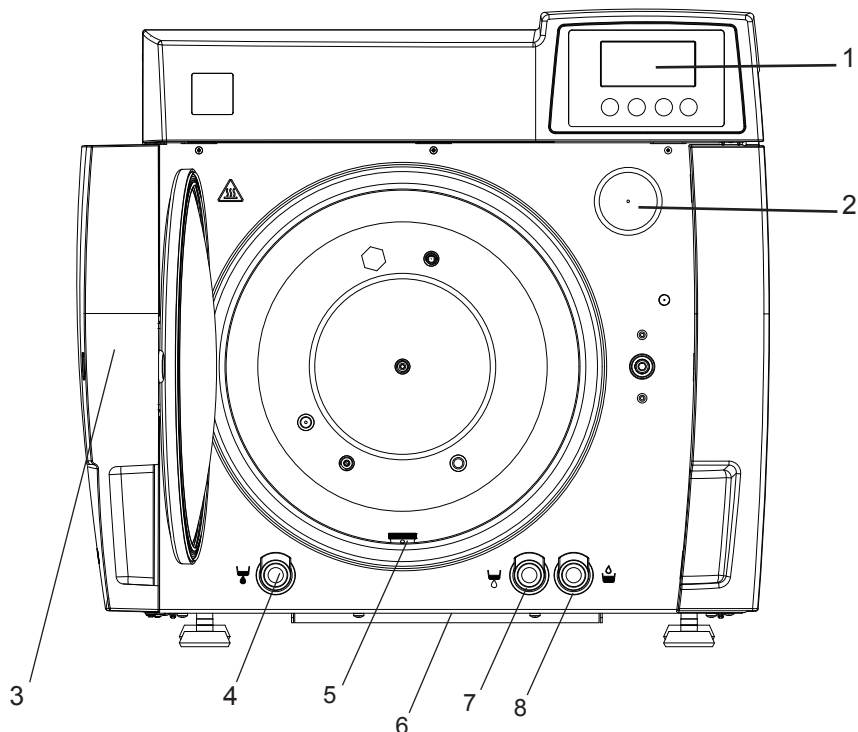

EL

Σχετ.	Περιγραφή Συσκευής
1	Πίνακας χειριστηρίων και οθόνη LCD (DISPLAY TOUCH SCREEN)
2	Βακτηριολογικό φίλτρο
3	Θυρίδα
4	Ταχυσύνδεσμος εκκένωσης χρησιμοποιηθέντος νερού
5	Φίλτρο εκκένωσης νερού
6	Φίλτρο συγκράτησης σκόνης
7	Ταχυσύνδεσμος εκκένωσης ρεζερβουάρ απεσταγμένου νερού (MONO SERVICE)
8	Ταχυσύνδεσμος συμπλήρωσης απεσταγμένου νερού

RU

Ссылка	Описание Устройства
1	Панель управления с дисплеем LCD (ДИСПЛЕЙ TOUCH SCREEN)
2	Бактериологический фильтр
3	Дверь
4	Быстросъемный соединитель слива использованной воды
5	Фильтр опорожнения воды
6	Противопылевой фильтр
7	Быстросъемный соединитель опорожнения бака дистиллированной воды (только SERVICE)
8	Быстрое соединение пополнения дистиллированной воды

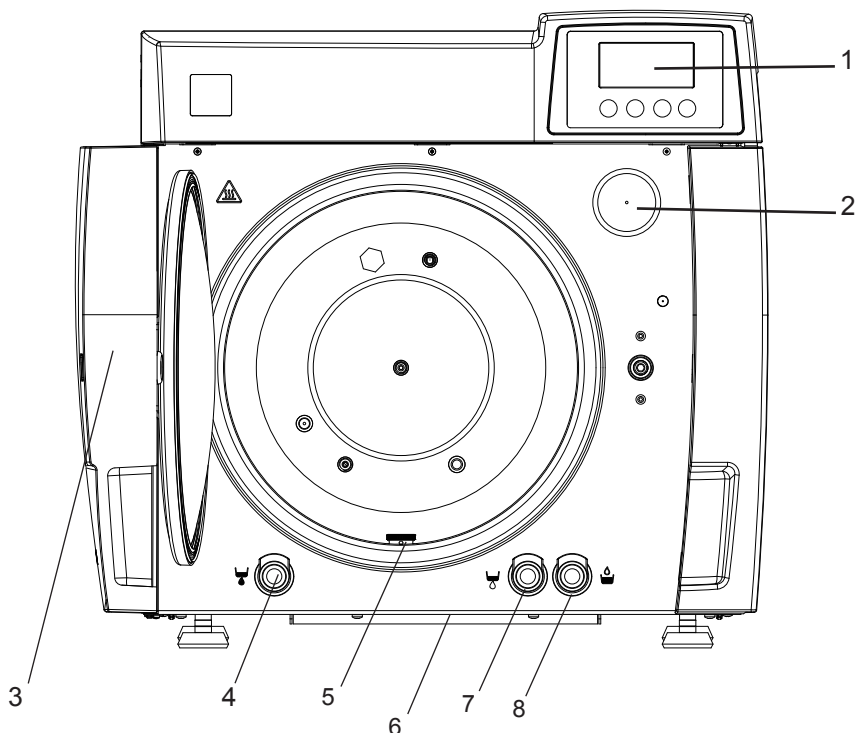
PT

Ref.	Descrição do aparelho
1	Painel de comandos e ecrã LCD (DISPLAY TOUCH SCREEN)
2	Filtro bacteriológico
3	Porta
4	Conexão rápida de descarga da água usada
5	Filtro de descarga da água
6	Filtro antipó
7	Conexão rápida de descarga do depósito de água destilada (APENAS SERVICE)
8	Conexão rápida para enchimento com água destilada

SV

Ref.	Beskrivning Apparat
1	Manöverpanel och skärm LCD (DISPLAY PEKSKÄRM)
2	Bakteriefilter
3	Lucka
4	Snabbkoppling dränering använt vatten
5	Filter dränering vatten
6	Dammfilter
7	Snabbkoppling dränering behållare destillerat vatten: (ENDAST SERVICE)
8	Snabbkoppling påfyllning destillerat vatten

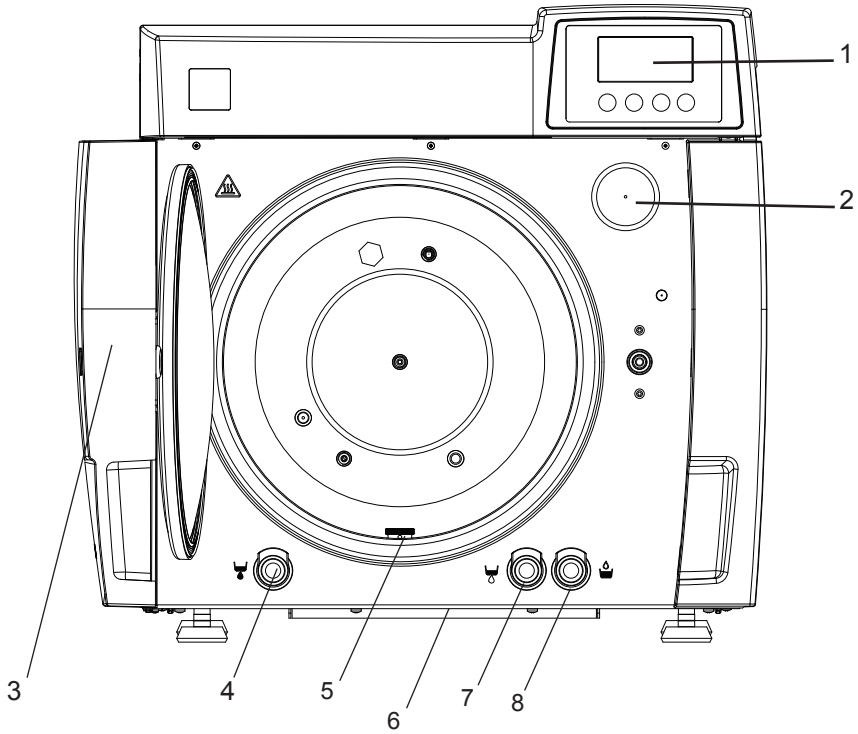

FI

Rif.	Laitteen kuvaus
1	Ohjauspaneeli ja LCD-näyttö (KOSKETUSNÄYTTÖ)
2	Bakteerisuodatin
3	Ovi
4	Pikaliitin käytetyn veden poistoon
5	Vedenpoistosuodatin
6	Pölynpoistosuodatin
7	Pikaliitin tislattun veden poistoon säiliöstä (VAIN HUOLTO)
8	Pikaliitin tislattun veden täyttöle

AR

رقم جزء	زاجل فصر
1	LCD ضرع تشاشو رم اوالا ءحول (سجل اب لم عت ضرع تشاش)
2	ي جولو ويرت ككب رتلف
3	ءءءءف
4	فرصل ءعيرس طبر ءلصو مءءءسءءل اءءل
5	ءءءل فرصل رتلف
6	رءب ءلل ءءءم رتلف
7	ءءءل اءءم فرصل ءعيرس طبر ءلصو (طءف مءءءل) طرءءل
8	طرءءل اءءل ءءءءل ءعيرس ءلصو

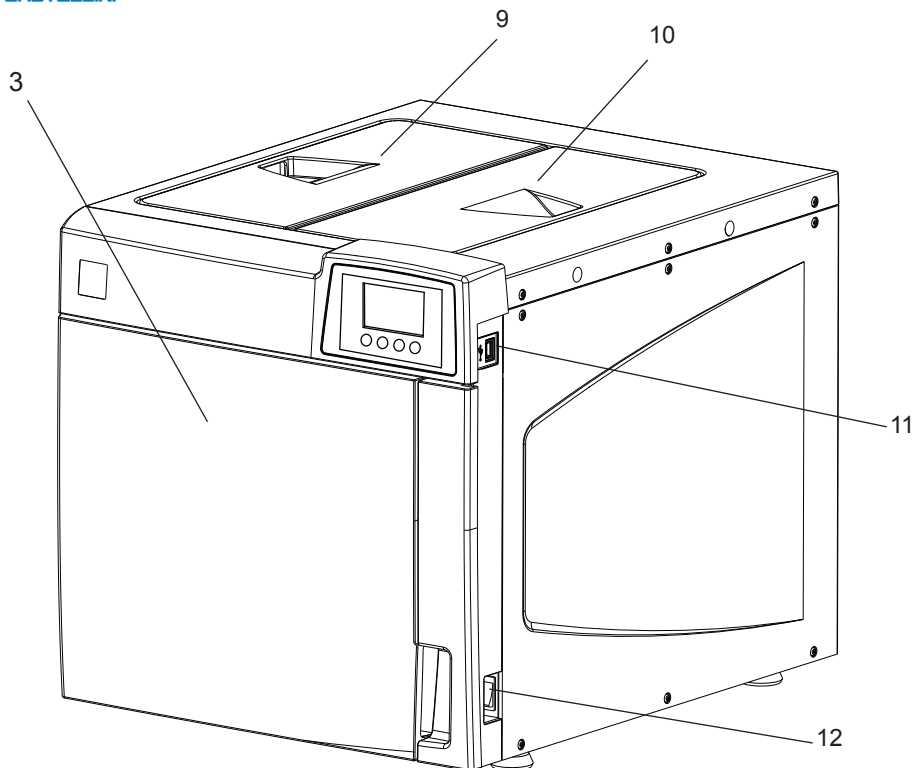
IT

Rif.	Descrizione Apparecchio
3	Portello
9	Serbatoio scarico
10	Serbatoio carico
11	Porta USB
12	Interruttore accensione

EN

Ref.	Device description
3	Door
9	Drain tank
10	Filling tank
11	USB port
12	Power switch

FR

Réf.	Description appareil
3	Trappe
9	Réservoir de vidange
10	Réservoir de remplissage
11	Port USB
12	Interrupteur d'allumage

DE

Ref.	Beschreibung des Geräts
3	Türklappe
9	Abwassertank
10	Befülltank
11	USB-Port
12	Schalter zum Einschalten

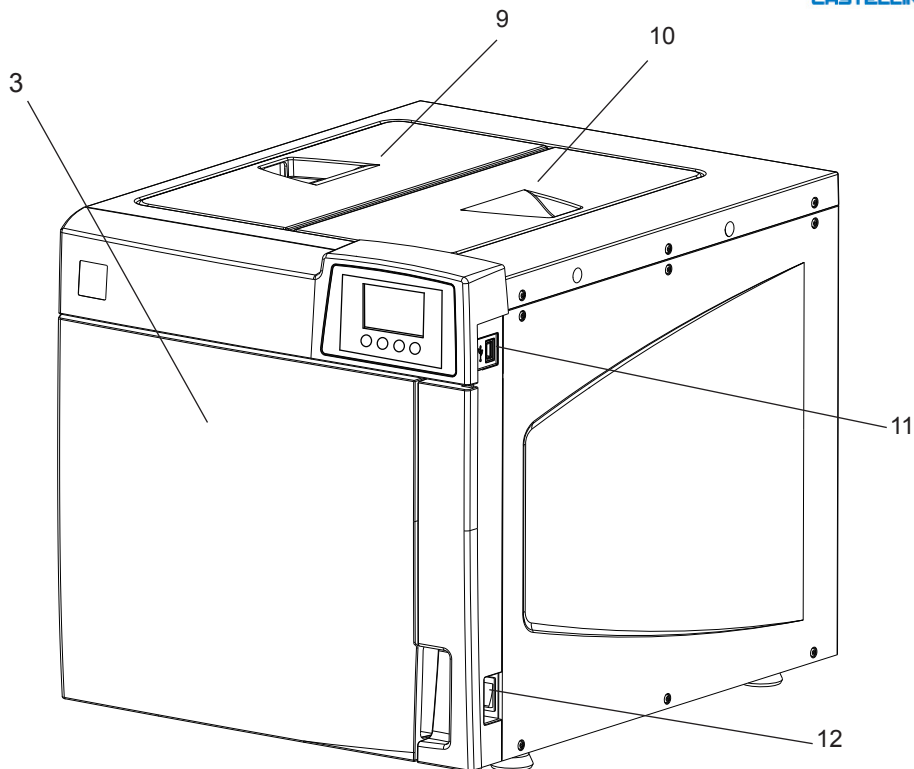
ES

Ref.	Descripción Aparato
3	Puerta
9	Depósito de desagüe
10	Depósito de carga
11	Puerto USB
12	Interruptor de encendido

PL

Odn.	Opis urządzenia
3	Drzwiczki
9	Zbiornik ładunkowy
10	Zbiornik rozładunkowy
11	Port USB
12	Wyłącznik załączający

TR

Bkz.	Cihazın Tanımlanması
3	Kapak
9	Boşaltma deposu
10	Doldurma deposu
11	USB Port
12	Açma düğmesi

NO

Ref.	Beskrivelse Apparat
3	Luke
9	Tom beholder
10	Full beholder
11	USB tilkobling
12	Oppstartbryter

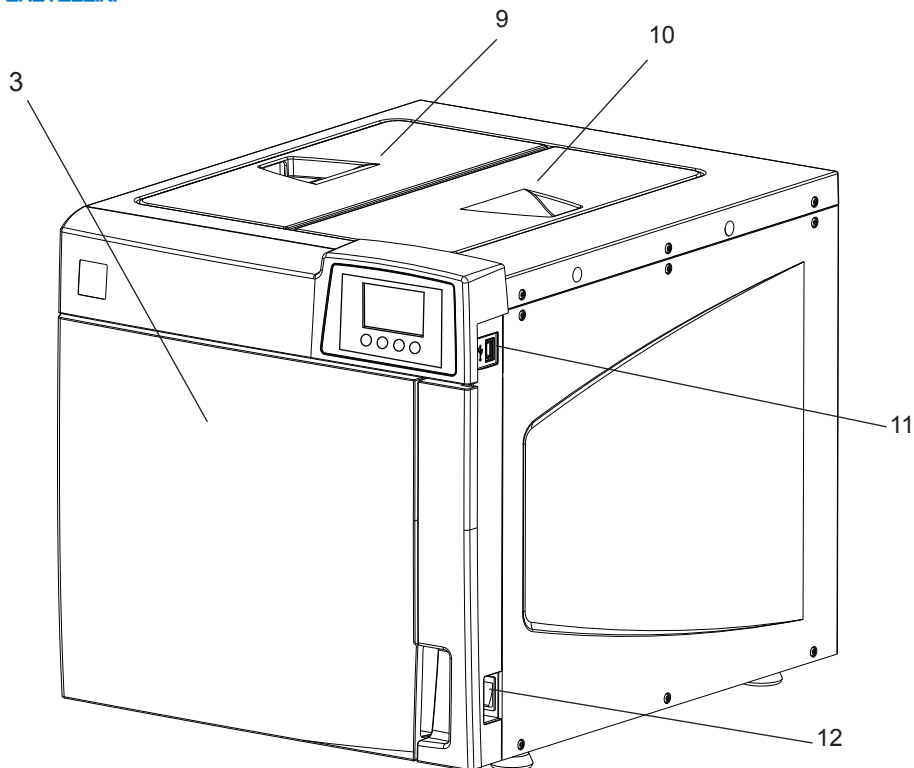
CS

Ref.	Popis přístroje
3	Dvřítka
9	Vypouštěcí nádrž
10	Napouštěcí nádrž
11	Port USB
12	Vypínač

NL

Ref.	Beschrijving toestel
3	Luik
9	Tank afvoer
10	Tank toevoer
11	USB port
12	Schakelaar aanschakeling

EL

Σχετ.	Περιγραφή Συσκευής
3	Θυρίδα
9	Δεξαμενή εκκένωσης
10	Δεξαμενή τροφοδοσίας
11	Θύρα USB
12	Διακόπτης ανάμματος

RU

Ссылка	Описание Устройства
3	Дверь
9	Пустой бак
10	Полный бак
11	Порт USB
12	Выключатель

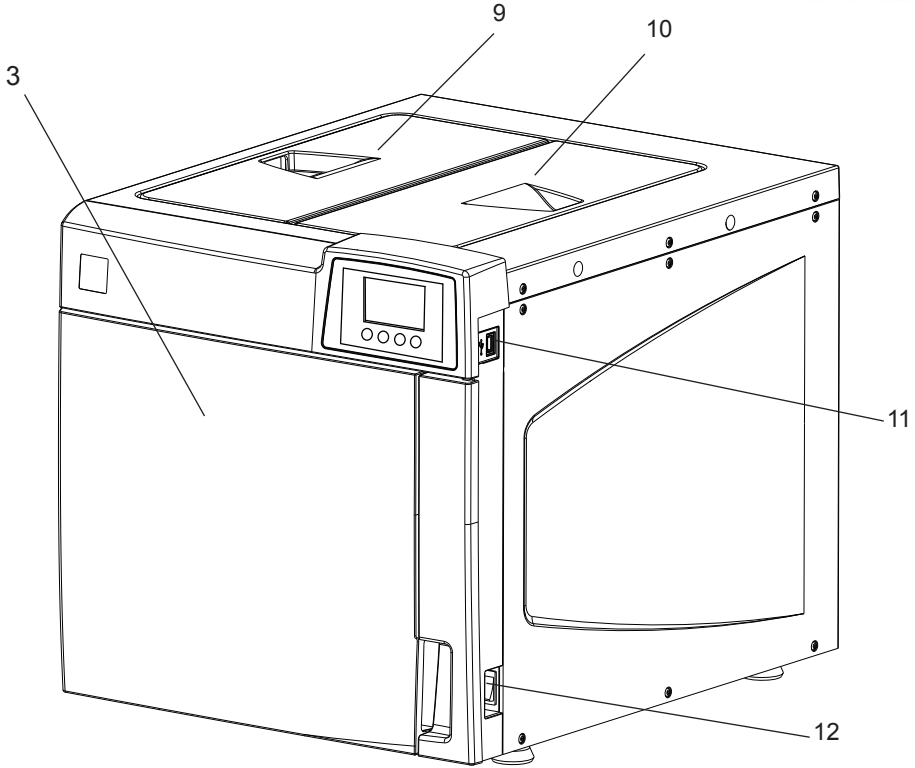
PT

Ref.	Descrição do aparelho
3	Porta
9	Depósito de descarga
10	Depósito de carga
11	Porta USB
12	Interruptor liga/desliga

SV

Ref.	Beskrivning Apparat
3	Lucka
9	Behållare tillopp
10	Behållare dränering
11	USB port
12	Strömbrytare tändning

FI

Rif.	Laitteen kuvaus
3	Ovi
9	Poistosäiliö
10	Täyttösäiliö
11	USB-portti
12	Käynnistyskytkin

AR

زاهج رم	زاهج الفصو
3	ةحتف
9	غراف نازخ
10	ءيلم نازخ
11	(ماعلا يلسلسئلا لقانلا) USB ذفنم
12	ليغئئئلا حاتفم

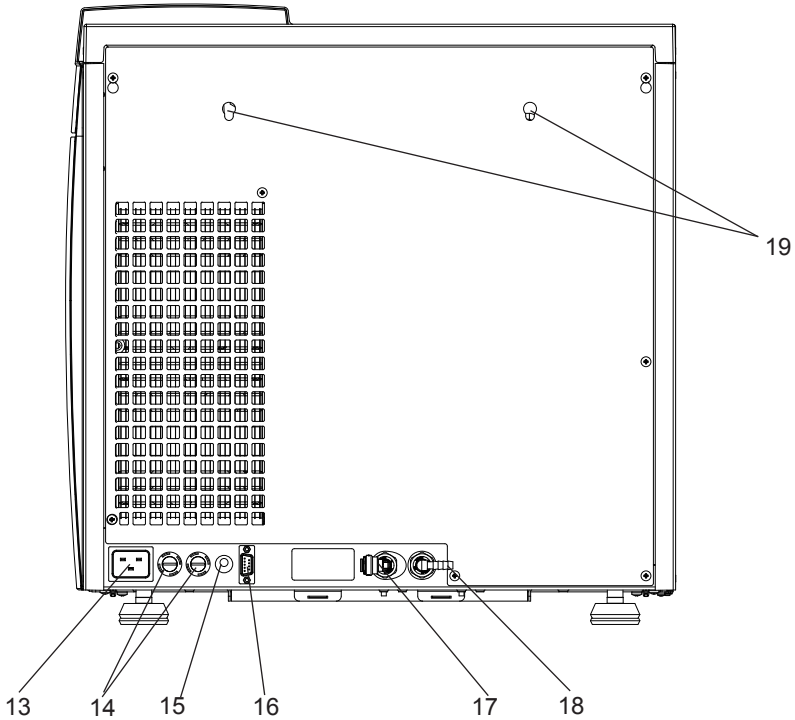
IT

Rif.	Descrizione collegamenti elettrici ed idraulici
13	Connessione cavo di alimentazione
14	Fusibili di rete
15	Connessione elettrica carico esterno
16	Connessione cavo seriale
17	Carico
18	Scarico
19	Asole di fissaggio per distanziali posteriori

EN

Ref.	Description of electrical and hydraulic connections
13	Power cable connection
14	Mains fuses
15	External filling electrical connection
16	Serial cable connection
17	Inlet
18	Outlet
19	Mounting holes for rear spacer

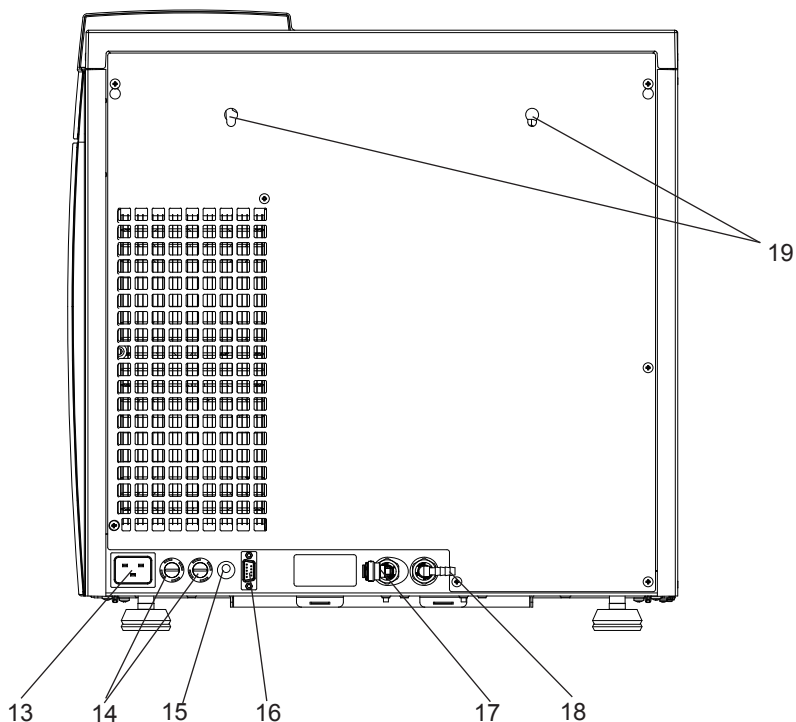
FR

Réf.	Description connexions électriques et hydrauliques
13	Connexion câble d'alimentation
14	Fusibles de réseau
15	Connexion électrique de remplissage extérieur
16	Connexion câble sériel
17	Remplissage
18	Vidange
19	Trous de fixation pour l'entretoise arrière

DE

Ref.	Beschreibung der elektrischen und hydraulischen Anschlüsse
13	Anschluss des Netzkabels
14	Netzsicherungen
15	Elektrischer Anschluss für externe Befüllung
16	Anschluss für serielles Kabel
17	Befüllung
18	Ablass
19	Bohrungen für hintere Abstandshalter

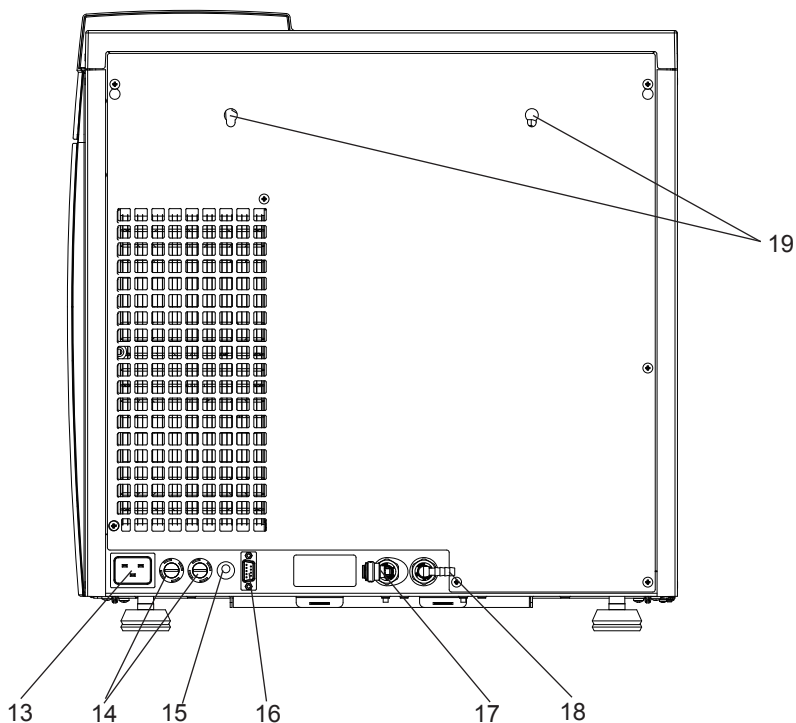
ES

Ref.	Descripción conexiones eléctricas e hidráulicas
13	Conexión cable de alimentación
14	Fusibles de red
15	Conexión eléctrica carga externa
16	Conexión cable serie
17	Carga
18	Desagüe
19	Agujeros de montaje para espaciador trasero

PL

Odn.	Opis połączeń elektrycznych i hydraulicznych
13	Podłączenie kabla zasilającego
14	Bezpieczniki sieciowe
15	Podłączenie elektryczne ładunek zewnętrzny
16	Podłączenie kabla szeregowego
17	Ładunek
18	Wyładunek
19	Otwory montażowe na tylnej spacer

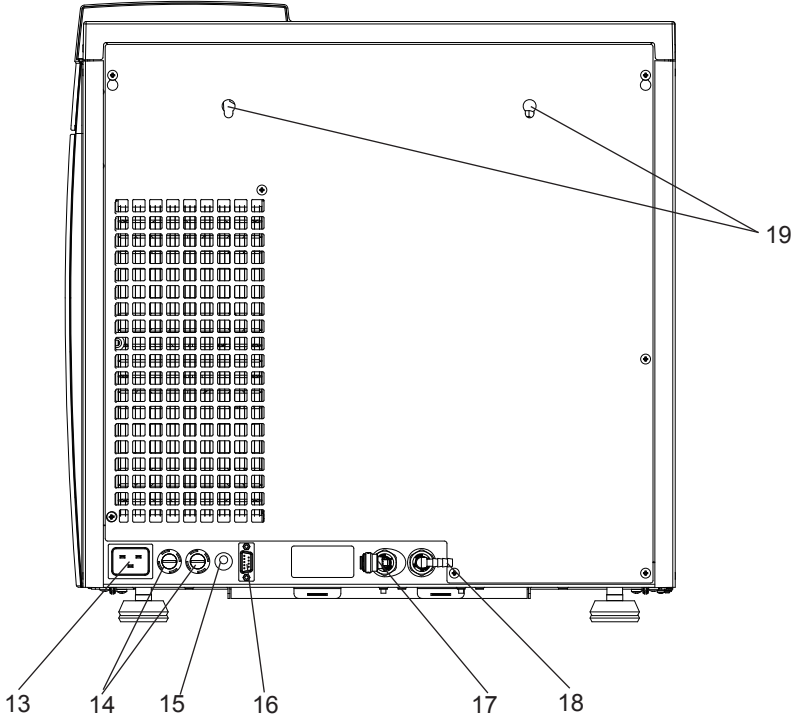

TR

Bkz.	Elektrik ve su bağlantılarıyla ilgili açıklama
13	Besleme kablosu bağlantısı
14	Şebeke sigortaları
15	Dış yük elektrik bağlantısı
16	Seri kablo bağlantısı
17	Doldurma
18	Boşaltma
19	Arka ayırıcı için montaj delikleri

NO

Ref.	Beskrivelse av elektriske og hydrauliske tilkoblinger
13	Tilkoblingskabel for Strømforsyning
14	Nettsikringer
15	Tilkobling ekstern elektrisk forsyning
16	Tilkobling seriekabel
17	Last
18	Lossing
19	Monteringshull for bakre spacer

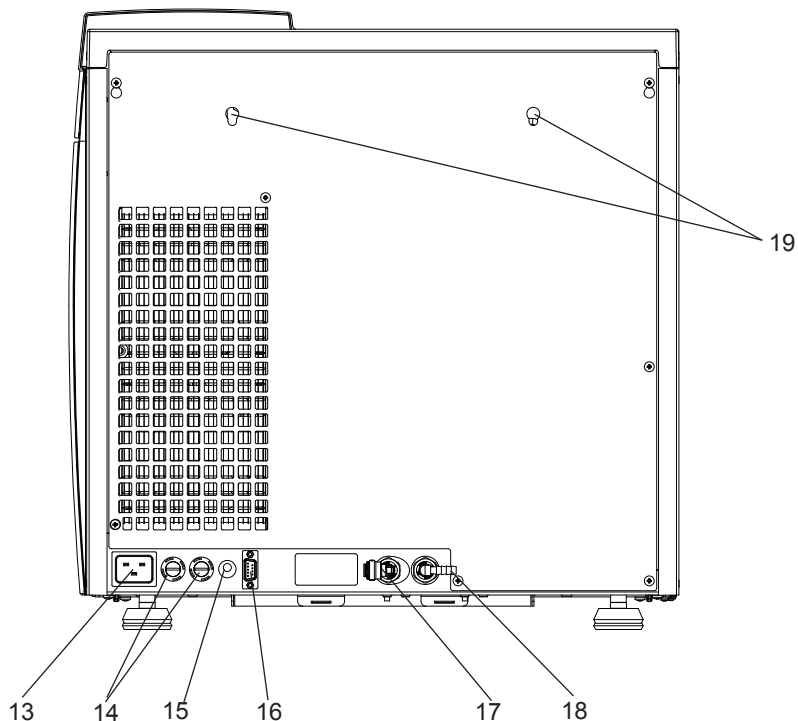
CZ

Ref.	Popis elektrického e vodního obvodu
13	Připojení přívodní šňůry
14	Pojistky sítě
15	Elektrické připojení na vnější síť
16	Připojení sériového vodiče
17	Napouštění
18	Vypouštění
19	Montážní otvory pro zadní spacer

NL

Ref.	Beschrijving elektrische en hydraulische verbindingen
13	Aansluiting voedingskabel
14	Zekeringen van het net
15	Elektrische aansluiting externe afvoer
16	Aansluiting seriële kabel
17	Toevoer
18	Afvoer
19	Bevestigingsgaten voor afstandshoeken

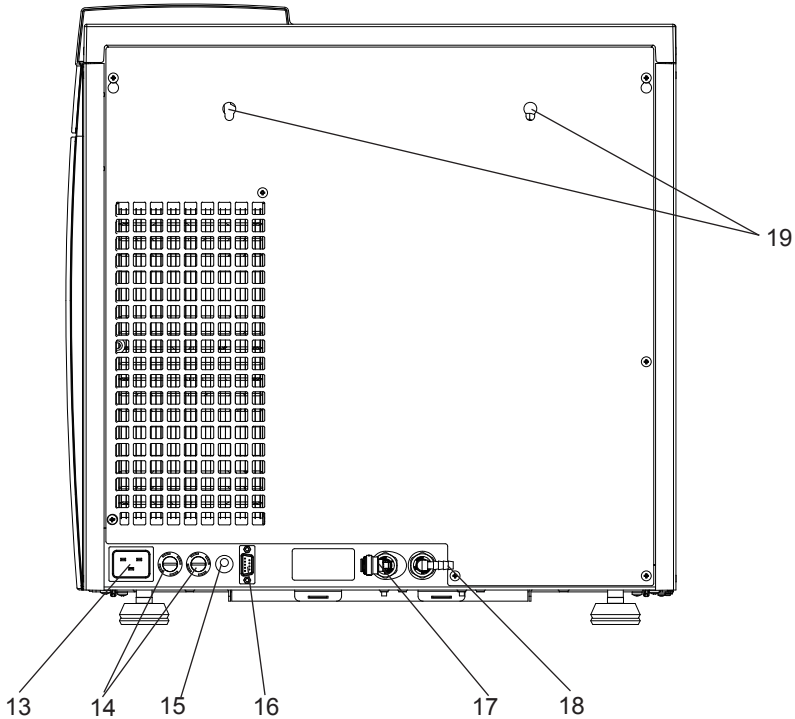

EL

Σχετ.	Περιγραφή ηλεκτρικών και υδραυλικών συνδέσεων
13	Σύνδεση καλωδίου τροφοδοσίας
14	Ασφάλειες δικτύου
15	Ηλεκτρική σύνδεση εξωτερικής τροφοδοσίας
16	Σύνδεση σειριακού καλωδίου
17	Τροφοδοσία
18	Εκκένωση
19	Οπές στερέωσης για τα οπίσθια διαχωριστική

RU

Ссылка	Описание электрических и гидравлических соединений
13	Подключение токоподводящего кабеля
14	Предохранители сети
15	Электрическое подключение внешнего наполнения
16	Последовательное соединение
17	Наполнение
18	Опустошение
19	монтажные отверстия для задних Spacer

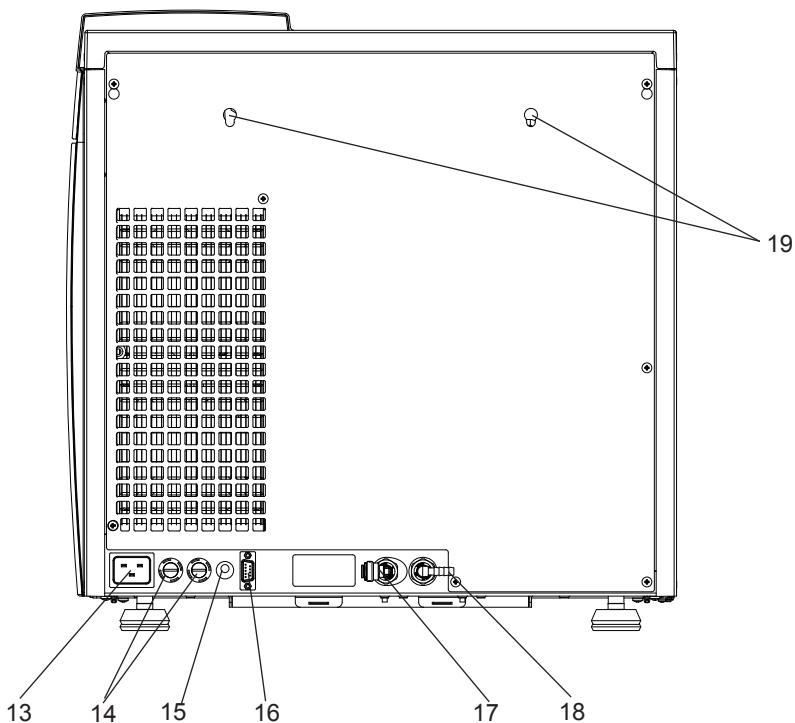
PT

Ref.	Descrição das ligações elétricas e hidráulicas
13	Conexão do cabo de alimentação
14	Fusíveis de rede
15	Conexão elétrica de carga externa
16	Conexão do cabo série
17	Carga
18	Descarga
19	Furos de montagem para espaçador traseiro

SV

Ref.	Beskrivning elektriska och hydrauliska anslutningar
13	Koppling strömkabel
14	Säkringar för nätet
15	Elektrisk koppling externt tillopp
16	Koppling serialkabel
17	Tillopp
18	Dränering
19	Monteringshål för bakre spacer

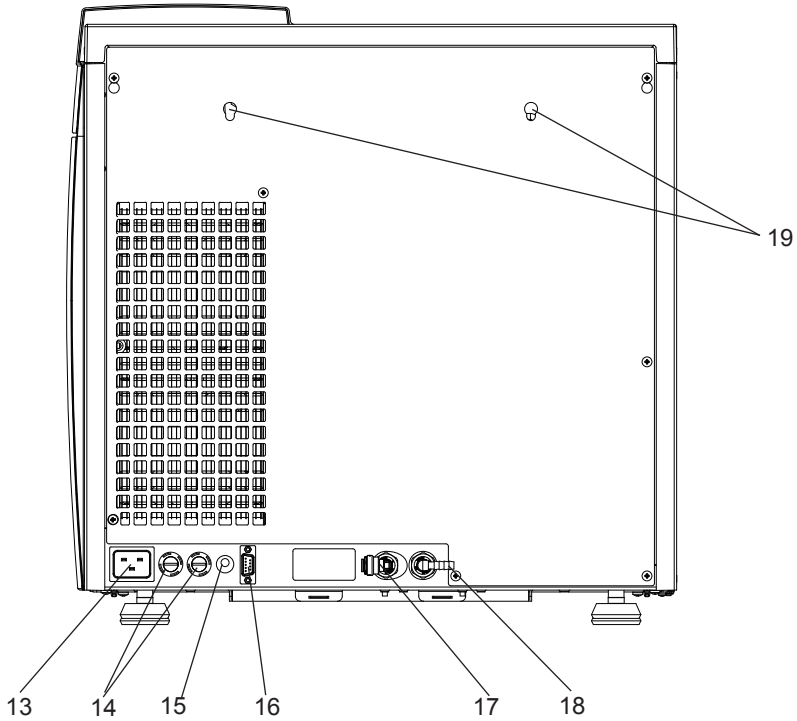

FI		AR	
Rif.	Sähkö- ja hydrauliliitännöjen kuvaus	عجم	ةي ئابرهكل تال ي صوتلا فصول ةي كي لوردي مل او
13	Syöttöjohdon liitäntä	13	ةي ذغتل لبك لي صوت
14	Verkkosulakkeet	14	(تارصن مل) رايتلا عطاوق
15	Ulkoisen täytön sähköliitäntä	15	ةي جراخ ن حش ي ئابرهك لي صوت
16	Sarjakaapelin liitäntä	16	يل س لسرتلا لبكلا لي صوت
17	Täyttö	17	ن حش
18	Poisto	18	غ يرفت
19	Ruuvikanavat takana spacer	19	يفلخ ل صرافلل ةدياز تمل بوقثلا

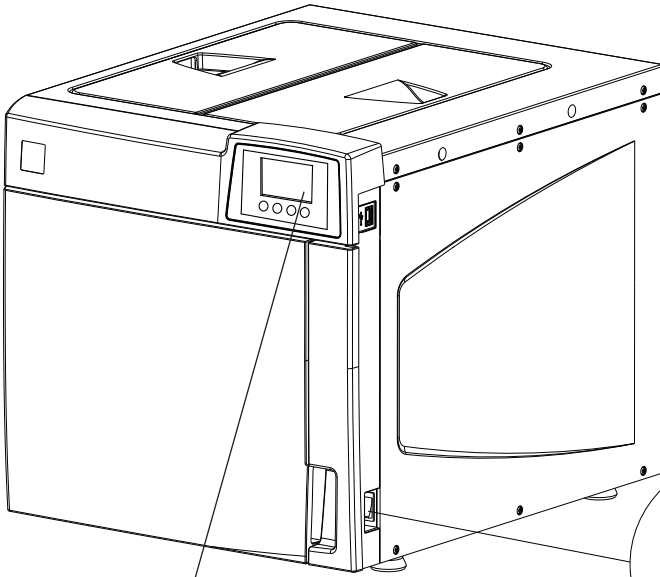

BEEP

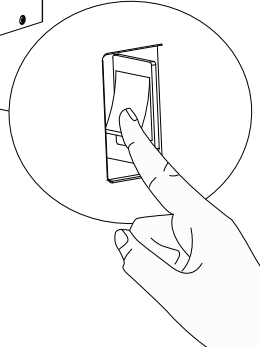

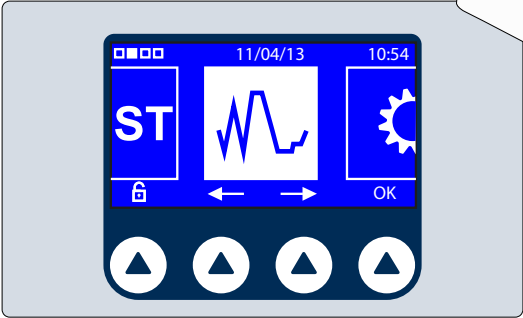
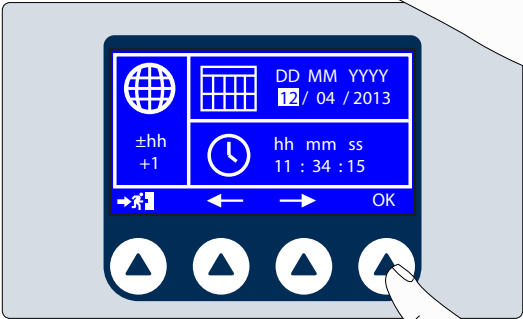



H₂O
MAX 15 µS/cm



BEEP

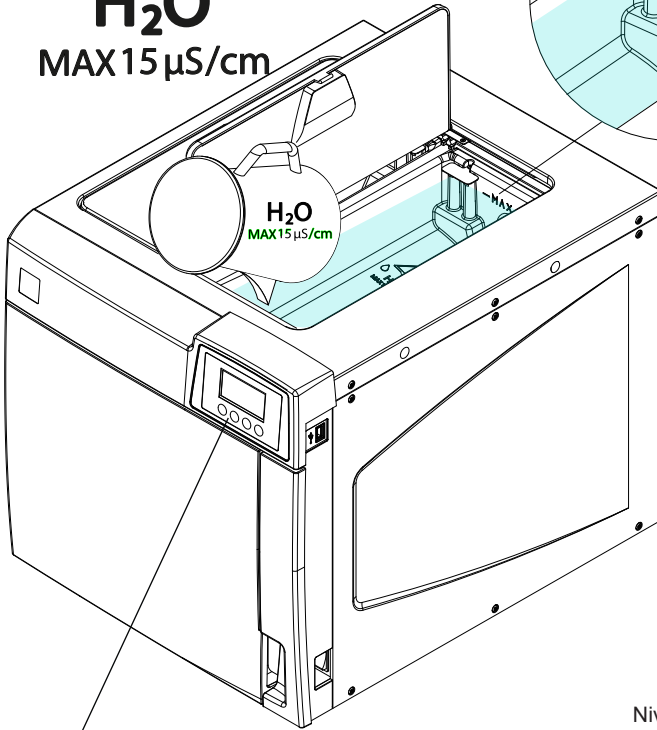
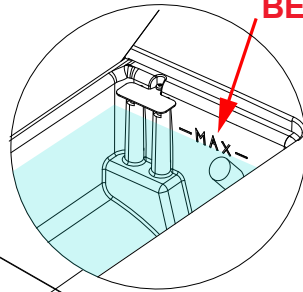



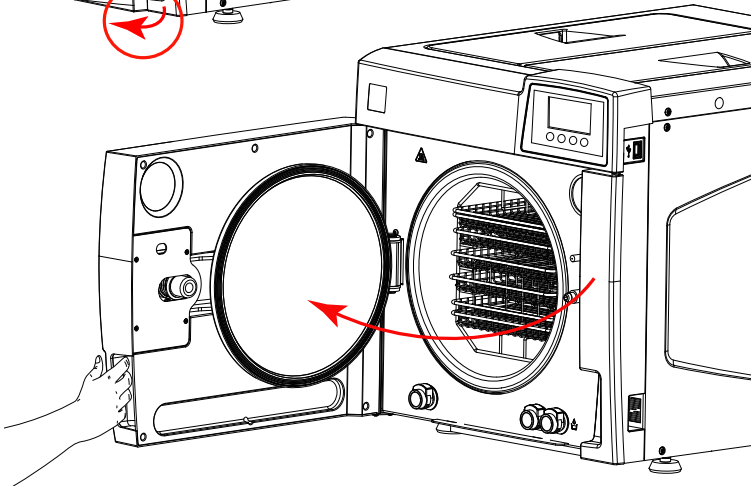
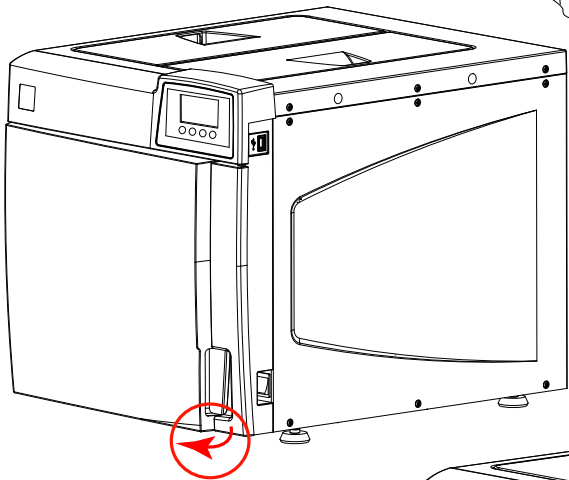
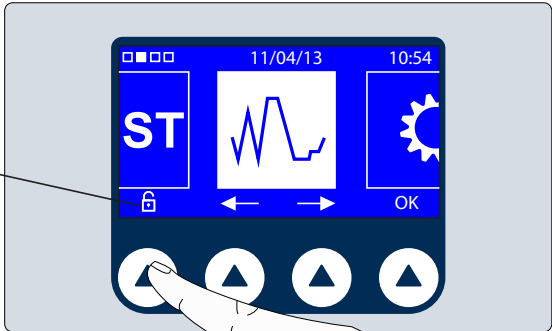



Livello Carico Max
 Max filling level
 Niveau de rempl. maxi
 Max. Befüllungsstand
 Nivel máximo de carga
 Maksymalny poziom ładowania
 Seviye Max Yük
 Nivá Max Load
 Úroveň Maximální zatížení
 Niveau Maximum Lading
 Επίπεδο Μέγιστο φορτίο
 Уровень нагрузки Max
 Nivel máx
 Nivá Maxlast
 Taso Max Load
 يوصقلا ؤلومحلا يوتسم





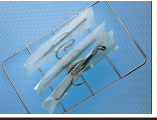

IT

CICLI	TIPOLOGIA CARICO	MAX KG			
		17S	17	22	
B 134°C Universale B 121°C Universale B 134°C Prione	Materiali porosi non confezionati		-	1,00	1,25
	Materiali porosi in confezione singola		-	0,75	1,00
	Materiali porosi in confezione doppia		-	0,60	0,75
	Materiali solidi e cavi in confezione singola		-	3,00	4,00
	Strumenti solidi e cavi in confezione doppia		-	1,50	2,00
S 134°C Cavi	Strumenti cavi non confezionati		-	6,00	7,50
S 134°C Solidi	Strumenti solidi e cavi "B" non confezionati		6,00	6,00	7,50
	Strumenti solidi e cavi "B" con imballo singolo		3,00	3,00	4,00
S 121°C Solidi S 134°C Prione	Strumenti solidi e cavi "B" con imballo singolo		3,00	-	-
N 134°C Solidi N 121°C Solidi	Strumenti solidi e cavi "B" non confezionati		6,00	-	-

CYCLES	TYPE OF LOAD		MAX KG		
			17S	17	22
B 134°C Universal B 121°C Universal B 134°C Prion	Unwrapped porous materials		-	1,00	1,25
	Porous materials in single package		-	0,75	1,00
	Porous materials in double package		-	0,60	0,75
	Solid and hollow materials in single package		-	3,00	4,00
	Solid and hollow instruments in double package		-	1,50	2,00
S 134°C Hollow	Hollow instruments not wrapped		-	6,00	7,50
S 134°C Solid	Solid instruments and hollow instruments "B" not wrapped		6,00	6,00	7,50
	Solid instruments and hollow instruments "B" in single package		3,00	3,00	4,00
S 121°C Solid S 134°C Prion	Solid instruments and hollow instruments "B" in single package		3,00	-	-
N 134°C Solid N 121°C Solid	Solid instruments and hollow instruments "B" not wrapped		6,00	-	-

FR

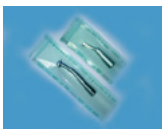
CYCLES	TYPE DE CHARGEMENT	KG MAXI			
		17S	17	22	
B 134°C Universel B 121°C Universel B 134°C Prion	Matériels poreux non emballés		-	1,00	1,25
	Matériels poreux en emballage individuel		-	0,75	1,00
	Matériels poreux en emballage double		-	0,60	0,75
	Matériels solides et creux en emballage individuel		-	3,00	4,00
	Instruments solides et creux en emballage double		-	1,50	2,00
S 134°C Creux	Instruments creux non emballés		-	6,00	7,50
S 134°C Solides	Instruments solides, instruments creux "B" non emballés		6,00	6,00	7,50
	Instruments solides, instruments creux "B" avec emballage individuel		3,00	3,00	4,00
S 121°C Solides S 134°C Prion	Instruments solides, instruments creux "B" avec emballage individuel		3,00	-	-
N 134°C Solides N 121°C Solides	Instruments solides, instruments creux "B" non emballés		6,00	-	-

ZYKLEN	ART DES STERILISIERGUTS		MAX KG		
			17S	17	22
B 134°C Universal B 121°C Universal B 134°C Prion	Unverpacktes poröses Material		-	1,00	1,25
	Poröses Material in Einzelverpackung		-	0,75	1,00
	Poröses Material in Doppelverpackung		-	0,60	0,75
	Massives und hohles Material in Einzelverpackung		-	3,00	4,00
	Massive und hohle Instrumente in Doppelverpackung		-	1,50	2,00
S 134°C Hohl	Unverpackte hohle Instrumente		-	6,00	7,50
S 134°C Massiv	Unverpackte massive Instrumente, hohle Instrumente "B"		6,00	6,00	7,50
	Massive Instrumente, hohle Instrumente "B" in Einzelverpackung		3,00	3,00	4,00
S 121°C Massiv S 134°C Prion	Massive Instrumente, hohle Instrumente "B" in Einzelverpackung		3,00	-	-
N 134°C Massiv N 121°C Massiv	Unverpackte massive Instrumente, hohle Instrumente "B"		6,00	-	-

ES

CICLOS	TIPOLOGÍA DE CARGA	MÁX KG			
		17S	17	22	
B 134°C Universal	Materiales porosos sin envoltorio		-	1,00	1,25
	Materiales porosos en envase individual		-	0,75	1,00
B 121°C Universal	Materiales porosos en envase doble		-	0,60	0,75
B 134°C Prión	Materiales sólidos y huecos en envase individual		-	3,00	4,00
	Instrumentos sólidos y huecos en envase doble		-	1,50	2,00
S 134°C Huecos	Instrumentos huecos sin envoltorio		-	6,00	7,50
S 134°C Sólidos	Instrumentos sólidos, instrumentos huecos "B" sin envoltorio		6,00	6,00	7,50
	Instrumentos sólidos, instrumentos huecos "B" en envase individual		3,00	3,00	4,00
S 121°C Sólidos S 134°C Prión	Instrumentos sólidos, instrumentos huecos "B" en envase individual		3,00	-	-
N 134°C Sólidos N 121°C Sólidos	Instrumentos sólidos, instrumentos huecos "B" sin envoltorio		6,00	-	-

CYKLE	RODZAJ ZAŁADUNKU		MAX KG		
			17S	17	22
B 134°C Uniwersalny B 121°C Uniwersalny B 134°C Prion	Materiały porowate nieopakowane		-	1,00	1,25
	Materiały porowate pakowane pojedynczo		-	0,75	1,00
	Materiały porowate w podwójnym opakowaniu		-	0,60	0,75
	Materiały lite i wgłębione w pojedynczym opakowaniu		-	3,00	4,00
	Narzędzia lite i wgłębione w podwójnym opakowaniu		-	1,50	2,00
S 134°C Wgłębione	Narzędzia wgłębione nieopakowane		-	6,00	7,50
S 134°C Lite	Narzędzia lite, Narzędzia wgłębione "B" nieopakowane		6,00	6,00	7,50
	Narzędzia lite, Narzędzia wgłębione "B" w pojedynczym opakowaniu		3,00	3,00	4,00
S 121°C Lite S 134°C Prion	Narzędzia lite, Narzędzia wgłębione "B" w pojedynczym opakowaniu		3,00	-	-
N 134°C Lite N 121°C Lite	Narzędzia lite, Narzędzia wgłębione "B" nieopakowane		6,00	-	-

TR

DÖNGÜLER	DOLDURULAN MALZEMELERİN TÜRÜ	AZAMI KG		
		17S	17	22
B 134°C Evrensel	Ambalajlanmamış gözenekli malzemeler	-	1,00	1,25
	Tekli ambalajda gözenekli malzemeler	-	0,75	1,00
B 121°C Evrensel	Çiftli ambalajda gözenekli malzemeler	-	0,60	0,75
	Tekli ambalajda katı malzemeler ve kablolar	-	3,00	4,00
B 134°C Prion	Çiftli ambalajda katı aletler ve kablolar	-	1,50	2,00
S 134°C Boşluk	Ambalajlanmamış aletler ve kablolar	-	6,00	7,50
S 134°C Katı	Ambalajlanmamış katı aletler içi boş araçlar "B" dolu değil	6,00	6,00	7,50
	Tekli ambalajlı katı aletler içi boş araçlar "B" tek bir paket	3,00	3,00	4,00
S 121°C Katı	Tekli ambalajlı katı aletler içi boş araçlar "B" tek bir paket	3,00	-	-
S 134°C Prion				
N 134°C Katı	Ambalajlanmamış katı aletler içi boş araçlar "B" dolu değil	6,00	-	-
N 121°C Katı				

SYKLUSER	TYPE LAST		MAX KG		
			17S	17	22
B 134°C Universell	Porøse ikke-konfeksjonerte materialer		-	1,00	1,25
	Porøse materialer i enkelt konfeksjon		-	0,75	1,00
B 121°C Universell	Porøse materialer i dobbel konfeksjon		-	0,60	0,75
B 134°C Prioner	Solide og hule materialer i enkel konfeksjon		-	3,00	4,00
	Solide og hule instrumenter i dobbel konfeksjon		-	1,50	2,00
S 134°C Hul	Ikke-konfeksjonerte hule instrumenter		-	6,00	7,50
S 134°C Fast	Solide instrumenter og kabler "B" er ikke pakket		6,00	6,00	7,50
	Solide instrumenter og kabler "B" med individuell emballasje		3,00	3,00	4,00
S 121°C Fast	Solide instrumenter og kabler "B" med individuell emballasje		3,00	-	-
S 134°C Prioner					
N 134°C Fast	Solide instrumenter og kabler "B" er ikke pakket		6,00	-	-
N 121°C Fast					

CZ

CYKLY	POPIS OBSAHU		MAX KG		
			17S	17	22
B 134°C Univerzální B 121°C Univerzální B 134°C Prione	Nebalené porózní materiály		-	1,00	1,25
	Porózní jednotlivě balené materiály		-	0,75	1,00
	Porózní po dvou balené materiály		-	0,60	0,75
	Tuhé a duté materiály jednotlivě balené		-	3,00	4,00
	Tuhé a duté nástroje po dvou balené		-	1,50	2,00
S 134°C Duté	Duté nebalené nástroje		-	6,00	7,50
S 134°C Tuhé	Pevné přístroje a kabely "B" není balené		6,00	6,00	7,50
	Pevné přístroje a kabely "B" s individuálním balení		3,00	3,00	4,00
S 121°C Tuhé S 134°C Prione	Pevné přístroje a kabely "B" s individuálním balení		3,00	-	-
N 134°C Tuhé N 121°C Tuhé	Pevné přístroje a kabely "B" není balené		6,00	-	-





CYCLI	TYPOLOGIE TOEVOER		MAX KG		
			17S	17	22
B 134°C Universele B 121°C Universele B 134°C Prion	Niet verpakte poreuze materialen		-	1,00	1,25
	Poreuze materialen in enkele verpakking		-	0,75	1,00
	Poreuze materialen in dubbele verpakking		-	0,60	0,75
	Vaste materialen en kabels in enkele verpakking		-	3,00	4,00
	Vaste instrumenten en kabels in dubbele verpakking		-	1,50	2,00
S 134°C Kabels	Niet verpakte instrumenten kabels		-	6,00	7,50
S 134°C Vaste	Stevige instrumenten en kabels "B" is niet verpakt		6,00	6,00	7,50
	Stevige instrumenten en kabels "B" met individuele verpakking		3,00	3,00	4,00
S 121°C Vaste S 134°C Prion	Stevige instrumenten en kabels "B" met individuele verpakking		3,00	-	-
N 134°C Vaste N 121°C Vaste	Stevige instrumenten en kabels "B" is niet verpakt		6,00	-	-





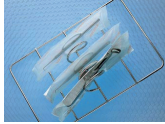

EL

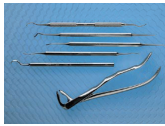
ΚΥΚΛΟΙ	ΤΥΠΟΛΟΓΙΑ ΤΡΟΦΟΔΟΣΙΑΣ	MAX KG		
		17S	17	22
B 134°C Universal	Υλικά πορώδη μη συσκευασμένα	-	1,00	1,25
	Υλικά πορώδη σε ατομική συσκευασία	-	0,75	1,00
B 121°C Universal	Υλικά πορώδη σε διπλή συσκευασία	-	0,60	0,75
	Υλικά στερεά και κοίλα σε ατομική συσκευασία	-	3,00	4,00
B 134°C Πρίον	Όργανα στερεά και κοίλα σε ατομική συσκευασία	-	1,50	2,00
	Όργανα κοίλα μη συσκευασμένα	-	6,00	7,50
S 134°C Κοίλα	στερεά όργανα και τα καλώδια "B" δεν είναι συσκευασμένα	6,00	6,00	7,50
	στερεά όργανα και τα καλώδια "B" με ατομική συσκευασία	3,00	3,00	4,00
S 121°C Στερεά	στερεά όργανα και τα καλώδια "B" με ατομική συσκευασία	3,00	-	-
	στερεά όργανα και τα καλώδια "B" με ατομική συσκευασία	3,00	-	-
N 134°C Στερεά N 121°C Στερεά	στερεά όργανα και τα καλώδια "B" δεν είναι συσκευασμένα	6,00	-	-





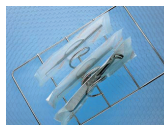

ЦИКЛЫ	ТИП НАГРУЗКИ		МАКС. КГ.		
			17S	17	22
V 134°C Универс. V 121°C Универс. V 134°C Прион	Пористые неупакованные материалы		-	1,00	1,25
	Пористые материалы в одной упаковке		-	0,75	1,00
	Пористые материалы в двойной упаковке		-	0,60	0,75
	Твердые материалы и полые в одной упаковке		-	3,00	4,00
	Твердые инструменты и полые в двойной упаковке		-	1,50	2,00
S 134°C Полые	Неупакованные полые инструменты		-	6,00	7,50
S 134°C Твердые	твердых инструментов и кабелей "В" не упакован		6,00	6,00	7,50
	твердых инструментов и кабелей "В" с индивидуальной упаковки		3,00	3,00	4,00
S 121°C Твердые S 134°C Прион	твердых инструментов и кабелей "В" с индивидуальной упаковки		3,00	-	-
N 134°C Твердые N 121°C Твердые	твердых инструментов и кабелей "В" не упакован		6,00	-	-

PT

CICLOS	TIPO DE CARGA		MÁX. KG		
			17S	17	22
B 134°C Universal B 121°C Universal B 134°C Prião	Materiais porosos não embalados		-	1,00	1,25
	Materiais porosos em embalagem individual		-	0,75	1,00
	Materiais porosos em embalagem dupla		-	0,60	0,75
	Materiais sólidos e ocos em embalagem individual		-	3,00	4,00
	Instrumentos sólidos e ocos em embalagem dupla		-	1,50	2,00
S 134°C Ocos	Instrumentos ocos não embalados		-	6,00	7,50
S 134°C Sólidos	instrumentos sólidos e cabos "B" não é embalado		6,00	6,00	7,50
	instrumentos sólidos e cabos "B", com embalagens individuais		3,00	3,00	4,00
S 121°C Sólidos S 134°C Prião	instrumentos sólidos e cabos "B", com embalagens individuais		6,00	-	-
N 134°C Sólidos N 121°C Sólidos	instrumentos sólidos e cabos "B" não é embalado		3,00	-	-

CYKLER	TYPOLOGI TILLOPP		MAX KG		
			17S	17	22
B 134°C Universal B 121°C Universal B 134°C Prion	Porösa material ej paketerade		-	1,00	1,25
	Porösa material i enkel paketering		-	0,75	1,00
	Porösa material i dubbel paketering		-	0,60	0,75
	Fasta material och kablar i enkel paketering		-	3,00	4,00
	Fasta instrument och kablar i dubbel paketering		-	1,50	2,00
S 134°C Kablar	Fasta instrument och kablar ej paketerade		-	6,00	7,50
S 134°C Solida	solida instrument och kablar "B" inte är packad		6,00	6,00	7,50
	solida instrument och kablar "B" med individuell förpackning		3,00	3,00	4,00
S 121°C Solida S 134°C Prion	solida instrument och kablar "B" med individuell förpackning		3,00	-	-
N 134°C Solida N 121°C Solida	solida instrument och kablar "B" inte är packad		6,00	-	-

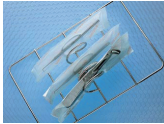
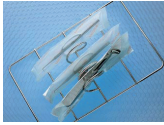
FI

JAKSOT	TÄYTTÖTYYPPI		MAX KG		
			17S	17	22
B 134°C Universaali	Pakkaamattomat huokoiset materiaalit		-	1,00	1,25
	Huokoiset materiaalit yksittäisessä pakkauksessa		-	0,75	1,00
B 121°C Universaali	Huokoiset materiaalit kaksoispakkauksessa		-	0,60	0,75
B 134°C Prioni	Kiinteät ja ontot materiaalit yksittäisessä pakkauksessa		-	3,00	4,00
	Kiinteät ja ontot instrumentit kaksoispakkauksessa		-	1,50	2,00
S 134°C Ontot	Pakkaamattomat ontot instrumentit		-	6,00	7,50
S 134°C Kiinteät	kiinteät välineet ja kaapelit "B" ei ole pakattu		6,00	6,00	7,50
	kiinteät välineet ja kaapelit "B" yksittäisten pakkausten		3,00	3,00	4,00
S 121°C Kiinteät	kiinteät välineet ja kaapelit "B" yksittäisten pakkausten		3,00	-	-
S 134°C Prioni			3,00	-	-
N 134°C Kiinteät	kiinteät välineet ja kaapelit "B" ei ole pakattu		6,00	-	-
N 121°C Kiinteät			6,00	-	-

تارود	ن حشرلا عون	مارجول يكلل ى صرقال ادعل			
		17S	17	22	
B 134°C Universal B 121°C Universal B 134°C Prion	ئىبغم ريغ ئىم اسم داوم		-	1,00	1,25
	ئىدرف قوبع يىف ئىم اسم داوم		-	0,75	1,00
	ئىچوزم قوبع يىف ئىم اسم داوم		-	0,60	0,75
	يىف تالبلكو قىبلص داوم قذح او قوبع		-	3,00	4,00
	يىف تالبلكو قىبلص تادعم ئىچوزم قوبع		-	1,50	2,00
S 134°C Hollow	ئىبغم ريغ تالبلكو تادعم		-	6,00	7,50
S 134°C Solid	تالبلكو لىقو لىصرلا "B" قىلصرلا قأبعم تىسىل		6,00	6,00	7,50
	قىلصرلا تاودالا "B" تالبلكو فىل غتلاو ئىب غتلا عم ئىدرفلا		3,00	3,00	4,00
S 121°C Solid S 134°C Prion	قىلصرلا تاودالا "B" تالبلكو فىل غتلاو ئىب غتلا عم ئىدرفلا		3,00	-	-
N 134°C Solid N 121°C Solid	تالبلكو لىقو لىصرلا "B" قىلصرلا قأبعم تىسىل		6,00	-	-

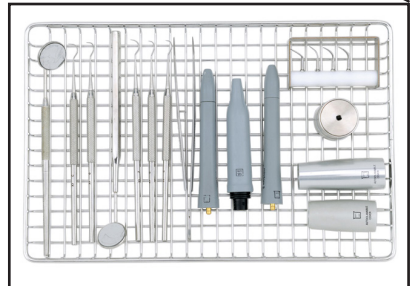
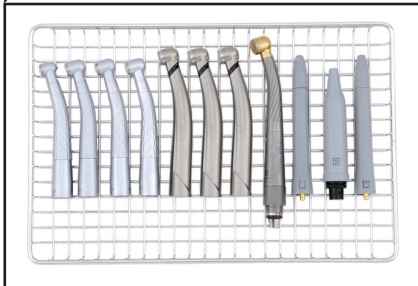
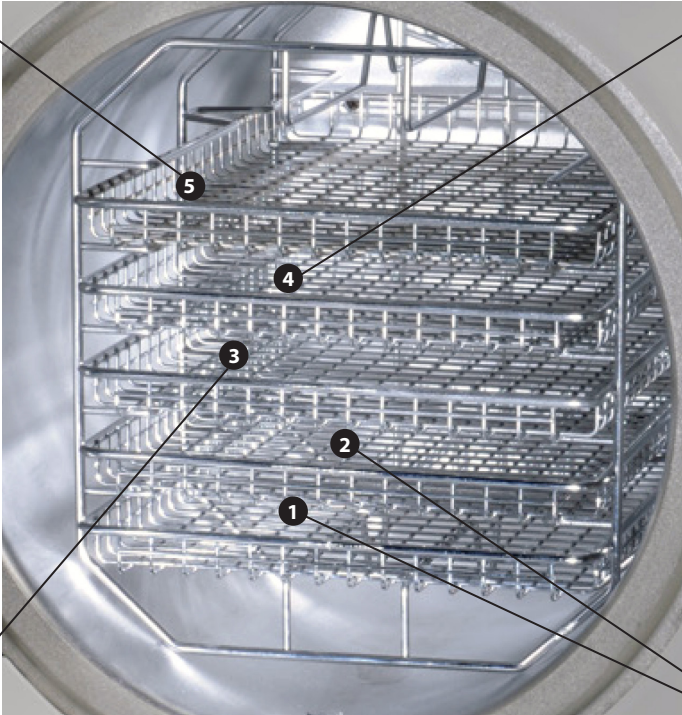

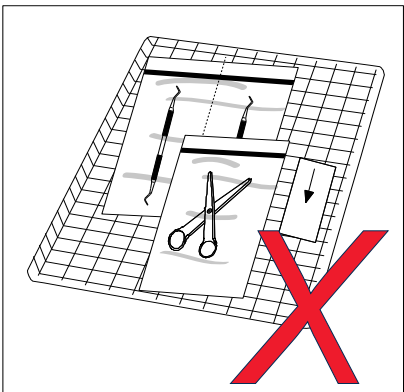
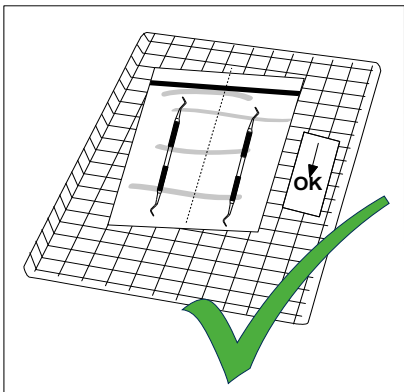
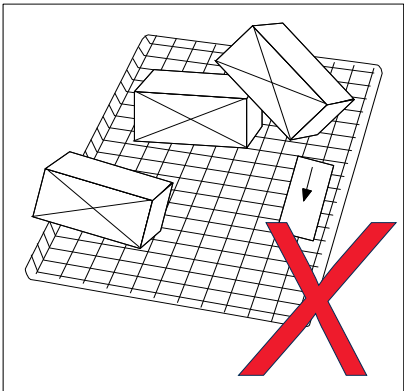
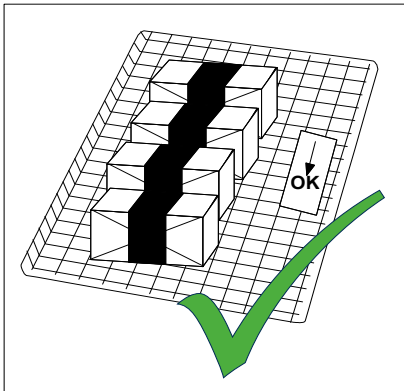
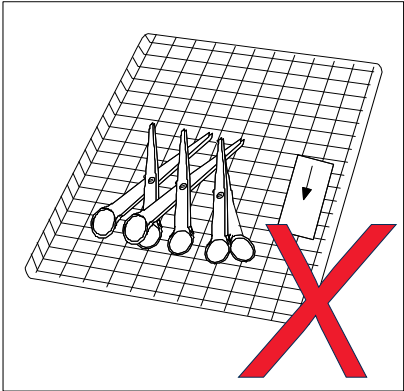
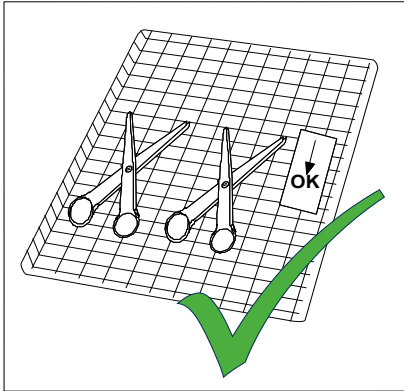

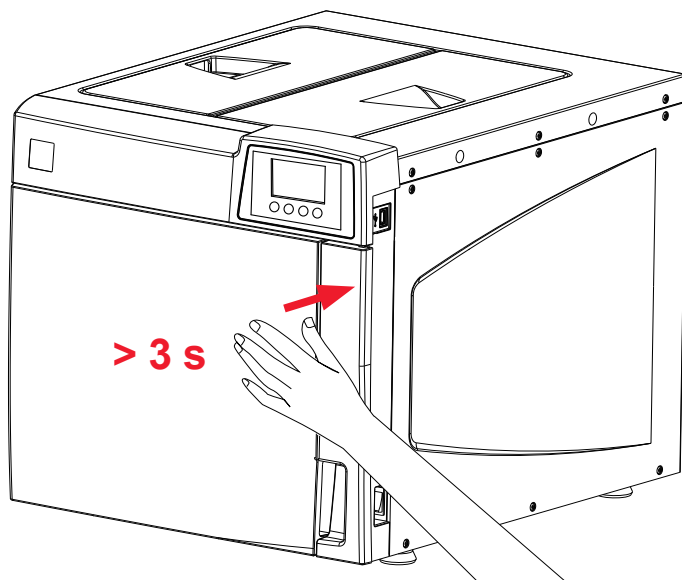
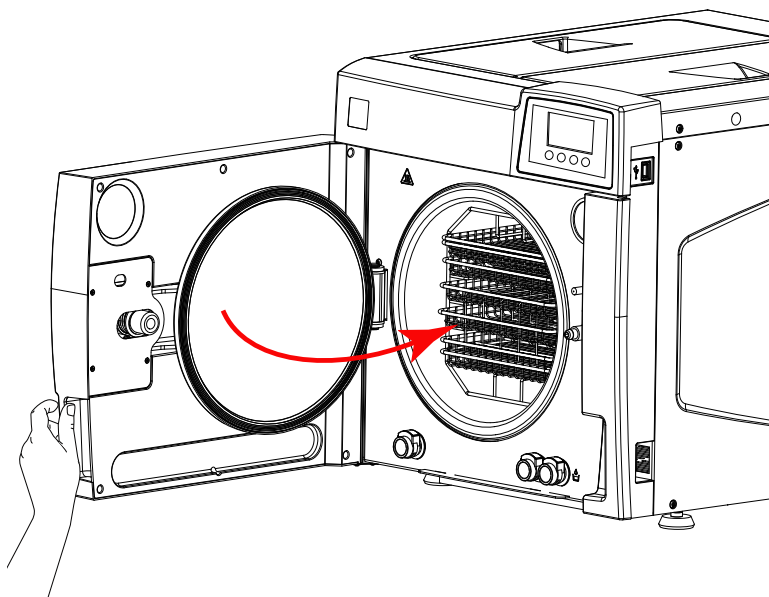

1

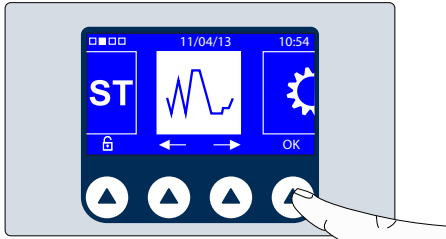

2

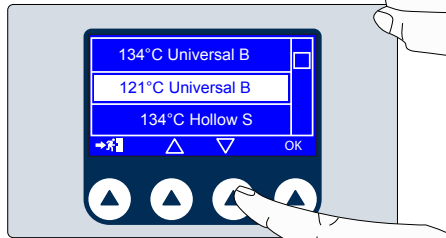

3

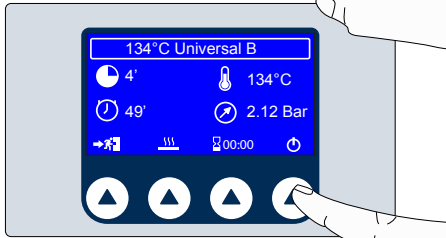

4

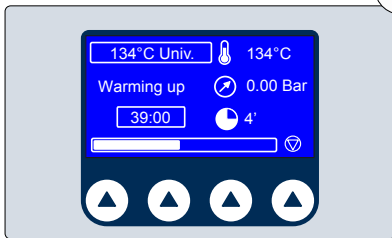

5

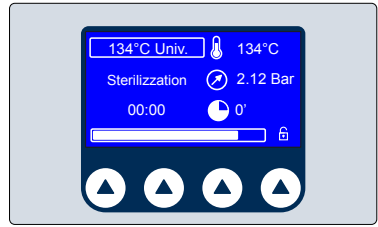

6

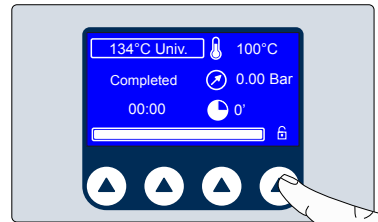

7

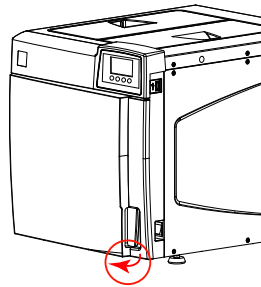

8

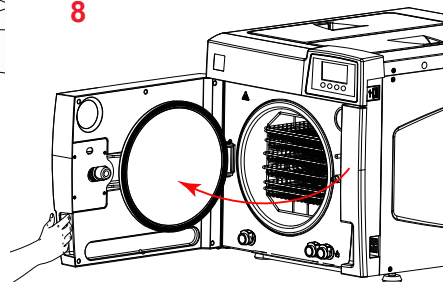

1

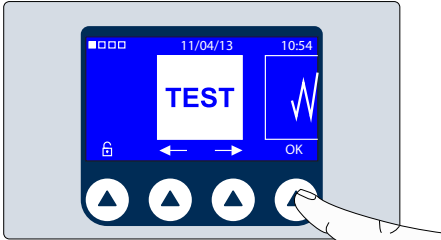

2

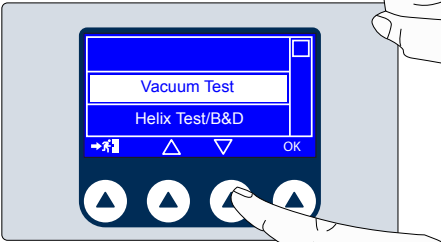

3

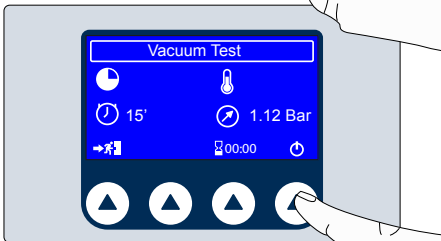

4

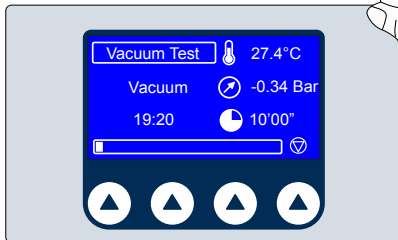

5

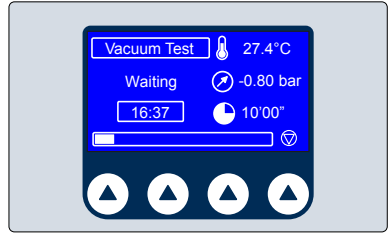

6

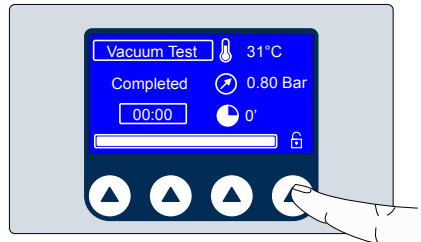

7

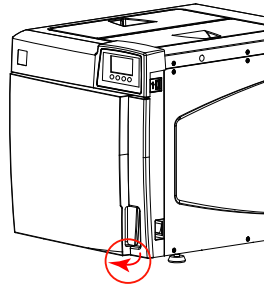

8

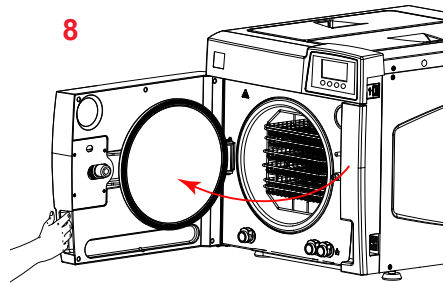

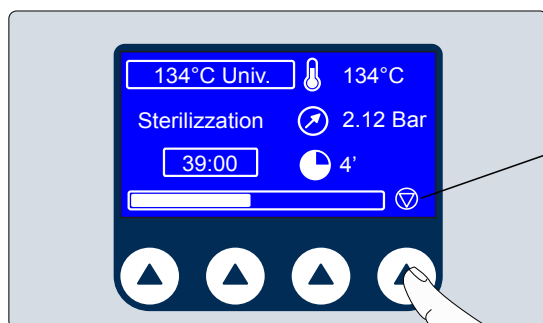
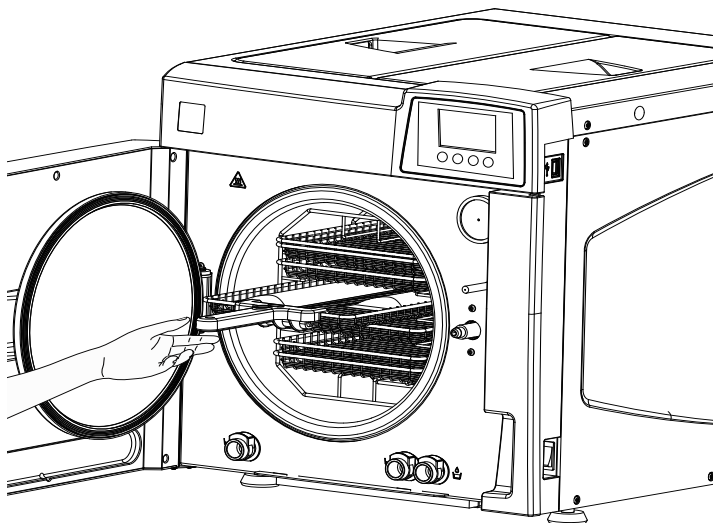

> 3 s

Stop manuale
 Manual stop
 Arrêt manuel
 Manueller Stop
 Parada manual
 Ręczne zatrzymanie
 Manuel durdurma
 Manuell stopp
 Manuální zastavení
 Manuele stop
 Εγχειρίδιο στάση
 Ручные секундомеры
 Parada manual
 Manuell stopp
 Manuaalinen pysäytys
 طخالا فقوت

IT
NOTA
Gli avvisi sono proposti all'utente con la seguente cadenza:

MESSAGGIO DI AVVISO	FREQUENZA
PULIZIA FILTRO CALDAIA	Ogni 250 cicli
LUBRIFICAZIONE BLOCCOPORTA	Ogni 250 cicli
PULIZIA FILTRO ANTIPOLVERE (no versione S)	Ogni 500 cicli
SOSTITUZIONE FILTRO BATTERIOLOGICO	Ogni 500 cicli
PULIZIA SERBATOIO ACQUA	Ogni 500 cicli
SOSTITUZIONE GUARNIZIONE CALDAIA	Ogni 1.000 cicli
REVISIONE GENERALE	Ogni 3.000 cicli

Le frequenze indicate sono calcolate su un "uso standard" dell'apparecchiatura, utilizzata correttamente e posizionata in ambiente adeguato.

Qualora si notino significative perdite di prestazione, ripetuta comparsa di allarmi o visibile degrado delle parti soggette ad usura si consiglia di provvedere alle manutenzioni previste in anticipo rispetto alle scadenze programmate nel sistema.

EN
NOTE
The warnings are displayed with the following frequency:

WARNING MESSAGE	FREQUENCY
BOILER FILTER CLEANING	Every 250 cycles
LUBRIFICATION DOOR LOCK	Every 250 cycles
DUST FILTER CLEANING (no S version)	Every 500 cycles
BACTERIOLOGICAL FILTER REPLACEMENT	Every 500 cycles
CLEANING WATER TANK	Every 500 cycles
BOILER GASKET REPLACEMENT	Every 1,000 cycles
GENERAL SERVICE	Every 3,000 cycles

The frequencies indicated have been calculated for "standard use" of the device, used correctly and positioned in a suitable environment.

Should you notice a significant loss in performance, repeated occurrence of alarms or visible degradation of the parts subject to wear, it is advisable to carry out the maintenance operations earlier than the due dates programmed in the system.

NOTE

Les avis pour l'utilisateur sont affichés avec les fréquences suivantes :

MESSAGE D'AVERTISSEMENT	FRÉQUENCE
NETTOYAGE FILTRE CHAUDIÈRE	Tous les 250 cycles
LUBRIFICATION DE VERROUILLAGE	Tous les 250 cycles
NETTOYAGE FILTRE ANTIPOUSSIÈRE <i>(pas de version S)</i>	Tous les 500 cycles
REPLACER LE FILTRE BACTÉRIOLOGIQUE	Tous les 500 cycles
NETTOYAGE DE RESERVOIR D'EAU	Tous les 500 cycles
REMPLACEMENT JOINT DE PORTE	Tous les 1 000 cycles
RÉVISION GÉNÉRALE	Tous les 3 000 cycles

Les fréquences indiquées sont calculées pour un emploi standard de l'appareil, correctement utilisé et installé dans un environnement adapté. En cas de diminutions significatives des performances, d'affichage répété d'alarmes ou d'altération évidente des parties sujettes à usure, on conseille de procéder aux opérations d'entretien prévues à l'avance par rapport aux échéances programmées dans le système.

HINWEIS

Die Hinweise an den Benutzer erscheinen mit dem folgenden Intervall:

HINWEISMELDUNG	FREQUENZ
REINIGUNG DES KESSELFILTERS	Alle 250 Zyklen
SCHMIERUNG INTERLOCK	Alle 250 Zyklen
REINIGUNG DES STAUBFILTERS <i>(keine S-Version)</i>	Alle 500 Zyklen
AUSTAUSCH DES BAKTERIOLOGISCHEN FILTERS	Alle 500 Zyklen
REINIGUNGSWASSERBEHÄLTER	Alle 500 Zyklen
AUSTAUSCH DER KESSELDICHTUNGEN	Alle 1.000 Zyklen
ALLGEMEINE ÜBERPRÜFUNG	Alle 3.000 Zyklen

Die genannten Intervalle beziehen sich auf eine "standardmäßige Verwendung" des Geräts, das ordnungsgemäß eingesetzt wird und in einer angemessenen Umgebung aufgestellt ist. Wird ein erheblicher Leistungsverlust, häufige Alarmmeldungen oder auffällige Abnutzungserscheinungen an den Verschleißteilen festgestellt, wird empfohlen, die vorgesehenen Wartungseingriffe entsprechend früher und vor den vom System vorgesehenen Wartungsintervallen durchzuführen.

ES
NOTA
Los avisos se proponen al usuario con la cadencia siguiente:

MENSAJE DE AVISO	FRECUENCIA
LIMPIEZA FILTRO CALDERA	Cada 250 ciclos
LUBRIFICACIÓN ENCLAVIMIENTO	Cada 250 ciclos
LIMPIEZA FILTRO ANTIPOLVO (ninguna versión S)	Cada 500 ciclos
SUSTITUCIÓN FILTRO BACTERIOLÓGICO	Cada 500 ciclos
LIMPIEZA DE TANQUES DE AGUA	Cada 1.000 ciclos
SUSTITUCIÓN DE LA GUARNICIÓN DE LA CALDERA	Cada 1.000 ciclos
REVISIÓN GENERAL	Cada 3.000 ciclos

Las frecuencias indicadas se calculan en base a un "uso estándar" del aparato, utilizado de manera correcta y colocado en ambiente adecuado. Si se notaran reducciones importantes en las prestaciones, las alarmas aparecieran muchas veces o se notara un degrado de las partes sometidas a desgaste, se recomienda efectuar los mantenimientos previstos con antelación respecto a las fechas programadas en el sistema.

PL
UWAGA
Zawiadomienia proponowane są użytkownikowi o następującej częstotliwości:

KOMUNIKAT OSTRZEGAJĄCY	CZĘSTOTLIWOŚĆ
CZYSZCZENIE FILTRA KOTŁA	Co 250 cykli
BLOKADA SMAROWANIE	Co 250 cykli
CZYSZCZENIE FILTRA PRZECIWPYŁOWEGO (no wersja S)	Co 500 cykli
WYMIANA FILTRA BAKTERIOLOGICZNEGO	Co 500 cykli
CZYSZCZENIE WATER TANK	Co 500 cykli
WYMIANA USZCZELKI KOTŁA	Co 1 000 cykli
OGÓLNY PRZEGLĄD	Co 3 000 cykli

Wskazane częstotliwości obliczone zostały przy "standardowym użytkowaniu" urządzenia, poprawnie obsługiwanym i umieszczonym w odpowiednim środowisku.

Jeśli zauważy się znaczący spadek wydajności, powtarzające się występowanie alarmów lub widoczne będzie zużycie części, zaleca się wcześniejsze dokonanie przewidzianej konserwacji, nie czekając na datę wyznaczoną przez system.

NOT

Uyarılar kullanıcıya aşağıda belirtilen aralıklarla iletilir:

UYARI MESAJI	FREKANSI (SIKLIĞI)
OTOKLAV FİLTRESİ TEMİZLİĞİ	Her 250 döngüde bir
YAĞLAMA İNTERLOK	Her 250 döngüde bir
TOZ FİLTRESİ TEMİZLİĞİ (Hiçbir S versiyonu)	Her 500 döngüde bir
BAKTERİ FİLTRESİ DEĞİŞTİRME	Her 500 döngüde bir
SU DEPOSU TEMİZLİK	Her 500 döngüde bir
OTOKLAV CONTASI DEĞİŞTİRME	Her 1.000 döngüde bir
GENEL REVİZYON	Her 3.000 döngüde bir

Belirtilen aralıklar cihazın uygun bir ortamda ve doğru şekilde gerçekleştirilen "standart kullanımı" üzerinden hesaplanmıştır. Cihaz performansında belirgin düşüşler görülmesi, sıkça alarm uyarısı gelmesi, aşınmaya açık parçalarda gözle görülür aşınma fark edilmesi halinde, öngörülen bakım işlemlerini sistemdeki programa göre daha sık tekrar ediniz.

MERK

Varslene presenteres for brukar i følgende rekkefølge:

VARSLINGSMELDING	FREKVENS
RENGJØRING AV FILTER VARMTVANNSBEHOLDER	Hver 250 syklus
SMØRING INTERLOCK	Hver 250 syklus
RENGJØRING AV STØVFILTER (ingen S-versjon)	Hver 500 syklus
UTSKIFTNING AV BAKTERIOLOGISK FILTER	Hver 500 syklus
RENGJØRING VANNTANK	Hver 500 syklus
UTSKIFTNING AV VARMTVANNSBEHOLDER PAKNINGER	Hver 1 000 syklus
GENERELL REVISJON	Hver 3 000 syklus

De indikerte frekvensene er beregnet for en "standard bruk" av apparatet, som brukes på korrekt måte og er plassert i et egnet miljø. Hvis betydelige tap i maskinens ytelseskraft skulle inntreffe, gjentatte alarmvarsler eller synlig forfall ved deler som er utsatte for slitasje anbefaler man å utføre forutsett vedlikehold tidligere enn programmert i systemet.

CZ
POZNÁMKA
Četnost prezentace avíza uživateli je následující:

HLÁŠENÍ S AVÍZEM	KMITOČET
ČIŠTĚNÍ FILTRU KOTLE	Každých 250 cyklů
MAZÁNÍ BLOKOVÁNÍ	Každých 250 cyklů
ČIŠTĚNÍ PRACHOVÉHO FILTRU (žádná verze S)	Každých 500 cyklů
VÝMĚNA ANTIBAKTERIÁLNÍHO FILTRU	Každých 500 cyklů
ČIŠTĚNÍ NADRŽE	Každých 500 cyklů
VÝMĚNA TĚSNĚNÍ A KOTLE	Každých 1 000 cyklů
CELKOVÁ REVIZE	Každých 3 000 cyklů

Uvedená četnost je vypočítaná ze "standardního použití" správně používaného přístroje ve vhodném prostředí.

Pokud by došlo k citelnému omezení výkonu, častým alarmům nebo viditelnému a předčasnému opotřebením součástí podléhajících opotřebením, doporučuje se provádět údržbu s vyšší četností vzhledem k údržbě systémem naprogramované.

NL
NOTA
De berichten worden aan de gebruiker voorgesteld met de volgende frequentie:

WAARSCHUWINGSBERICHT	FREQUENTIE
SCHOONMAAK FILTER BOILER	Alle 250 cycli
SMERING INTERLOCK	Alle 250 cycli
SCHOONMAAK STOFFILTER (geen S-versie)	Alle 500 cycli
VERVANGING BACTERIOLOGISCHE FILTER	Alle 500 cycli
REINIGEN WATERTANK	Alle 500 cycli
VERVANGING PAKKINGEN BOILER	Alle 1.000 cycli
ALGEMEEN NAZICHT	Alle 3.000 cycli

De aangeduide frequenties zijn berekend op een "standaard gebruik" van de apparatuur, correct gebruikt en op een adequate plaats geïnstalleerd. Ingeval men opmerkelijke verliezen van prestaties, een herhaaldelijk verschijnen van alarmen of een zichtbare verslechtering van de onderdelen onderhevig aan slijtage vaststelt, raadt men aan eerder over te gaan tot de geplande ingrepen van onderhoud in vergelijking met de geprogrammeerde ingrepen van het systeem.

ΣΗΜΕΙΩΣΗ

Οι ειδοποιήσεις προτείνονται στο χρήστη με την ακόλουθη συχνότητα:

ΜΗΝΥΜΑ ΕΙΔΟΠΟΙΗΣΗΣ	ΣΥΧΝΟΤΗΤΑ
ΚΑΘΑΡΙΣΜΟΣ ΦΙΛΤΡΟΥ ΛΕΒΗΤΑ	Κάθε 250 κύκλους
LUBRICATION INTERLOCK	Κάθε 250 κύκλους
ΚΑΘΑΡΙΣΜΟΣ ΦΙΛΤΡΟΥ ΣΥΓΚΡΑΤΗΣΗΣ ΣΚΟΝΗΣ (καμία έκδοση S)	Κάθε 500 κύκλους
ΑΝΤΙΚΑΤΑΣΤΑΣΗ ΒΑΚΤΗΡΙΟΛΟΓΙΚΟΥ ΦΙΛΤΡΟΥ	Κάθε 500 κύκλους
ΚΑΘΑΡΙΣΜΟΙ ΔΕΞΑΜΕΝΩΝ ΝΕΡΟΥ	Κάθε 500 κύκλους
ΑΝΤΙΚΑΤΑΣΤΑΣΗ ΤΣΙΜΟΥΧΑΣ ΛΕΒΗΤΑ	Κάθε 1.000 κύκλους
ΓΕΝΙΚΟΣ ΕΛΕΓΧΟΣ	Κάθε 3.000 κύκλους

Οι αναφερόμενες συχνότητες υπολογίζονται σε μια “σπάνια χρήση” της συσκευής, χρησιμοποιούμενης σωστά και τοποθετημένης σε κατάλληλο περιβάλλον. Αν παρατηρηθούν σημαντικές απώλειες επιδόσεων, επαναλαμβανόμενη εμφάνιση συναγερμών ή ορατή παρακμή των μερών που υπόκεινται σε φθορά, συστήνεται να μεριμνήσετε για τις προβλεπόμενες συντηρήσεις νωρίτερα σε σχέση με τις προγραμματισμένες ημερομηνίες του σύστημα.

ПРИМЕЧАНИЕ

Сообщения представляются пользователю в следующей последовательности:

ΠΡΕΔΥΠΕΡΕΧΟΜΕΝΟ ΣΟΟΒΜΕΝΟ	ΧΑΡΑΤΗΡΑ
ΟΧΙΣΤΑ ΦΙΛΤΡΑ ΚΟΤΑ	Καθες 250 κύκλους
ΣΜΑΖΑ ΙΝΤΕΡΛΟΚ	Καθες 250 κύκλους
ΟΧΙΣΤΑ ΠΡΟΤΙΒΟΠΥΛΝΟΦ ΦΙΛΤΡΑ (Нет версии S)	Καθες 500 κύκλους
ΖΑΜΕΝΑ ΒΑΚΤΗΡΙΟΛΟΓΙΧΕΣΟΦ ΦΙΛΤΡΑ	Καθες 500 κύκλους
Προμυβονχού νερού	Καθες 500 κύκλους
ΖΑΜΕΝΑ ΠΡΟΚΛΑΔΚΙ ΚΟΤΑ	Καθες 1 000 κύκλους
ΟΒΧΑΑ ΡΕΒΙΖΙΑ	Καθες 3 000 κύκλους

Указанная частота относится к “стандартному применению” оборудования, используемого правильно и устанавливаемого в соответствующем помещении.

При значительном понижении рабочих характеристик, частой подачи аварийных сигналов или видимом ухудшении состояния подверженных износу деталей рекомендуется проводить техосмотр раньше сроков, запрограммированных в системе.

PT
NOTA
Os avisos são propostos ao utilizador com a seguinte frequência:

MENSAGEM DE AVISO	FREQUÊNCIA
LIMPEZA DO FILTRO DA CALDEIRA	Todos os 250 ciclos
LUBRICATION INTERLOCK	Todos os 250 ciclos
LIMPEZA DO FILTRO ANTIPÓ (nenhuma versão S)	Todos os 500 ciclos
SUBSTITUIÇÃO DO FILTRO BACTERIOLÓGICO	Todos os 500 ciclos
TANQUE DE ÁGUA DE LIMPEZA	Todos os 500 ciclos
SUBSTITUIÇÃO DE VEDANTES E CALDEIRA	Todos os 1.000 ciclos
REVISÃO GERAL	Todos os 3.000 ciclos

As frequências indicadas são calculadas com base num “uso padrão” do equipamento, utilizado corretamente e instalado em ambiente adequado. Se o utilizador notar reduções significativas de desempenho, aparecimento repetido de alarmes ou degradação visível de partes sujeitas a desgaste, aconselha-se a proceder às operações de manutenção antecipadamente em relação aos intervalos programados no sistema.

SV
OBSERVERA
Varningarna föreslås till användaren med följande frekvens:

VARNINGSMEDDELANDE	FREKVENS
RENGÖRING FILTER VÄRMEPANNA	Var 250 cykel
LUBRICATION INTERLOCK	Var 250 cykel
RENGÖRING DAMMFILTER (Nej S version)	Var 500 cykel
BYTE BAKTERIEFILTER	Var 500 cykel
VATTEN tankrengöring	Var 500 cykel
BYTE PACKNING VÄRMEPANNA	Var 1 000 cykel
ALLMÄN ÖVERSYN	Var 3 000 cykel

Angivna frekvenser är beräknade på en “vanlig användning” av apparaten, använd på ett korrekt sätt och placerad i rätt miljö.

Om du märker betydande prestanda förluster, upprepade larm eller uppenbar försämring av delar som utsätts för slitage, är det lämpligt att utföra planerat underhåll i förtid i förhållande till de som systemet planerat.

ACCESSORI - ACCESSORIES - ACCESSOIRES - ZUBEHÖR
 ACCESORIOS - WYPOSAŻENIE - AKSESUARLAR - TILBEHØR
 PŘÍSLUŠENSTVÍ - TOEBEHÖREN - ΑΞΕΣΟΥΑΡ - ΑΚΚΕΣΟΥΑΡΥ
 ACESSÓRIOS - TILLBEHÖR - LISÄVARUSTEET - تاق حل مل

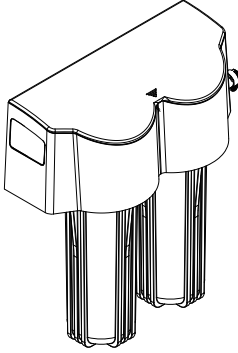

PURE 100

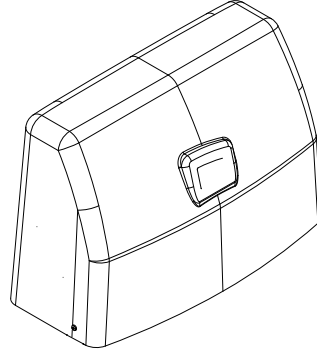

PURE 500

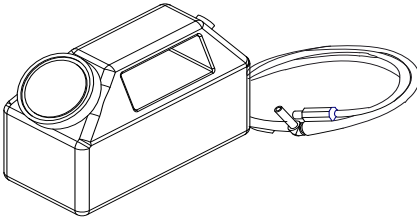

CARICO FRONTALE
 FRONT FILLING
 CHARGEMENT
 BEFÜLLUNG
 CARGA FRONTAL
 ZAŁADUNEK
 ÖNDEN DOLDURMA
 FRONTAL LASTING
 ČELNÍ NAPOUŠTĚNÍ
 FRONTALE TOEVOER
 ΠΡΟΣΘΙΑ
 ПЕРЕДНИЙ НАБОР
 CARGA FRONTAL
 FRONTLADDNING
 TÄYTTÖ EDESTÄ

ي م ا ل ا مل

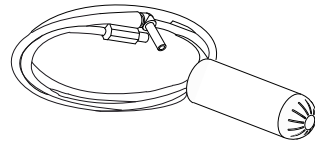

CARICO AUTOMATICO
 AUTOMATIC FILLING
 CHARGEMENT AUTOMATIQUE
 AUTOMATISCHE BEFÜLLUNG
 CARGA AUTOMÁTICA
 AUTOMATYCZNY ZAŁADUNEK
 OTOMATİK DOLDURMA
 AUTOMATISK LASTING
 AUTOMATICKÉ NAPOUŠTĚNÍ
 AUTOMATISCHE TOEVOER
 ΑΥΤΟΜΑΤΗ ΤΡΟΦΟΔΟΣΙΑ
 АВТОМАТИЧЕСКИЙ НАБОР
 CARREGAMENTO AUTOMÁTICO
 AUTOMATISK LADDNING
 AUTOMAATTINEN TÄYTTÖ

ي ك ي تاموت وال مل

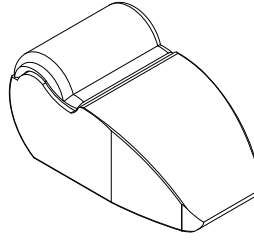

STAMPANTE
PRINTER
IMPRIMANTE
DRUCKER
IMPRESORA
DRUKARKA
YAZICI
SKRIVER
TISKÁRNA
PRINTER
ΕΚΤΥΠΩΤΗΣ
ΠΡΙΝΤΕΡ
IMPRESSORA
SKRIVARE
TULOSTIN

دعاب اطال